

## Operation Manual

# R-Series V POWERLINK

Magnetostrictive Linear Position Sensors

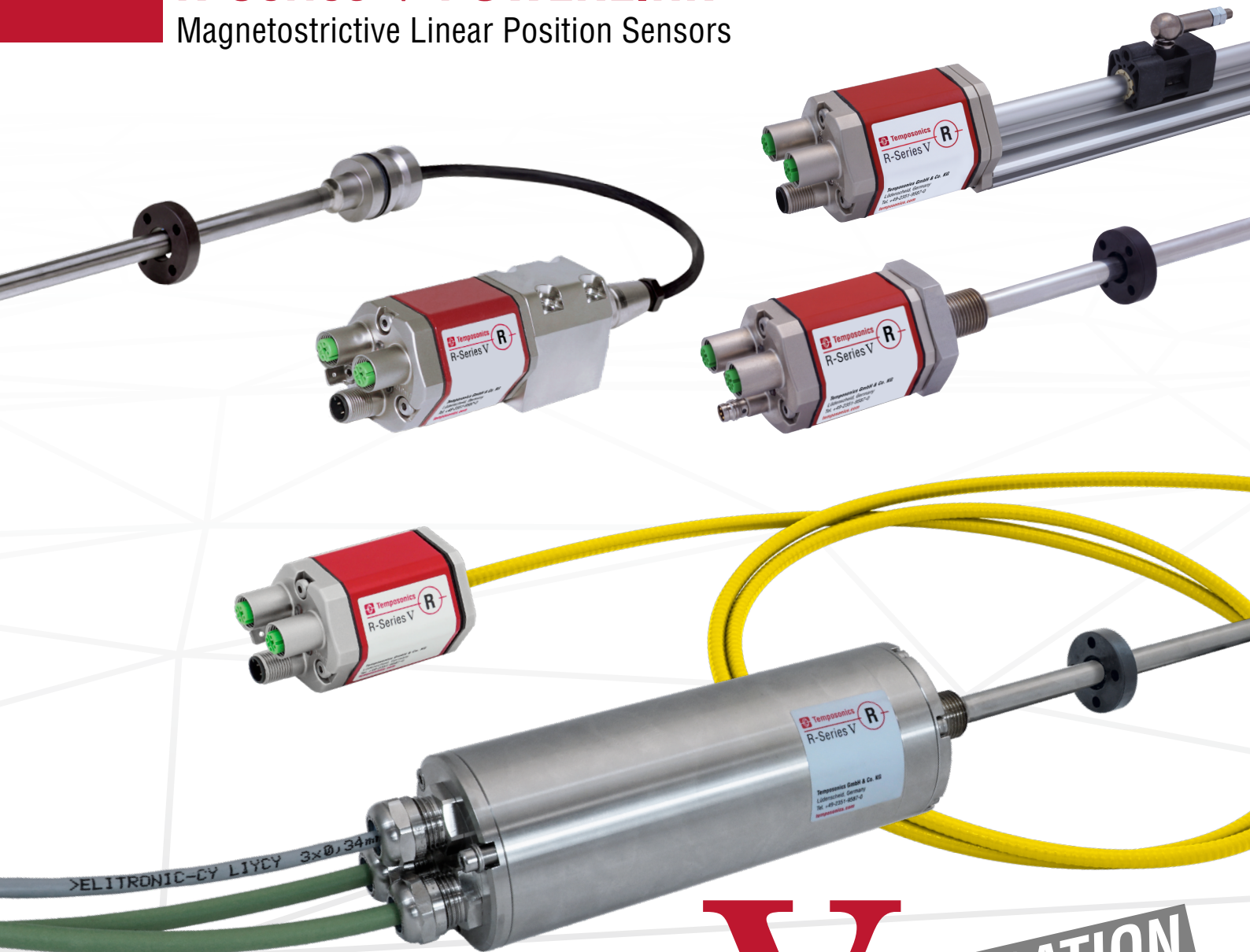

**V**  
THE NEW GENERATION

## Table of contents

<b>1. Introduction</b>	<b>4</b>
1.1 Purpose and use of this manual	4
1.2 Used symbols and warnings	4
<b>2. Safety instructions</b>	<b>4</b>
2.1 Intended use	4
2.2 Foreseeable misuse	4
2.3 Installation, commissioning and operation	5
2.4 Safety instructions for use in explosion-hazardous areas	5
2.5 Warranty	5
2.6 Return	5
<b>3. Identification</b>	<b>6</b>
3.1 Order code of Temposonics® RP5	6
3.2 Order code of Temposonics® RH5	7
3.3 Order code of Temposonics® RM5	8
3.4 Order code of Temposonics® RF5	9
3.5 Order code of Temposonics® RFV	10
3.6 Order code of Temposonics® RDV	11
3.7 Nameplate	12
3.8 Approvals	12
3.9 Scope of delivery	12
<b>4. Product description and commissioning</b>	<b>13</b>
4.1 Functionality and system design	13
4.2 Installation and design of Temposonics® RP5	14
4.3 Installation and design of Temposonics® RH5	15
4.4 Installation and design of Temposonics® RM5	18
4.5 Installation and design of Temposonics® RF5	20
4.6 Installation and design of Temposonics® RFV	24
4.7 Installation and design of Temposonics® RDV	28
4.8 Magnet installation	33
4.9 Alignment of the magnet with the option “Internal linearization”	38
4.10 Replacement of base unit	40
4.11 Electrical connection	43
4.12 Frequently ordered accessories for Temposonics® RP5	46
4.13 Frequently ordered accessories for Temposonics® RH5	47
4.14 Frequently ordered accessories for Temposonics® RM5	48
4.15 Frequently ordered accessories for Temposonics® RF5	49
4.16 Frequently ordered accessories for Temposonics® RFV	50
4.17 Frequently ordered accessories for Temposonics® RDV	52
4.18 Frequently ordered accessories for POWERLINK output	54
<b>5. Commissioning</b>	<b>56</b>
5.1 Initial start-up	56
5.2 LED status	56
5.3 Topologies and hubs	57
<b>6. Node ID configuration of R-Series V POWERLINK</b>	<b>58</b>
6.1 Setting the node ID via TempoLink® smart assistant	58
6.2 Setting the node ID via “Automation Studio”	61
<b>7. Integration of R-Series V POWERLINK in the control system</b>	<b>65</b>
7.1 Importing R-Series V POWERLINK sensor into the project tool	65
7.2 Communication segment	68
<b>8. Maintenance and troubleshooting</b>	<b>72</b>
8.1 Error conditions, troubleshooting	72
8.2 Maintenance	72
8.3 Repair	72
8.4 List of spare parts	72
8.5 Transport and storage	72

<b>9. Removal from service/dismantling</b> .....	<b>72</b>
<b>10. Technical data</b> .....	<b>73</b>
10.1 Technical data of Temposonics® RP5.....	73
10.2 Technical data of Temposonics® RH5 .....	75
10.3 Technical data of Temposonics® RM5.....	77
10.4 Technical data of Temposonics® RF5.....	78
10.5 Technical data of Temposonics® RFV.....	79
10.6 Technical data of Temposonics® RDV .....	80
<b>11. Appendix I – Safety declaration</b> .....	<b>82</b>
<b>12. Appendix II – Cylinder port details</b> .....	<b>83</b>
<b>13. Glossary</b> .....	<b>84</b>

## 1. Introduction

### 1.1 Purpose and use of this manual

Before starting the operation of Temposonics® position sensors, read this documentation thoroughly and follow the safety information. Keep this manual for future reference!

The content of this technical documentation and of its appendices is intended to provide information on mounting, installation and commissioning by qualified automation personnel <sup>1</sup> or instructed service technicians who are familiar with the project planning and dealing with Temposonics® sensors.

### 1.2 Used symbols and warnings

Warnings are intended for your personal safety and for avoidance of damage to the described product or connected devices. In this documentation, safety information and warnings to avoid danger that might affect the life and health of operating or service personnel or cause material damage are highlighted by the pictogram defined below.

Symbol	Meaning
<b>NOTICE</b>	This symbol is used to point to situations that may lead to material damage, but not to personal injury.

## 2. Safety instructions

### 2.1 Intended use

This product may be used only for the applications defined under item 1 and only in conjunction with the third-party devices and components recommended or approved by Temposonics. As a prerequisite of proper and safe operation the product requires correct transport, storage, mounting and commissioning and must be operated with utmost care.

- The sensor systems of all Temposonics® series are intended exclusively for measurement tasks encountered in industrial, commercial and laboratory applications. The sensors are considered as system accessories and must be connected to suitable evaluation electronics, e.g. a PLC, IPC, indicator or other electronic control unit.

### 2.2 Foreseeable misuse

Foreseeable misuse	Consequence
Wrong sensor connection	The sensor will not work properly or can be damaged
Operate the sensor out of the operating temperature range	No signal output – the sensor can be damaged
Power supply is out of the defined range	Signal output is wrong/ no signal output/ the sensor will be damaged
Position measurement is influenced by an external magnetic field	Signal output is wrong
Cables are damaged	Short circuit – the sensor can be damaged/sensor does not respond
Spacers are missing/ installed in a wrong order	Error in position measurement
Wrong connection of ground/shield	Signal output is disturbed – the electronics can be damaged
Use of a magnet that is not specified by Temposonics	Error in position measurement

**Do not alter the sensor subsequently.**

→ The sensor might be damaged.

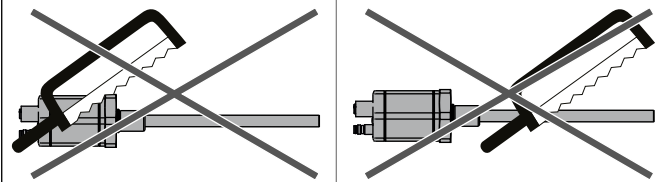

**Do not step on the sensor.**

→ The sensor might be damaged.

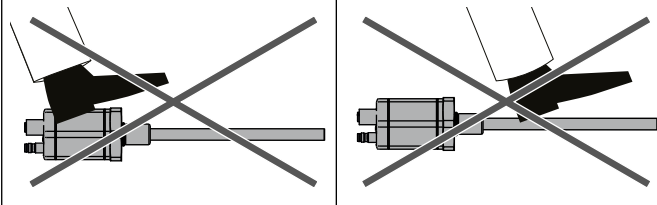

<sup>1/</sup> The term “qualified technical personnel” characterizes persons who:

- are familiar with the safety concepts of automation technology applicable to the particular project

- are competent in the field of electromagnetic compatibility (EMC)
- have received adequate training for commissioning and service operations
- are familiar with the operation of the device and know the information required for correct operation provided in the product documentation

### 2.3 Installation, commissioning and operation

The position sensors must be used only in technically safe conditions. To maintain this condition and to ensure safe operation, installation, connection and service, work may be performed only by qualified technical personnel. If danger of injury to persons or of damage to operating equipment is caused by sensor failure or malfunction, additional safety measures such as plausibility checks, limit switches, EMERGENCY STOP systems, protective devices etc. are required. In the event of trouble, shut down the sensor and protect it against accidental operation.

#### Safety instructions for commissioning

To maintain the sensor's operability, it is mandatory to follow the instructions given below.

1. Protect the sensor against mechanical damage during installation and operation.
2. Do not open or dismantle the sensor.
3. Connect the sensor very carefully and pay attention to the polarity of connections and power supply.
4. Use only approved power supplies.
5. Ensure the sensor is operating within the defined limits for supply voltage, environmental conditions, etc.
6. Check the function of the sensor regularly and provide documentation of the checks.
7. Before applying power, ensure that nobody's safety is jeopardized by starting machines.

### 2.4 Safety instructions for use in explosion-hazardous areas

The sensor is not suitable for operation in explosion-hazardous areas.

### 2.5 Warranty

Temposonics grants a warranty period<sup>2</sup> for the position sensors and supplied accessories relating to material defects and faults that occur despite correct use in accordance with the intended application. The Temposonics obligation is limited to repair or replacement of any defective part of the unit. No warranty can be provided for defects that are due to improper use or above average stress of the product as well as for wear parts. Under no circumstances will Temposonics accept liability in the event of offense against the warranty rules, no matter if these have been assured or expected, even in case of fault or negligence of the company.

Temposonics explicitly excludes any further warranties. Neither the company's representatives, agents, dealers nor employees are authorized to increase or change the scope of warranty.

### 2.6 Return

For diagnostic purposes, the sensor can be returned to Temposonics or a repair facility explicitly authorized by Temposonics. Any shipment cost is the responsibility of the sender<sup>2</sup>. For a corresponding form, see chapter "11. Appendix I – Safety declaration" on page 82.

#### NOTICE

When returning sensors, place protective caps on male and female connectors of the sensor. For pigtail cables, place the cable ends in a static shielding bag for electrostatic discharge (ESD) protection. Fill the outer packaging around the sensor completely to prevent damage during transport.

<sup>2/</sup> See also applicable Temposonics terms of sales and delivery on:  
[www.temposonics.com](http://www.temposonics.com)

### 3. Identification

#### 3.1 Order code of Temposonics® RP5

1	2	3	4	5	6	7	8	9	10	11	12	13	14	15	16	17	18	19	20	
R	P	5										D	5		1	U	3		1	
a			b	c	d						e		f			g	h			

a	Sensor model
R P 5	Profile

b	Design
G	Magnet slider backlash free (part no. 253 421), suitable for internal linearization
L	Block magnet L (part no. 403 448)
M	U-magnet OD33 (part no. 251 416-2), suitable for internal linearization
N	Magnet slider longer ball-jointed arm (part no. 252 183), suitable for internal linearization
O	No position magnet
S	Magnet slider joint at top (part no. 252 182), suitable for internal linearization
V	Magnet slider joint at front (part no. 252 184), suitable for internal linearization

c	Mechanical options
A	Standard
V	Fluorelastomer seals for the sensor electronics housing

d	Stroke length
X X X X M	0025...6350 mm
Standard stroke length (mm)	Ordering steps
25... 500 mm	25 mm
500...2500 mm	50 mm
2500...5000 mm	100 mm
5000...6350 mm	250 mm
X X X X U	001.0...250.0 in.
Standard stroke length (in.)	Ordering steps
1... 20 in.	1.0 in.
20...100 in.	2.0 in.
100...200 in.	4.0 in.
200...250 in.	10.0 in.

Non-standard stroke lengths are available; must be encoded in 5 mm/0.1 in. increments.

e	Number of magnets
X X	01...30 position(s) (1...30 magnet(s))

f	Connection type
D 5 6	2 × M12 female connectors (D-coded), 1 × M8 male connector
D 5 8	2 × M12 female connectors (D-coded), 1 × M12 male connector (A-coded)

g	System
1	Standard

h	Output
U 3 0 1	POWERLINK, position and velocity (1...30 magnet(s))
U 3 1 1	POWERLINK, position and velocity, internal linearization (1...30 magnet(s))

#### NOTICE

- For the RP5, the magnet selected in **b** "Design" is included in the scope of delivery. Specify the number of magnets for your application. For multi-position measurements with more than one magnet order the other magnets separately.
- The number of magnets is limited by the stroke length. The minimum allowed distance between magnets (i.e. front face of one to the front face of the next one) is 75 mm (3 in.).
- Use magnets of the same type for multi-position measurement.
- If the option for internal linearization (U311) in **h** "Output" is chosen, select a suitable magnet.

### 3.2 Order code of Temposonics® RH5

1	2	3	4	5	6	7	8	9	10	11	12	13	14	15	16	17	18	19	20
R	H	5										D	5		1	U	3		1
a			b	c	d						e	f			g	h			

a	Sensor model
R H 5	Rod

b	Design
B	Base unit (only for replacement)
J	Threaded flange M22×1.5-6g (rod Ø 12.7 mm), stroke length: 25...5900 mm (1...232 in.)
M	Threaded flange M18×1.5-6g (standard)
S	Threaded flange ¾"-16 UNF-3A (standard)
T	Threaded flange ¾"-16 UNF-3A (with raised-face)

c	Mechanical options
A	Standard
B	Bushing on rod end (only for design »M«, »S« & »T«)
F	Flexible sensing element (only for design »B«, »M«, »S« & »T«)
M	Thread M4 at rod end (only for design »M«, »S« & »T«)
V	Fluorelastomer seals for the sensor electronics housing

d	Stroke length	
X X X X M	0025...7620 mm	
Standard stroke length (mm)		Ordering steps
25... 500 mm		5 mm
500... 750 mm		10 mm
750...1000 mm		25 mm
1000...2500 mm		50 mm
2500...5000 mm		100 mm
5000...7620 mm		250 mm
X X X X U	001.0...300.0 in.	
Standard stroke length (in.)		Ordering steps
1... 20 in.		0.2 in.
20... 30 in.		0.4 in.
30... 40 in.		1.0 in.
40...100 in.		2.0 in.
100...200 in.		4.0 in.
200...300 in.		10.0 in.
Non-standard stroke lengths are available; must be encoded in 5 mm/0.1 in. increments.		

e	Number of magnets
X X	01...30 position(s) (1...30 magnet(s))

f	Connection type
D 5 6	2 × M12 female connectors (D-coded), 1 × M8 male connector

D 5 8	2 × M12 female connectors (D-coded), 1 × M12 male connector (A-coded)
-------	---

g	System
1	Standard

h	Output
U 3 0 1	POWERLINK, position and velocity (1...30 magnet(s))
U 3 1 1	POWERLINK, position and velocity, internal linearization (1...30 magnet(s))

#### NOTICE

- Specify the number of magnets for your application and order the magnets separately.
- The number of magnets is limited by the stroke length. The minimum allowed distance between magnets (i.e. front face of one to the front face of the next one) is 75 mm (3 in.).
- Use magnets of the same type for multi-position measurement.
- If the option for internal linearization (U311) in **h** "Output" is chosen, select a suitable magnet.
- The internal linearization (U311) in **h** "Output" is not available with the flexible sensing element **F** in **c** "Mechanical options".

### 3.3 Order code of Temposonics® RM5

1	2	3	4	5	6	7	8	9	10	11	12	13	14	15	16	17	18	19	20
R	M	5		A											1	U	3		1
a			b	c	d					e	f			g	h				

<b>a</b>	<b>Sensor model</b>
R M 5	Super shield housing

<b>b</b>	<b>Design</b>
B	Base unit (only for replacement/only with connection type D58)
M	Threaded flange M18×1.5-6g (standard)
S	Threaded flange ¾"-16 UNF-3A (standard)

<b>c</b>	<b>Mechanical options</b>
A	Standard

<b>d</b>	<b>Stroke length</b>
X X X X M	0025...7615 mm

Standard stroke length (mm)	Ordering steps
25... 500 mm	5 mm
500... 750 mm	10 mm
750...1000 mm	25 mm
1000...2500 mm	50 mm
2500...5000 mm	100 mm
5000...7615 mm	250 mm

X X X X U	001.0...299.8 in.
-----------	-------------------

Standard stroke length (in.)	Ordering steps
1... 20 in.	0.2 in.
20... 30 in.	0.4 in.
30... 40 in.	1.0 in.
40...100 in.	2.0 in.
100...200 in.	4.0 in.
200...299.8 in.	10.0 in.

Non-standard stroke lengths are available; must be encoded in 5 mm/0.1 in. increments.

<b>e</b>	<b>Number of magnets</b>
X X	01...30 position(s) (1...30 magnet(s))

<b>f</b>	<b>Connection type</b>
D 5 8	2 × M12 female connectors (D-coded), 1 × M12 male connector (A-coded) (only for RM5-B)
M X X	2 × XX m/ft. PUR cable (part no. 530 125) for data lines with M12 female connector (part no. 370 830) and 1 × XX m/ft. PVC cable (part no. 530 108) for power supply M01...M10 (1...10 m/1...33 ft.) See "Frequently ordered accessories" for cable & connector specifications
Encode in meters if using metric stroke length Encode in feet if using US customary stroke length	

<b>g</b>	<b>System</b>
1	Standard

<b>h</b>	<b>Output</b>
U 3 0 1	POWERLINK, position and velocity (1...30 magnet(s))
U 3 1 1	POWERLINK, position and velocity, internal linearization (1...30 magnet(s))

#### NOTICE

- Specify the number of magnets for your application and order the magnets separately.
- The number of magnets is limited by the stroke length. The minimum allowed distance between magnets (i.e. front face of one to the front face of the next one) is 75 mm (3 in.).
- Use magnets of the same type for multi-position measurement.
- If the option for internal linearization (U311) in **h** "Output" is chosen, select a suitable magnet.

### 3.4 Order code of Temposonics® RF5

1	2	3	4	5	6	7	8	9	10	11	12	13	14	15	16	17	18	19	20
R	F	5										D	5		1	U	3	0	1
a			b	d						e	f			g	h				

a	Sensor model		
R	F	5	Improved flexible rod

b	Design		
B	Base unit (without flange & rod assembly)		

Section **c** is intentionally omitted.

d	Stroke length					
X	X	X	X	X	M	00150...20000 mm
Stroke length (mm)		Ordering steps				
150... 1000 mm		50 mm				
1000... 5000 mm		100 mm				
5000... 10000 mm		250 mm				
10000... 15000 mm		500 mm				
15000... 20000 mm		1000 mm				
X	X	X	X	X	U	0006.0...0787.0 in.
Stroke length (in.)		Ordering steps				
6... 40 in.		2 in.				
40... 197 in.		4 in.				
197... 394 in.		10 in.				
394... 591 in.		20 in.				
591... 787 in.		40 in.				
Non standard stroke lengths are available; must be encoded in 5 mm/0.1 in. increments						

e	Number of magnets		
X	X	01...30 position(s) (1...30 magnet(s))	

f	Connection type		
D	5	6	2 × M12 female connectors (D-coded), 1 × M8 male connector

D	5	8	2 × M12 female connectors (D-coded), 1 × M12 male connector (A-coded)
---	---	---	--

g	System		
1	Standard		

h	Output			
U	3	0	1	POWERLINK, position and velocity (1...30 magnet(s))

#### NOTICE

- Specify the number of magnets for your application and order the magnets separately.
- The number of magnets is limited by the stroke length. The minimum allowed distance between magnets (i.e. front face of one to the front face of the next one) is 75 mm (3 in.).
- Use magnets of the same type for multi-position measurement.
- The sensor is without rod assembly. Always insert the flexible sensor rod in a support pipe (e.g. sensor rod HD/HL/HP or HFP profile).

### 3.5 Order code of Temposonics® RFV

1	2	3	4	5	6	7	8	9	10	11	12	13	14	15	16	17	18	19	20
R	F	V										D	5		1	U	3	0	1
a			b	d						e		f			g	h			

<b>a</b>	<b>Sensor model</b>		
R	F	V	Flexible rod

<b>b</b>	<b>Design</b>
B	Base unit (without flange & rod assembly)
M	Threaded flange M18×1.5-6g (without rod assembly)
S	Threaded flange ¾"-16 UNF-3A (without rod assembly)

Section **c** is intentionally omitted.

<b>d</b>	<b>Stroke length</b>					
X	X	X	X	X	M	00150...20000 mm

Stroke length (mm)	Ordering steps
150... 1000 mm	50 mm
1000... 5000 mm	100 mm
5000... 10000 mm	250 mm
10000... 15000 mm	500 mm
15000... 20000 mm	1000 mm

X	X	X	X	X	U	0006.0...0787.0 in.
---	---	---	---	---	---	---------------------

Stroke length (in.)	Ordering steps
6... 40 in.	2 in.
40... 197 in.	4 in.
197... 394 in.	10 in.
394... 591 in.	20 in.
591... 787 in.	40 in.

Non standard stroke lengths are available;  
must be encoded in 5 mm/0.1 in. increments

<b>e</b>	<b>Number of magnets</b>	
X	X	01...30 position(s) (1...30 magnet(s))

<b>f</b>	<b>Connection type</b>		
D	5	6	2×M12 female connectors (D-coded), 1×M8 male connector
D	5	8	2×M12 female connectors (D-coded), 1×M12 male connector (A-coded)

<b>g</b>	<b>System</b>
1	Standard

<b>h</b>	<b>Output</b>			
U	3	0	1	POWERLINK, position and velocity (1...30 magnet(s))

#### NOTICE

- Specify the number of magnets for your application and order the magnets separately.
- The number of magnets is limited by the stroke length. The minimum allowed distance between magnets (i.e. front face of one to the front face of the next one) is 75 mm (3 in.).
- Use magnets of the same type for multi-position measurement.
- RFV-B/M/S are without rod assembly. Always insert the flexible sensor rod in a support pipe (e.g. sensor rod HD/HL/HP or HFP profile).

### 3.6 Order code of Temposonics® RDV

1	2	3	4	5	6	7	8	9	10	11	12	13	14	15	16	17	18	19	20	
R	D	V										D	5		1	U	3		1	
a			b	c	d						e		f			g	h			

a	Design
R D V	Detached sensor electronics "Classic"

b	Design
C	Threaded flange M18×1.5-6g (A/F 46)
D	Threaded flange ¾"-16 UNF-3A (A/F 46)
M	Threaded flange M18×1.5-6g (A/F 24)
S	Pressure fit flange Ø 26.9 mm f6
T	Threaded flange ¾"-16 UNF-3A (A/F 23)

c	Mechanical options
For side cable entry	
A	PUR cable with M16 connector, 250 mm length
B	PUR cable with M16 connector, 400 mm length
C	PUR cable with M16 connector, 600 mm length
For bottom cable entry	
2	Single wires with flat connector, 65 mm length
4	Single wires with flat connector, 170 mm length
5	Single wires with flat connector, 230 mm length
6	Single wires with flat connector, 350 mm length

d	Stroke length
X X X X M	Flange »S«: 0025...2540 mm Flange »C«, »D«, »M«, »T«: 0025...5080 mm

Stroke length (mm)	Ordering steps
25... 500 mm	5 mm
500... 750 mm	10 mm
750...1000 mm	25 mm
1000...2500 mm	50 mm
2500...5080 mm	100 mm

X X X X U	Flange »S«: 001.0...100.0 in. Flange »C«, »D«, »M«, »T«: 001.0...200.0 in.
-----------	---

Stroke length (in.)	Ordering steps
1... 20 in.	0.2 in.
20... 30 in.	0.4 in.
30... 40 in.	1.0 in.
40...100 in.	2.0 in.
100...200 in.	4.0 in.

Non standard stroke lengths are available;  
must be encoded in 5 mm/0.1 in. increments

e	Number of magnets
X X	01...30 position(s) (1...30 magnet(s))

f	Connection type
D 5 6	2×M12 female connectors (D-coded), 1×M8 male connector
D 5 8	2×M12 female connectors (D-coded), 1×M12 male connector (A-coded)

g	System
1	Standard

h	Output
U 3 0 1	POWERLINK, position and velocity (1...30 magnet(s))
U 3 1 1	POWERLINK, position and velocity, internal linearization (1...30 magnet(s))

#### NOTICE

- Specify the number of magnets for your application and order the magnets separately.
- The number of magnets is limited by the stroke length.  
The minimum allowed distance between magnets (i.e. front face of one to the front face of the next one) is 75 mm (3 in.).
- Use magnets of the same type for multi-position measurement.
- If the option for internal linearization (U311) in **h** "Output" is chosen, select a suitable magnet.

### 3.7 Nameplate



Fig. 1: Example of nameplate of R-Series V RH5 sensor with POWERLINK output

### 3.8 Approvals

- CE declaration
- EPSG certified
- UL certified
- UKCA declaration

### 3.9 Scope of delivery

#### RP5 (profile sensor):

- Sensor
- Position magnet (not for RP5 with design »O«)
- 2 mounting clamps up to 1250 mm (50 in.) stroke length +  
1 mounting clamp for each 500 mm (20 in.) additional stroke length

#### RH5 (rod sensor):

- RH5-B: Base unit (without flange & rod assembly),  
3 × socket screws M4×59
- RH5-J/M/S/T: Sensor, O-ring

#### RM5 (sensor in super shield housing):

- RM5-B: Base unit (without flange & rod assembly),  
3 × socket screws M4×59
- RM5-M/S: Sensor, O-ring

#### RF5 (improved flexible rod sensor):

- Sensor (without flange & rod assembly)
- 3 × socket screws M4×59

#### RFV (flexible rod sensor):

- RFV-B: Sensor (without flange & rod assembly),  
3 × socket screws M4×59
- RFV-M/S: Sensor (with flange & without rod assembly), O-ring

#### RDV (detached sensor electronics):

- RDV-C/D/M/T: Sensor, O-ring
- RDV-S: Sensor, O-ring, back-up ring

## 4. Product description and commissioning

### 4.1 Functionality and system design

#### Product designation

- Position sensor Temposonics® R-Series V

#### Sensor model

- Temposonics® R-Series V RP5 (profile sensor)
- Temposonics® R-Series V RH5 (rod sensor)
- Temposonics® R-Series V RM5 (sensor in super shield housing)
- Temposonics® R-Series V RF5 (improved flexible rod sensor)
- Temposonics® R-Series V RFV (flexible rod sensor)
- Temposonics® R-Series V RDV (detached sensor electronics)

#### Stroke length

- Temposonics® R-Series V RP5: 25... 6350 mm (1...250 in.)
- Temposonics® R-Series V RH5: 25... 7620 mm (1...300 in.)
- Temposonics® R-Series V RM5: 25... 7615 mm (1...299.8 in.)
- Temposonics® R-Series V RF5: 150...20,000 mm (6...787 in.)
- Temposonics® R-Series V RFV: 150...20,000 mm (6...787 in.)
- Temposonics® R-Series V RDV: 25... 5080 mm (1...200 in.)

#### Output signal

- Ethernet POWERLINK

#### Application

The Temposonics® position sensors are used for measurement and conversion of the length (position) variable in the fields of automated systems and mechanical engineering.

#### Principle of operation and system construction

The absolute, linear position sensors provided by Temposonics rely on the company's proprietary Temposonics® magnetostrictive technology, which can determine position with a high level of precision and robustness. Each Temposonics® position sensor consists of a ferromagnetic waveguide, a position magnet, a strain pulse converter and supporting electronics. The magnet, connected to the object in motion in the application, generates a magnetic field at its location on the waveguide. A short current pulse is applied to the waveguide. This creates a momentary radial magnetic field and torsional strain on the waveguide. The momentary interaction of the magnetic fields releases a torsional strain pulse that propagates the length of the waveguide. When the ultrasonic wave reaches the end of the waveguide it is converted into an electrical signal. Since the speed of the ultrasonic wave in the waveguide is precisely known, the time required to receive the return signal can be converted into a linear position measurement with both high accuracy and repeatability.

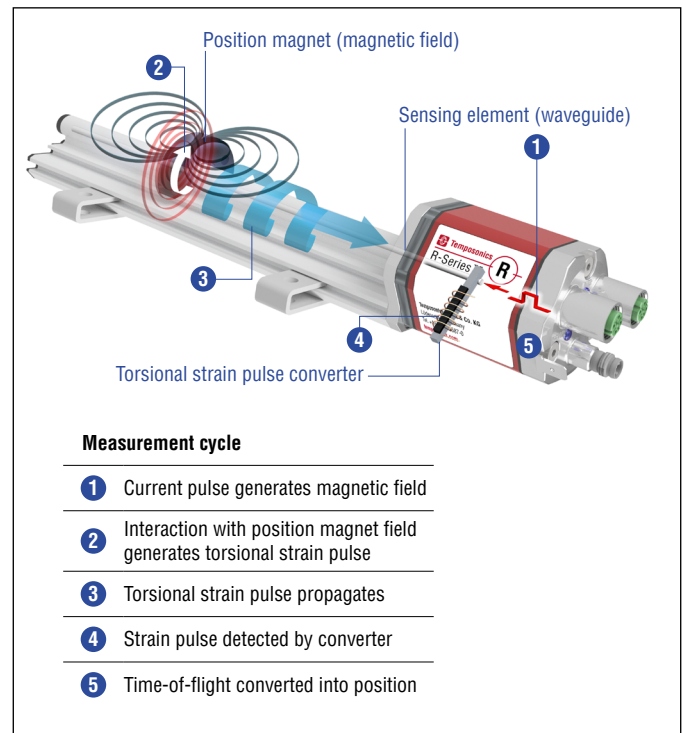

Fig. 2: Time-of-flight based magnetostrictive position sensing principle

#### Modular mechanical and electronic construction

- The sensor rod or profile protects the inner sensor element.
- The sensor electronics housing, a rugged aluminum construction, contains the complete electronic interface with active signal conditioning.
- The external position magnet is a permanent magnet. Mounted on the mobile machine part, it travels along the sensor rod or profile and triggers the measurement through the sensor rod/profile wall.
- The sensor can be connected directly to a control system. Its electronics generates a strictly position-proportional signal output between start and end position.

## 4.2 Installation and design of Temposonics® RP5

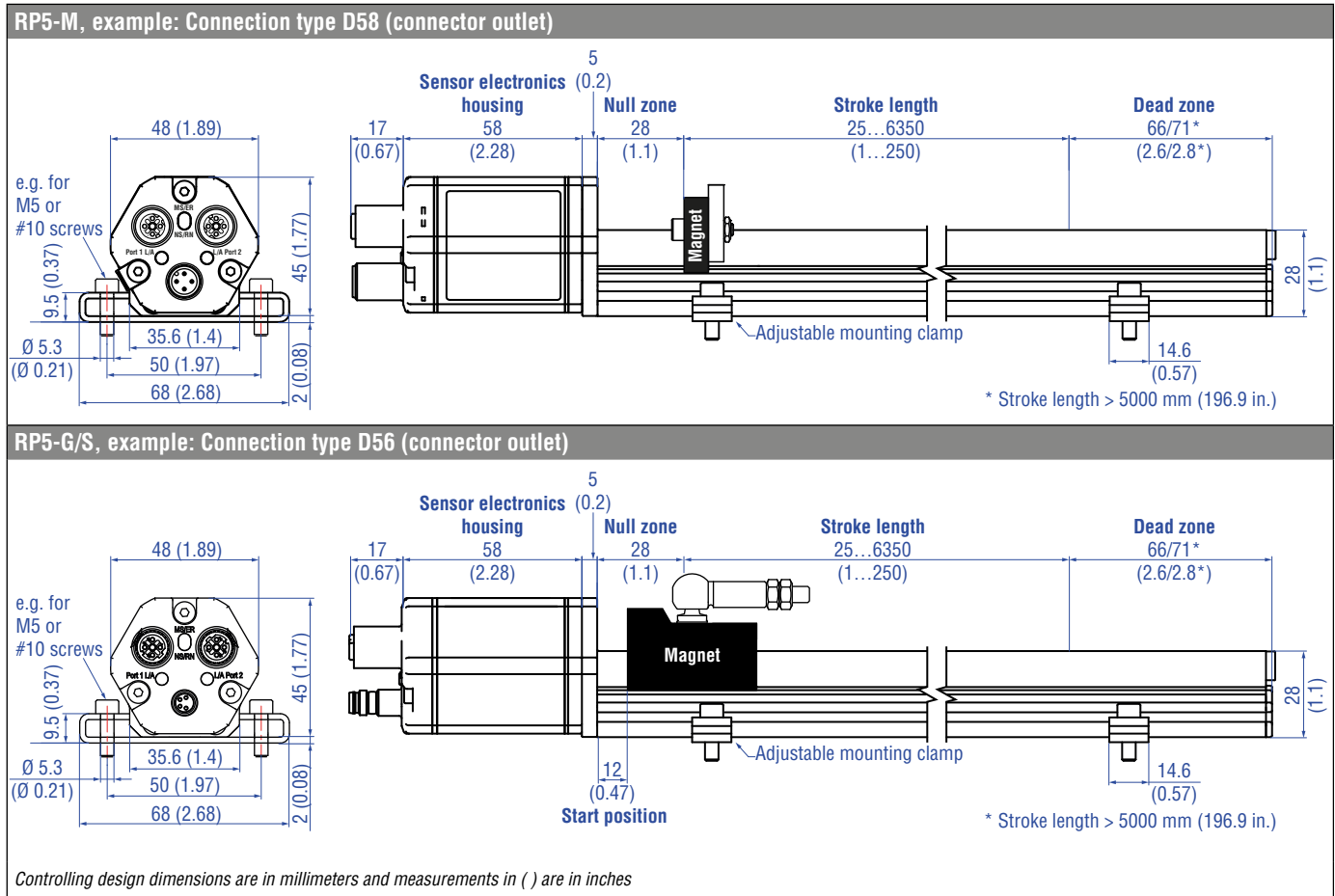

Fig. 3: Temposonics® RP5 with U-magnet and magnet slider

### Installation of RP5

The position sensor can be installed in any position. Normally, the sensor is firmly installed and the position magnet is fastened to the mobile machine part. Thus it can travel along the sensor profile. The sensor is fitted on a flat machine surface using the mounting clamps (Fig. 4). A length-dependent number of these clamps are delivered with the sensor and must be distributed over the profile at regular distances. For fastening use M5×20 screws to DIN 6912 that should be tightened with a fastening torque of 5 Nm.

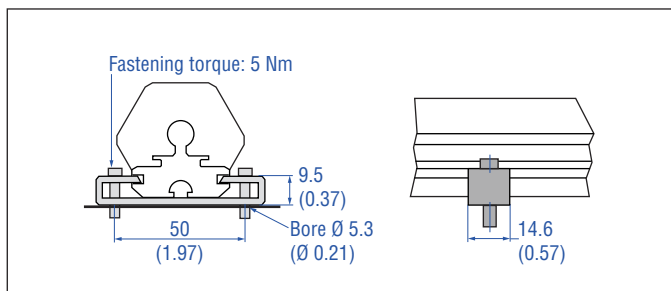

Fig. 4: Mounting clamps (part no. 400 802) with cylinder screw M5×20

### Alternative:

If only limited space is available, the profile sensor can be mounted also via the T-rail in the profile bottom using an T-slot nut M5 (part no. 401 602) or a sliding block (Fig. 5).

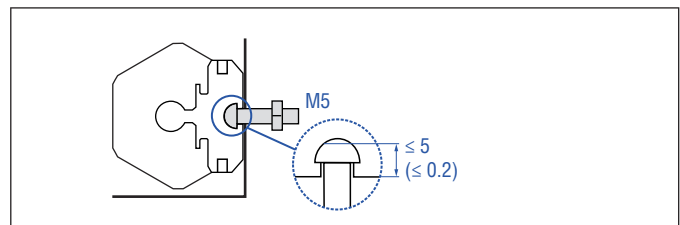

Fig. 5: T-slot nut M5 (part no. 401 602)

### NOTICE

Take care to mount the sensor in an axially parallel position to avoid damage to magnet and sensor.

4.3 Installation and design of Temposonics® RH5

RH5-M/S-A/F/V – RH5 with threaded flange M18×1.5-6g or ¾"-16 UNF-3A, example: Connection type D58 (connector outlet)

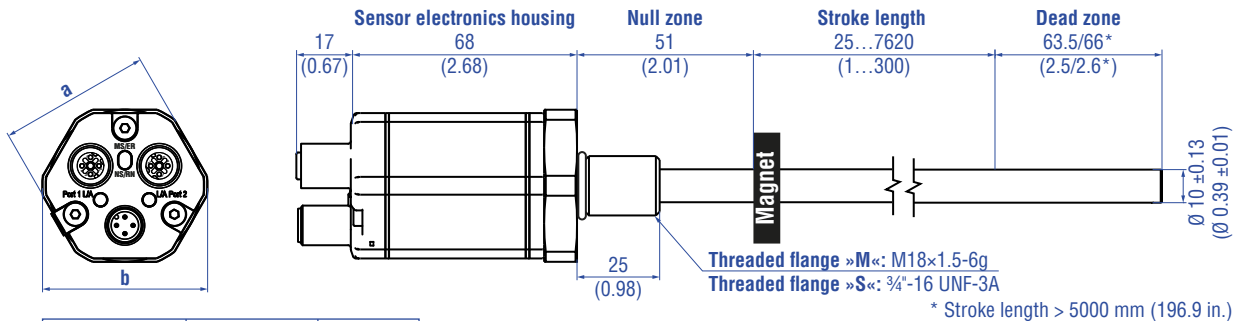

\* Stroke length > 5000 mm (196.9 in.)

RH5-T-A/F/V – RH5 with threaded flange ¾"-16 UNF-3A with raised-face, example: Connection type D56 (connector outlet)

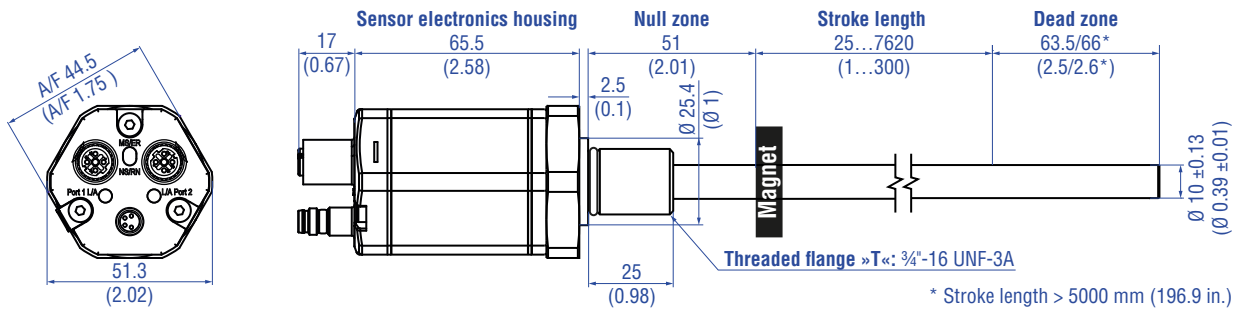

\* Stroke length > 5000 mm (196.9 in.)

Mechanical option »B«: Bushing on rod end for threaded flange M18×1.5-6g or ¾"-16 UNF-3A

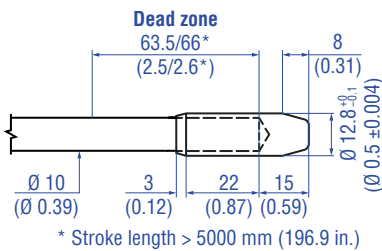

\* Stroke length > 5000 mm (196.9 in.)

Mechanical option »M«: Thread M4 at rod end for threaded flange M18×1.5-6g or ¾"-16 UNF-3A

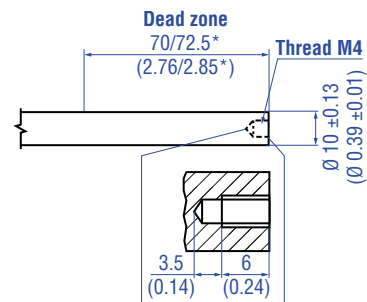

\* Stroke length > 5000 mm (196.9 in.)

Controlling design dimensions are in millimeters and measurements in ( ) are in inches

Fig. 6: Temposonics® RH5 with ring magnet, part 1

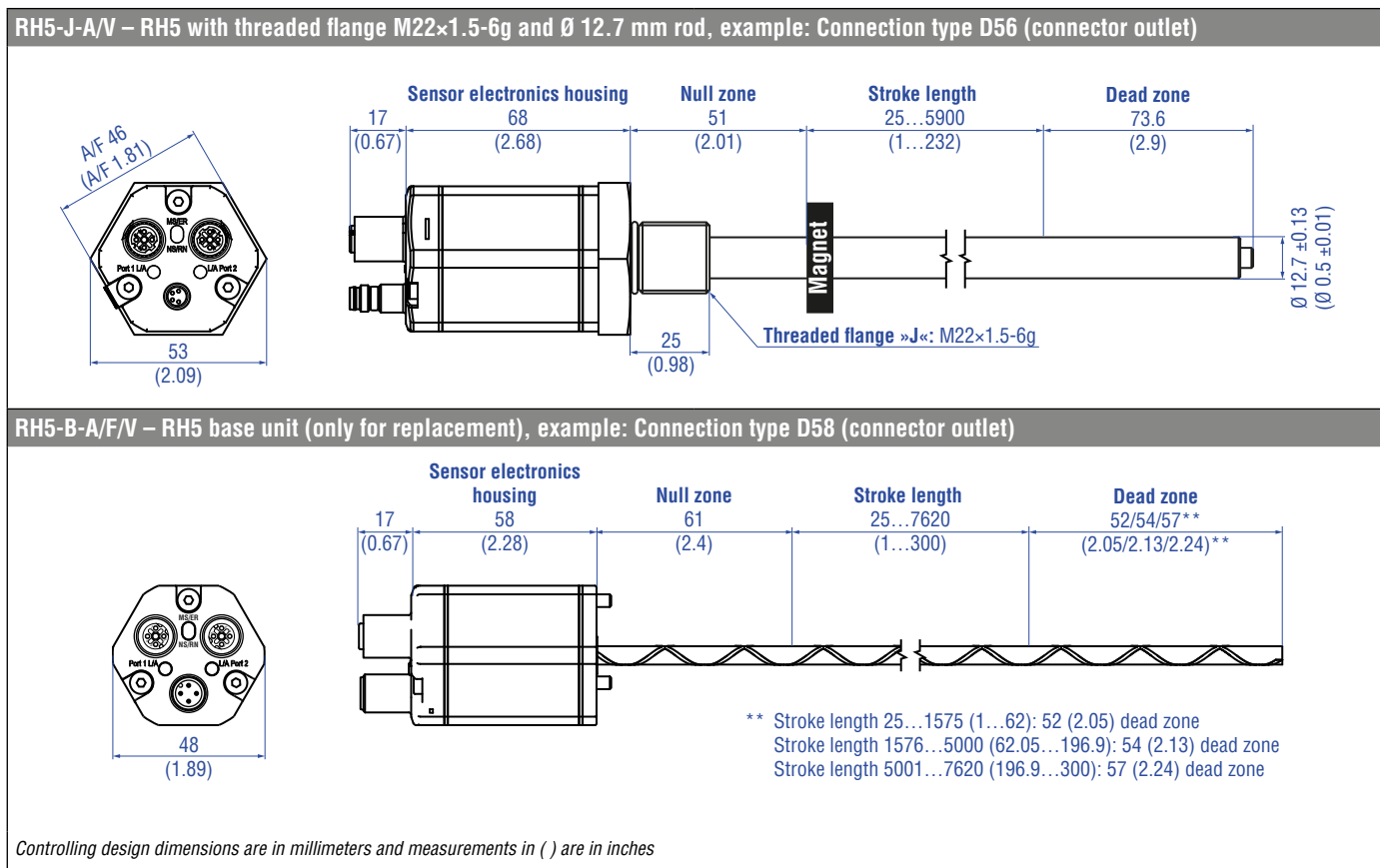

Fig. 7: Temposonics® RH5 with ring magnet, part 2

### Installation of RH5 with threaded flange

Fix the sensor rod via threaded flange M18×1.5-6g, M22×1.5-6g or ¾"-16 UNF-3A. Note the fastening torque shown in Fig. 8. Lightly oil the thread before tightening.

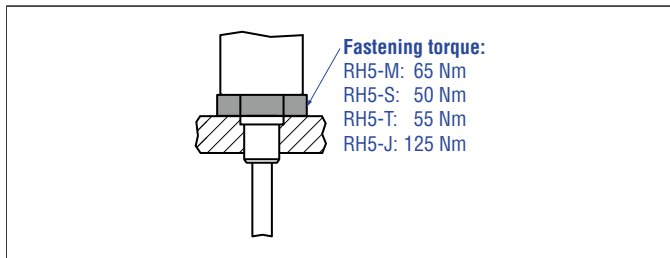

Fig. 8: Mounting example of threaded flange

### Installation of a rod-style sensor in a fluid cylinder

The rod-style version has been developed for direct stroke measurement in a fluid cylinder. Mount the sensor via threaded flange or a hex nut.

- Mounted on the face of the piston, the position magnet travels over the rod without touching it and indicates the exact position through the rod wall – independent of the hydraulic fluid.

- The pressure resistant sensor rod is installed into a bore in the piston rod.
- The base unit is mounted by means of three screws. It is the only part that needs to be replaced if servicing is required, i.e. the hydraulic circuit remains closed. For more information see chapter "4.10.1. Replacement of base unit on the RH5/RFV/RF5 model" on page 40.

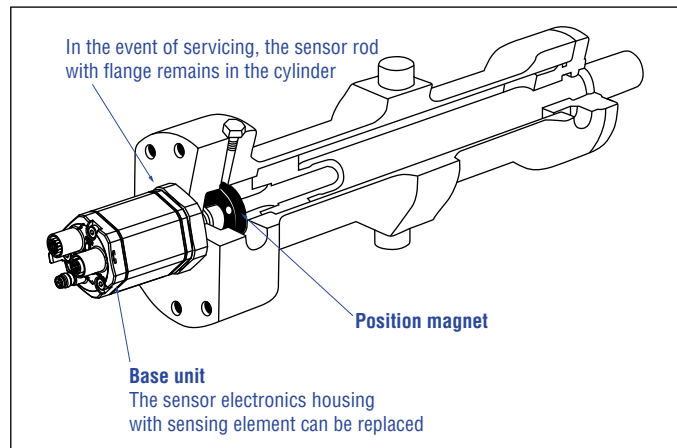

Fig. 9: Sensor in cylinder

### Hydraulics sealing

There are two ways to seal the flange contact surface (Fig. 10):

1. A sealing by using an O-ring (e.g. 22.4 × 2.65 mm (0.88 × 0.1 in.), 25.07 × 2.62 mm (0.99 × 0.1 in.)) in a cylinder end cap groove.
2. A sealing by using an O-ring in the undercut.
  - For threaded flange (3/4"-16 UNF-3A):  
O-ring 16.4 × 2.2 mm (0.65 × 0.09 in.) (part no. 560 315)
  - For threaded flange (M18×1.5-6g):  
O-ring 15.3 × 2.2 mm (0.60 × 0.09 in.) (part no. 401 133)
  - For threaded flange (M22×1.5-6g):  
O-ring 19.2 × 2.2 mm (0.76 × 0.09 in.) (part no. 561 337)

In the case of threaded flanges M18×1.5-6g or M22×1.5-6g, provide a screw hole based on ISO 6149-1 (Fig. 11). See ISO 6149-1 for further information.

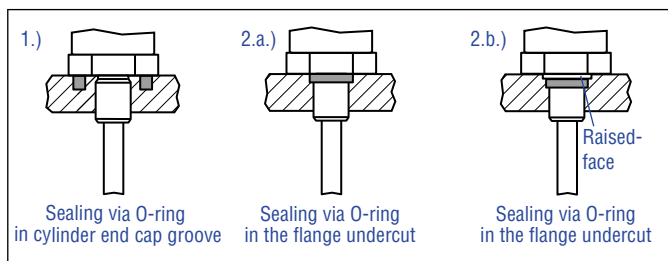

Fig. 10: Possibilities of sealing for threaded flange with flat face 1. + 2.a. (RH5-J/M/S) and with raised-face 2.b. (RH5-T)

- Seat the flange contact surface completely on the cylinder mounting surface.
- The cylinder manufacturer determines the pressure-resistant gasket (copper gasket, O-ring, etc.).
- The position magnet should not grind on the sensor rod.
- The piston rod drilling  
 (RH5-M/S/T-A/F/M/V with rod Ø 10 mm: ≥ Ø 13 mm (≥ Ø 0.51 in.);  
 RH5-M/S/T-B with rod Ø 10 mm: ≥ Ø 16 mm (≥ Ø 0.63 in.);  
 RH5-J-A/V with rod Ø 12.7 mm: ≥ Ø 16 mm (≥ Ø 0.63 in.))  
 depends on the pressure and piston speed.
- Adhere to the information relating to operating pressure.
- Protect the sensor rod against wear.

Notice for metric threaded flanges									
Thread (d <sub>1</sub> ×P)	d <sub>2</sub>	d <sub>3</sub>	d <sub>4</sub>	d <sub>5</sub>	L <sub>1</sub>	L <sub>2</sub>	L <sub>3</sub>	L <sub>4</sub>	Z°
				+0.1 0	+0.4 0				±1°
<b>RH5-M-A/F/M/V</b>									
M18×1.5	55	≥ 13	24.5	19.8	2.4	28.5	2	26	15°
<b>RH5-M-B</b>									
M18×1.5	55	≥ 16	24.5	19.8	2.4	28.5	2	26	15°
<b>RH5-J-A/V</b>									
M22×1.5	55	≥ 16	27.5	23.8	2.4	28.5	2	26	15°

Controlling design dimensions are in millimeters

Fig. 11: Notice for metric threaded flange M18×1.5-6g/M22×1.5-6g based on DIN ISO 6149-1



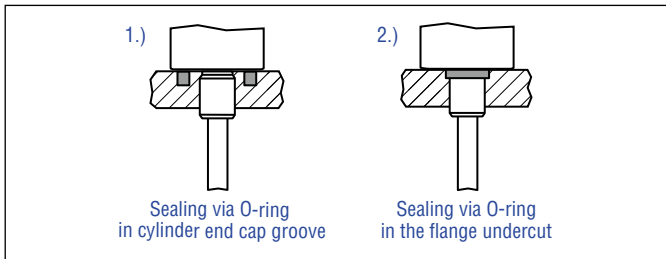

Fig. 15: Possibilities of sealing

- Seat the flange contact surface completely on the cylinder mounting surface.
- The cylinder manufacturer determines the pressure-resistant gasket (copper gasket, O-ring, etc.).
- The position magnet should not grind on the sensor rod.
- The piston rod drilling (RM5-M/S with rod  $\varnothing$  10 mm:  $\geq \varnothing$  13 mm ( $\geq \varnothing$  0.51 in.)) depends on the pressure and piston speed.
- Adhere to the information relating to operating pressure.
- Protect the sensor rod against wear.

**Notice for metric threaded flanges**

Thread ( $d_1 \times P$ )	$d_2$	$d_3$	$d_4$	$d_5$ +0.1 0	$L_1$ +0.4 0	$L_2$	$L_3$	$L_4$	$Z^\circ$ $\pm 1^\circ$
<b>RM5-M</b>									
M18×1.5	55	$\geq 13$	24.5	19.8	2.4	28.5	2	26	15°

Controlling design dimensions are in millimeters

Fig. 16: Notice for metric threaded flange M18×1.5-6g based on DIN ISO 6149-1

4.5 Installation and design of Tempsonics® RF5

RF5-B – RF5 base unit (without flange & rod assembly), example: Connection type D56 (connector outlet)

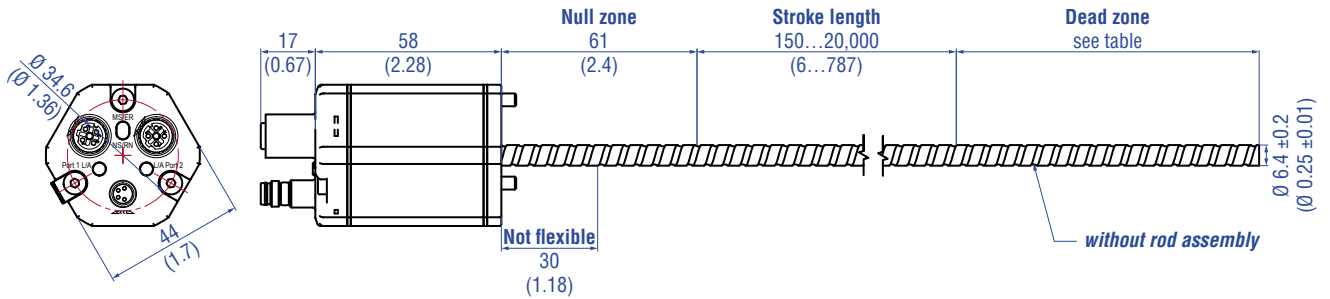

Stroke length	Tolerance of total length	Dead zone
Up to 7620 mm (300.00 in.)	±5 mm (0.20 in.)	94 mm (3.70 in.)
Up to 10,000 mm (393.70 in.)	±10 mm (0.39 in.)	100 mm (3.94 in.)
Up to 15,000 mm (590.55 in.)	±15 mm (0.59 in.)	120 mm (4.72 in.)
Up to 20,000 mm (787.00 in.)	±20 mm (0.79 in.)	140 mm (5.51 in.)

Note: Tolerance of total length has no influence on the stroke length.

RF5-B – RF5 base unit (without flange & rod assembly), example: Connection type D58 (connector outlet)

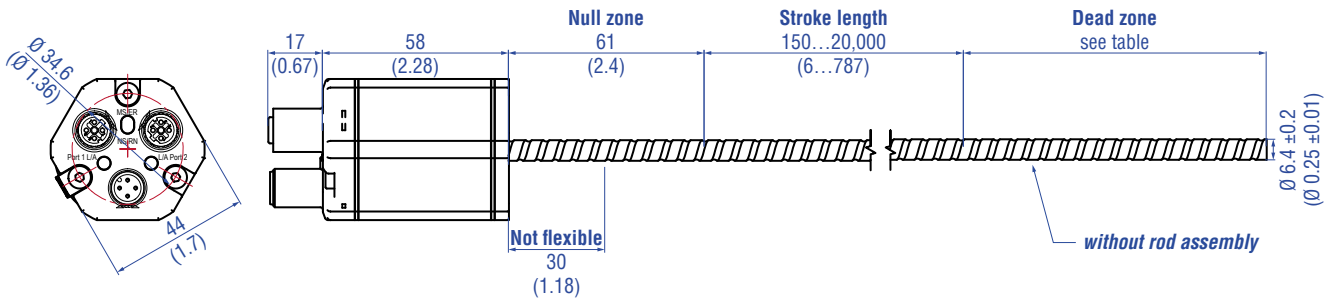

Stroke length	Tolerance of total length	Dead zone
Up to 7620 mm (300.00 in.)	±5 mm (0.20 in.)	94 mm (3.70 in.)
Up to 10,000 mm (393.70 in.)	±10 mm (0.39 in.)	100 mm (3.94 in.)
Up to 15,000 mm (590.55 in.)	±15 mm (0.59 in.)	120 mm (4.72 in.)
Up to 20,000 mm (787.00 in.)	±20 mm (0.79 in.)	140 mm (5.51 in.)

Note: Tolerance of total length has no influence on the stroke length.

Controlling design dimensions are in millimeters and measurements in ( ) are in inches

Fig. 17: Tempsonics® RF5

### Installation of RF5

Note the following information when mounting and handling an RF5 sensor:

1. Always insert the flexible sensor rod in a support tube (e.g. sensor rod HD/HL/HP or HFP profile). The support tube has to be made of non-magnetic material and has to have an inside diameter of minimum 9.4 mm (0.37 in.) (Fig. 18). The support tube can be straight or bent.
2. Do never bend beyond the minimum bending radius of 100 mm (3.94 in.).
3. Note the minimum distance to a spatial limitation of 150 mm (5.91 in.), when mounting/dismounting the sensor. The recommended distance is 200 mm (7.87 in.) (Fig. 19).
4. Note the non-flexible area of the sensor rod from the flange of 30 mm (1.18 in.) (for RF5-B).

#### NOTICE

Bending radii < 100 mm (3.94 in.) during handling, installation or operation will damage the flexible sensor rod and thus impair the function of the sensor.

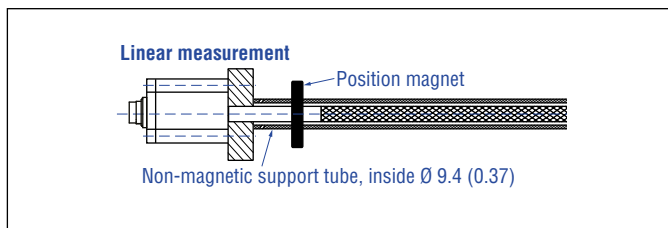

Fig. 18: Sensor with support tube

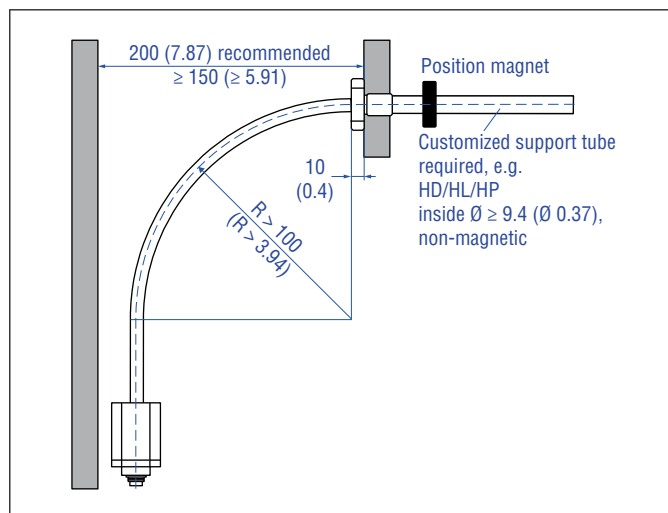

Fig. 19: Clearances for installation and handling

### Mounting an RF5 sensor

There are three ways to mount the RF5 sensor:

1. Installation of the RF5-B base unit in a support tube provided by the customer
2. Installation of the RF5-B base unit in a sensor rod HD/HL/HP or HFP profile
3. Installation of the RF5-B base unit with threaded flange M18×1.5-6g or threaded flange ¾"-16 UNF-3A

These installation options are described below.

#### 1. Installation of the RF5-B base unit in a support tube provided by the customer

1. Insert the flexible sensor rod in a support tube.
2. When inserting the flexible sensor rod, hold it close to the flange and insert it slowly into the support tube (Fig. 20). This allows air in the support tube to escape.

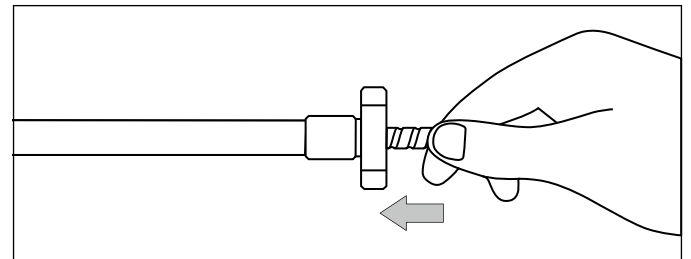

Fig. 20: Hold the flexible sensor rod close to the flange when inserting it

3. Mount the sensor electronics housing using the three M4×59 hexagon socket screws made of non-magnetic material. Tightening torque: 1.4 Nm (Fig. 21). Secure the screws before installation, e.g. with Loctite 243. Remove the three knurled nuts beforehand.

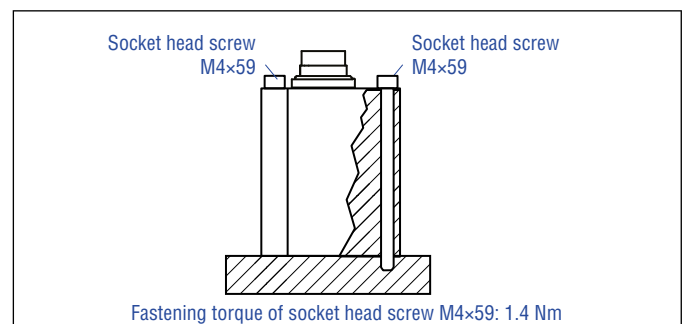

Fig. 21: Mounting with socket head screws M4×59

- Ensure that the O-ring seal (part no. 562 003) is correctly inserted in the groove on the sensor electronics housing before inserting the base unit into the support tube and attaching the sensor electronics (Fig. 22).

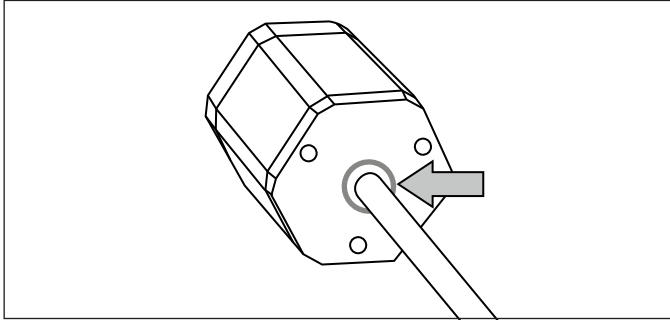

Fig. 22: Correct position of the O-ring in the groove of the sensor electronics housing

**2. RF5-B with sensor rod HD/HL/HP or HFP profile**  
(see “4.15 Frequently ordered accessories for Temposonics® RF5”) Using the HD/HL/HP sensor rod or the HFP profile offers you the advantage that the flexible sensor rod is guided in a suitable protective tube.

- When inserting the flexible sensor rod, hold it close to the flange and insert it slowly into the support tube (Fig. 20). This allows air in the support tube to escape.
- Mount the sensor electronics housing to the sensor rod or HFP profile using three M4×59 hexagon socket screws made of non-magnetic material: Tightening torque: 1.4 Nm (Fig. 21). Secure the screws before installation, e.g. with Loctite 243. Remove the three knurled nuts beforehand.
- Ensure that the O-ring seal (part no. 562 003) is correctly inserted in the groove on the sensor electronics before inserting the base unit into the support tube or the HFP profile and attaching the sensor electronics (Fig. 22).

Details on installing the sensor rod HD/HL/HP or the HFP profile follow.

### Installation of an RF5 sensor with sensor rod HD/HL/HP in a fluid cylinder

The rod-style version has been developed for direct stroke measurement in a fluid cylinder. Fix the sensor rod via threaded flange M18×1.5-6g or 3/4"-16 UNF-3A. Note the fastening torque shown in Fig. 23. Lightly oil the thread before tightening.

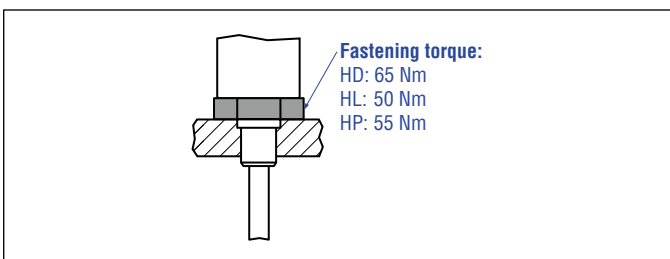

Fig. 23: Mounting example of threaded flange

- Mounted on the face of the piston, the position magnet travels over the rod without touching it and indicates the exact position through the rod wall – independent of the hydraulic fluid.
- The pressure resistant sensor rod is installed into a bore in the piston rod.
- The base unit is mounted by means of three screws. It is the only part that needs to be replaced if servicing is required, i.e. the hydraulic circuit remains closed. For more information see chapter “4.10.1. Replacement of base unit on the RH5/RFV/RF5 model” on page 40
- Seat the flange contact surface completely on the cylinder mounting surface.
- The cylinder manufacturer determines the pressure-resistant gasket (copper gasket, O-ring, etc.).
- The position magnet should not grind on the sensor rod.
- The piston rod drilling for RF5 sensors with sensor rod (outer diameter 12.7 mm (0.5 in.)) is  $\geq 16$  mm ( $\geq 0.63$  in.). The borehole depends on the pressure and piston speed.
- Adhere to the information relating to operating pressure.
- Protect the sensor rod against wear.

### Hydraulics sealing when using an RF5 sensor in a sensor rod HD/HL/HP

There are two ways to seal the flange contact surface (Fig. 24):

- A sealing by using an O-ring  
(e.g. 22.4 × 2.65 mm (0.88 × 0.1 in.), 25.07 × 2.62 mm (0.99 × 0.1 in.)) in a cylinder end cap groove.
- A sealing by using an O-ring in the flange undercut.  
For threaded flange (3/4"-16 UNF-3A) »S«:  
O-ring 16.4 × 2.2 mm (0.65 × 0.09 in.) (part no. 560 315)  
For threaded flange (M18×1.5-6g) »M«:  
O-ring 15.3 × 2.2 mm (0.60 × 0.09 in.) (part no. 401 133)

In the case of threaded flange M18×1.5-6g provide a screw hole based on ISO 6149-1 (Fig. 25). See ISO 6149-1 for further information.

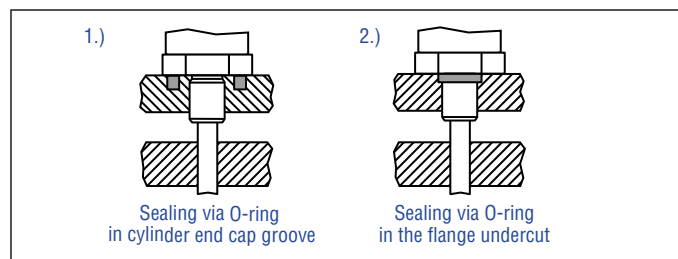

Fig. 24: Possibilities of sealing

Notice for metric threaded flanges									
Thread ( $d_1 \times P$ )	$d_2$	$d_3$	$d_4$	$d_5$ +0.1 0	$L_1$ +0.4 0	$L_2$	$L_3$	$L_4$	$Z^\circ$ $\pm 1^\circ$
<b>Optional sensor rod HD</b>									
M18×1.5	55	≥ 16	24.5	19.8	2.4	28.5	2	26	15°

Controlling design dimensions are in millimeters

Fig. 25: Notice for metric threaded flange M18×1.5-6g based on DIN ISO 6149-1

### Installation of RF5 sensor with HFP profile

The RF5 sensor with HFP profile can be installed in any position. The HFP profile is firmly installed and the position magnet is fastened to the mobile machine part. Thus it can travel along the sensor profile. The sensor is fitted on a flat machine surface using the mounting clamps (Fig. 26). A length-dependent number of these clamps are delivered with the sensor and must be distributed over the profile at regular distances. For fastening use M5×20 screws to DIN 6912 that should be tightened with a fastening torque of 5 Nm.

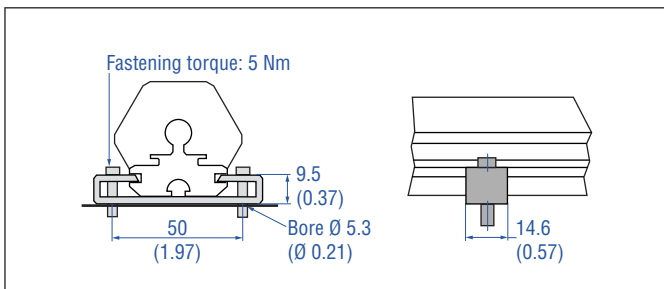

Fig. 26: Mounting clamps (part no. 400 802) with cylinder screw M5×20

### 3. RF5-B with threaded flange M18×1.5-6g (part no. 404 874) or threaded flange 3/4"-16 UNF-3A (part no. 404 875)

Fix the sensor rod via threaded flange M18×1.5-6g or 3/4"-16 UNF-3A. Note the fastening torque:

- Threaded flange M18×1.5-6g (part no. 404 874): 65 Nm
- Threaded flange 3/4"-16 UNF-3A (part no. 404 875): 50 Nm

Lightly oil the thread before tightening.

- Insert the flexible sensor rod in a support tube.
- When inserting the flexible sensor rod, hold it close to the flange and insert it slowly into the support tube (Fig. 20). This allows air in the support tube to escape.
- Mount the sensor via flange using the three M4×59 hexagon socket screws made of non-magnetic material. Tightening torque: 1.4 Nm (Fig. 21). Remove the three knurled nuts beforehand.
- Ensure that the O-ring seal (part no. 562 003) is correctly inserted in the groove on the sensor electronics housing before inserting the base unit into the support tube and attaching the sensor electronics (Fig. 22).

### NOTICE

To fulfill the requirements of EMC standards for emission and immunity the following points are necessary:

- The sensor electronics housing has to be connected to machine ground (Fig. 74).
- Embed the flexible sensor element in an appropriately shielded environment, e.g. in a sensor rod HD/HL/HP or HFP profile.

4.6 Installation and design of Temposonics® RFV

RFV-B – RFV base unit (without flange & rod assembly), example: Connection type D56 (connector outlet)

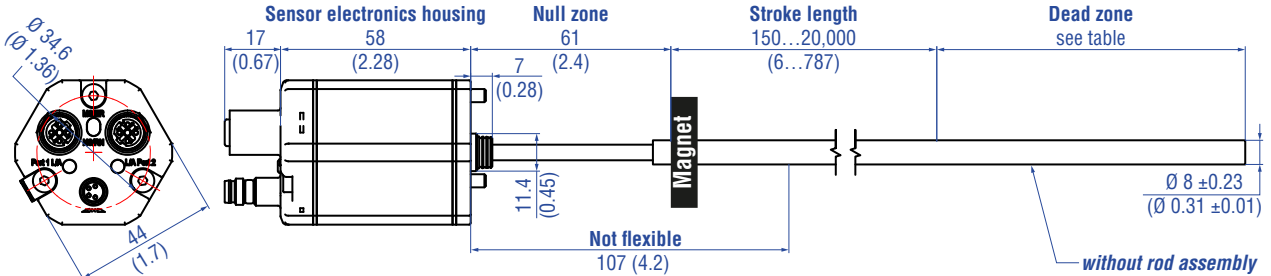

Stroke length	Tolerance of total length	Dead zone
Up to 7620 mm (300.00 in.)	+8 mm (0.31 in.)/ -5 mm (0.20 in.)	94 mm (3.70 in.)
Up to 10,000 mm (393.70 in.)	+15 mm (0.59 in.)/-15 mm (0.59 in.)	100 mm (3.94 in.)
Up to 15,000 mm (590.55 in.)	+15 mm (0.59 in.)/-30 mm (1.18 in.)	120 mm (4.72 in.)
Up to 20,000 mm (787.00 in.)	+15 mm (0.59 in.)/-45 mm (1.77 in.)	140 mm (5.51 in.)

Note: Tolerance of total length has no influence on the stroke length.

RFV-M/S – RFV with threaded flange M18×1.5-6g or 3/4"-16 UNF-3A (without rod assembly), example: Connection type D58 (connector outlet)

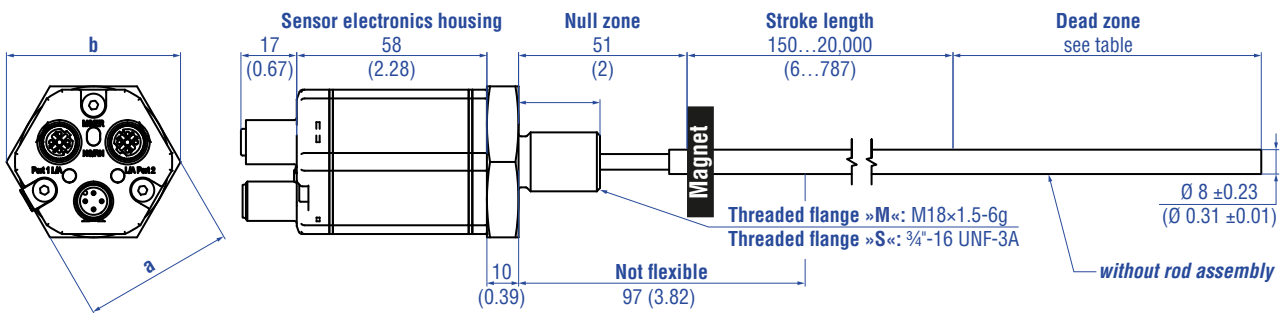

Threaded flange	a	b
»M«	A/F 46 (1.81)	53 (2.09)
»S«	A/F 44.5 (1.75)	51.3 (2.02)

Stroke length	Tolerance of total length	Dead zone
Up to 7620 mm (300.00 in.)	+8 mm (0.31 in.)/ -5 mm (0.20 in.)	94 mm (3.70 in.)
Up to 10,000 mm (393.70 in.)	+15 mm (0.59 in.)/-15 mm (0.59 in.)	100 mm (3.94 in.)
Up to 15,000 mm (590.55 in.)	+15 mm (0.59 in.)/-30 mm (1.18 in.)	120 mm (4.72 in.)
Up to 20,000 mm (787.00 in.)	+15 mm (0.59 in.)/-45 mm (1.77 in.)	140 mm (5.51 in.)

Note: Tolerance of total length has no influence on the stroke length.

Controlling design dimensions are in millimeters and measurements in ( ) are in inches

Fig. 27: Temposonics® RFV with ring magnet

### Installation of RFV

Note the following information when mounting and handling an RFV sensor:

1. Always insert the flexible sensor rod in a support tube (e.g. sensor rod HD/HL/HP or HFP profile). The support tube has to be made of non-magnetic material and has to have an inside diameter of minimum 9.4 mm (0.37 in.) (Fig. 28). The support tube can be straight or bent.
2. Do never bend beyond the minimum bending radius of 250 mm (9.84 in.).
3. Note the minimum distance to a spatial limitation of 300 mm (11.81 in.), when mounting/dismounting the sensor. The recommended distance is 500 mm (20 in.) (Fig. 29).
4. Note the non-flexible area of the sensor rod from the flange of 107 mm (4.21 in.) (for RFV-B) respectively 97 mm (3.82 in.) (for RFV-M/S).

#### NOTICE

Smaller radiuses < 250 mm (9.84 in.) cause damage to the flexible sensor rod.

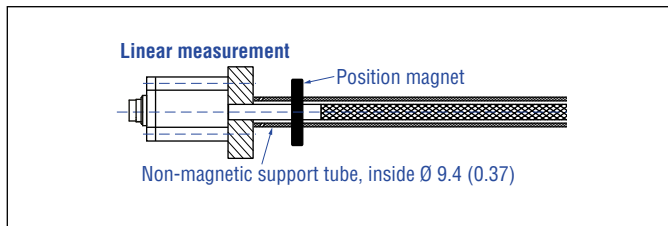

Fig. 28: Sensor with support tube

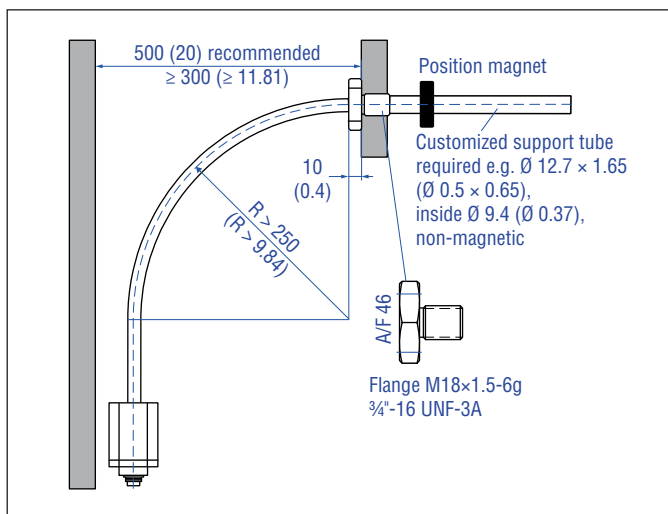

Fig. 29: Clearances for installation and handling

Controlling design dimensions are in millimeters and measurements in ( ) are in inches

### Mounting the RFV

#### 1. RFV-B

- Insert the flexible sensor rod in a support tube.
  - Mount the sensor electronics housing by means of three non-magnetic socket head screws M4x59. Fastening torque: 1.4 Nm (Fig. 30). Secure the screws, e.g. using Loctite 243, before re-installing.
- Recommendation: Seal the sensor via flange.

#### 2. RFV-B with sensor rod HD/HL/HP or HFP profile (see "4.16 Frequently ordered accessories for Temposonics® RFV")

- Advantage: The flexible sensor rod is inserted in a support tube.
- Mount the sensor electronics housing by means of three non-magnetic socket head screws M4x59. Fastening torque: 1.4 Nm (Fig. 30). Secure the screws, e.g. using Loctite 243, before re-installing.
- Installation details: see below

#### 3. RFV-M/S

- Insert the flexible sensor rod in a support tube.
- Mount the sensor via flange.
- Installation details: see below
- Please note that liquid can enter the sensor between the thread and the flexible rod.

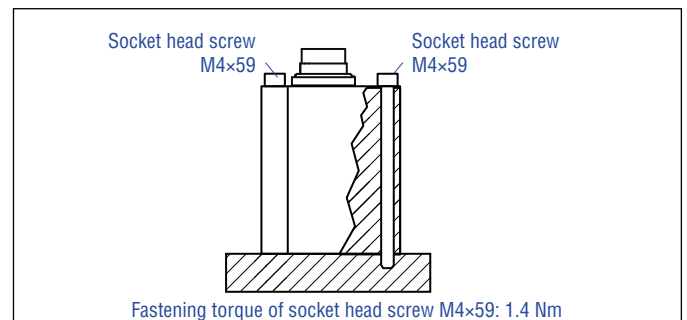

Fig. 30: Mounting with socket head screws M4x59

**NOTICE**

- To fulfill the requirements of EMC standards for emission and immunity the following points are necessary:
- The sensor electronics housing has to be connected to machine ground (Fig. 74).
  - Embed the flexible sensor element in an appropriately shielded environment, e.g. in a sensor rod HD/HL/HP or HFP profile.

**Installation of RFV with threaded flange »M«, »S«**

Fix the sensor rod via threaded flange M18×1.5-6g or ¾"-16 UNF-3A. Note the fastening torque shown in Fig. 31. Lightly oil the thread before tightening.

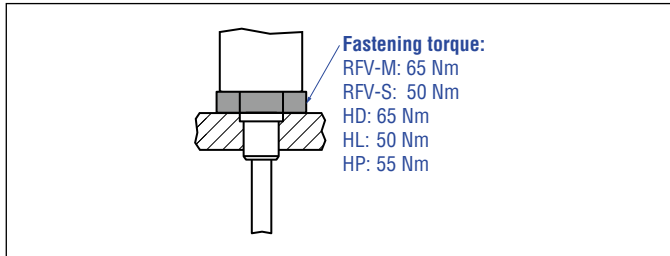

Fig. 31: Mounting example of threaded flange

**Installation of RFV sensor with sensor rod HD/HL/HP in a fluid cylinder**

The rod-style version has been developed for direct stroke measurement in a fluid cylinder. Mount the sensor via threaded flange or a hex nut.

- Mounted on the face of the piston, the position magnet travels over the rod without touching it and indicates the exact position through the rod wall – independent of the hydraulic fluid.
- The pressure resistant sensor rod is installed into a bore in the piston rod.
- The base unit is mounted by means of three screws. It is the only part that needs to be replaced if servicing is required, i.e. the hydraulic circuit remains closed. Before inserting the base unit into the sensor rod HD/HL/HP, remove the red sealing at the transition between the sensor electronics housing and the flexible sensor rod (Fig. 32). For more information see chapter “4.10.1. Replacement of base unit on the RH5/RFV/RF5 model” on page 40.
- Seat the flange contact surface completely on the cylinder mounting surface.
- The cylinder manufacturer determines the pressure-resistant gasket (copper gasket, O-ring, etc.).
- The position magnet should not grind on the sensor rod.
- The piston rod drilling for RFV sensors with sensor rod (outer diameter 12.7 mm (0.5 in.)) is ≥ 16 mm (≥ 0.63 in.). The borehole depends on the pressure and piston speed.
- Adhere to the information relating to operating pressure.
- Protect the sensor rod against wear.

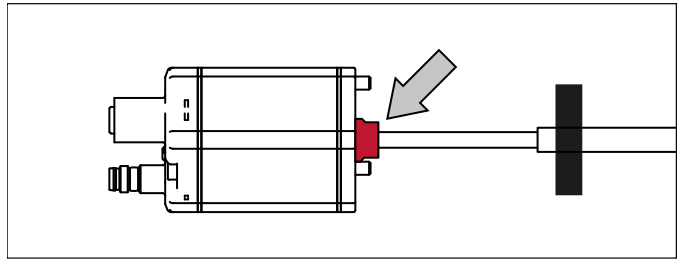

Fig. 32: Remove sealing before inserting into sensor rod HD/HL/HP

**Hydraulics sealing when using an RFV sensor in a sensor rod HD/HL/HP**

There are two ways to seal the flange contact surface (Fig. 33):

1. A sealing by using an O-ring (e.g. 22.4 × 2.65 mm (0.88 × 0.1 in.), 25.07 × 2.62 mm (0.99 × 0.1 in.)) in a cylinder end cap groove.
2. A sealing by using an O-ring in the flange undercut.  
 For threaded flange (¾"-16 UNF-3A) »S«:  
 O-ring 16.4 × 2.2 mm (0.65 × 0.09 in.) (part no. 560 315)  
 For threaded flange (M18×1.5-6g) »M«:  
 O-ring 15.3 × 2.2 mm (0.60 × 0.09 in.) (part no. 401 133)

In the case of threaded flange M18×1.5-6g, provide a screw hole based on ISO 6149-1 (Fig. 34). See ISO 6149-1 for further information.

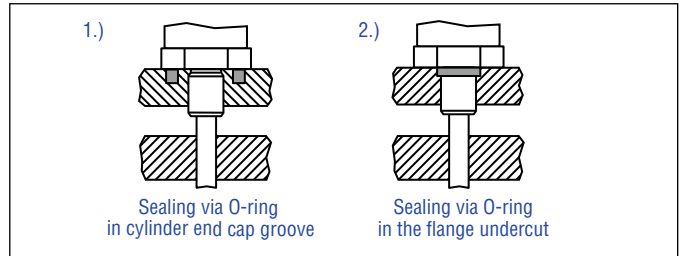

Fig. 33: Possibilities of sealing

For additional information about the accessories HFP profile and sensor rod HD/HL/HP see the accessories catalog (document part number: [551444](#)).

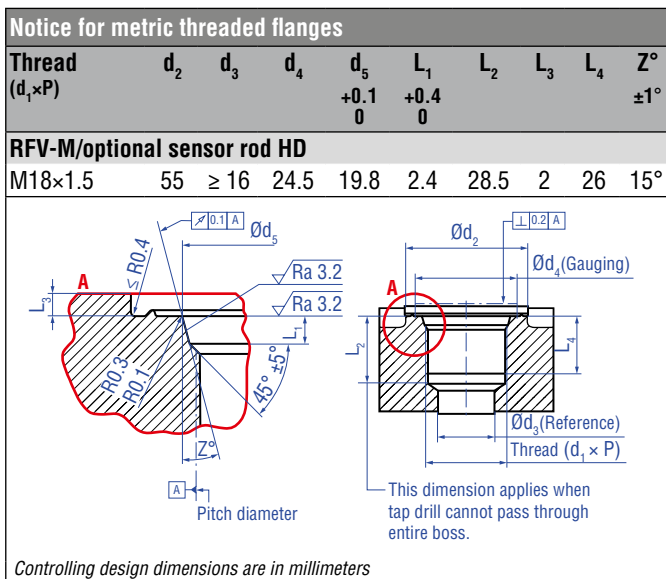

Fig. 34: Notice for metric threaded flange M18×1.5-6g based on DIN ISO 6149-1

#### Replacing an R-Series 2004 RF-C with an R-Series V RFV-B

If you are replacing the R-Series 2004 RF-C base unit with the R-Series V RFV-B base unit, note the following points:

- The R-Series 2004 RF-C base unit is attached to the system with two screws. The R-Series V RFV-B base unit is mounted to the machine with three screws.
- Therefore, we recommend using the adapter plate kit 255198. The adapter plate is used to mount the base unit RFV-B with three screws to the existing hole pattern with two screws.
  - Fasten the adapter plate to the existing hole pattern using the two M4×6 (A/F 2.5) socket head screws with a fastening torque of 1.4 Nm. Ensure that the O-ring is correctly seated between the system and the adapter plate. Secure the screws with Loctite 243.
  - Place the RFV-B base unit on the adapter plate.
  - Attach the ground lug to one screw of the base unit.
  - Screw the RFV-B base unit to the adapter plate using the three M4×59 hexagon socket head (A/F 2.5) with a fastening torque of 1.4 Nm. Ensure that the O-ring is correctly seated between the base unit and the adapter plate. Secure the screws with Loctite 243.
- The adapter plate has a thickness of 5 mm. Order the RFV-B base unit with the addition H003 to compensate for the thickness of the adapter plate: RFV-B-xxxxxx-xx-xxx-1-xxxx-H003

4.7 Installation and design of Temposonics® RDV

RDV with bottom cable entry, example: Connector D56 (connector outlet)

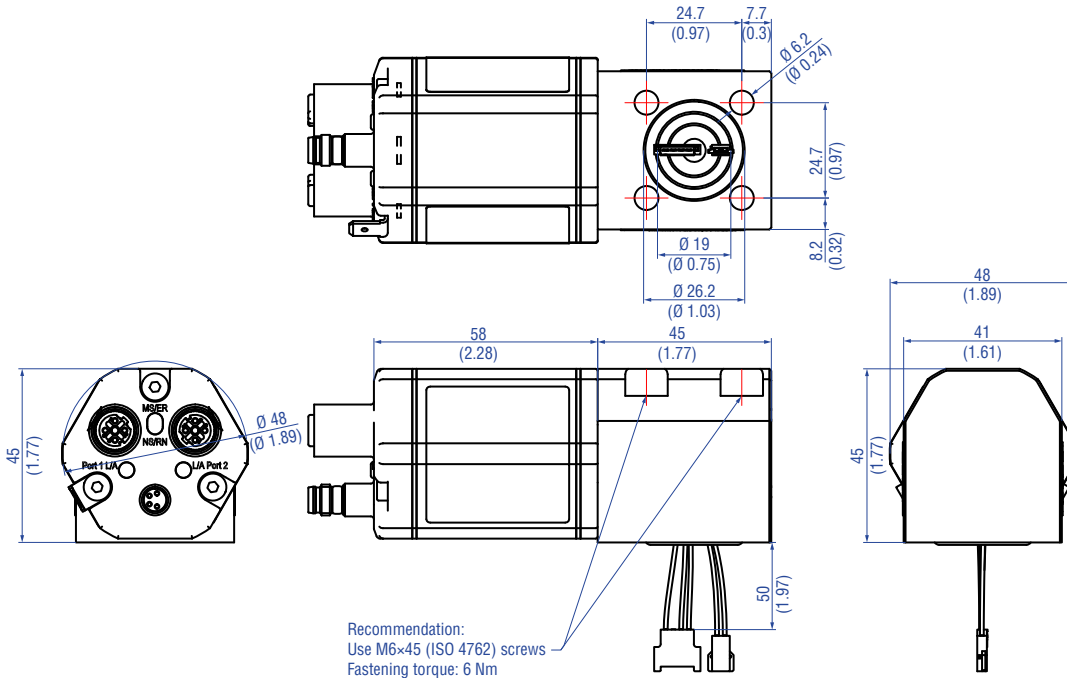

RDV with side cable entry, example: Connector D58 (connector outlet)

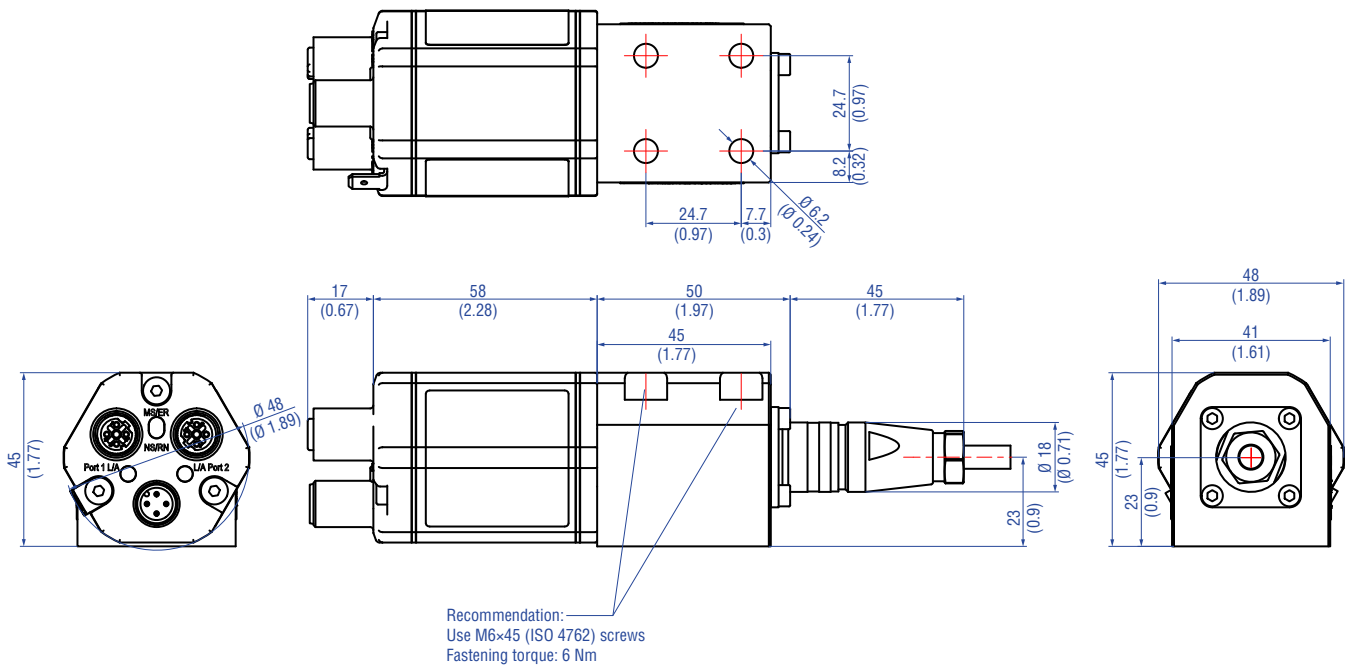

Controlling design dimensions are in millimeters and measurements in ( ) are in inches

Fig. 35: Temposonics® RDV sensor electronics housing

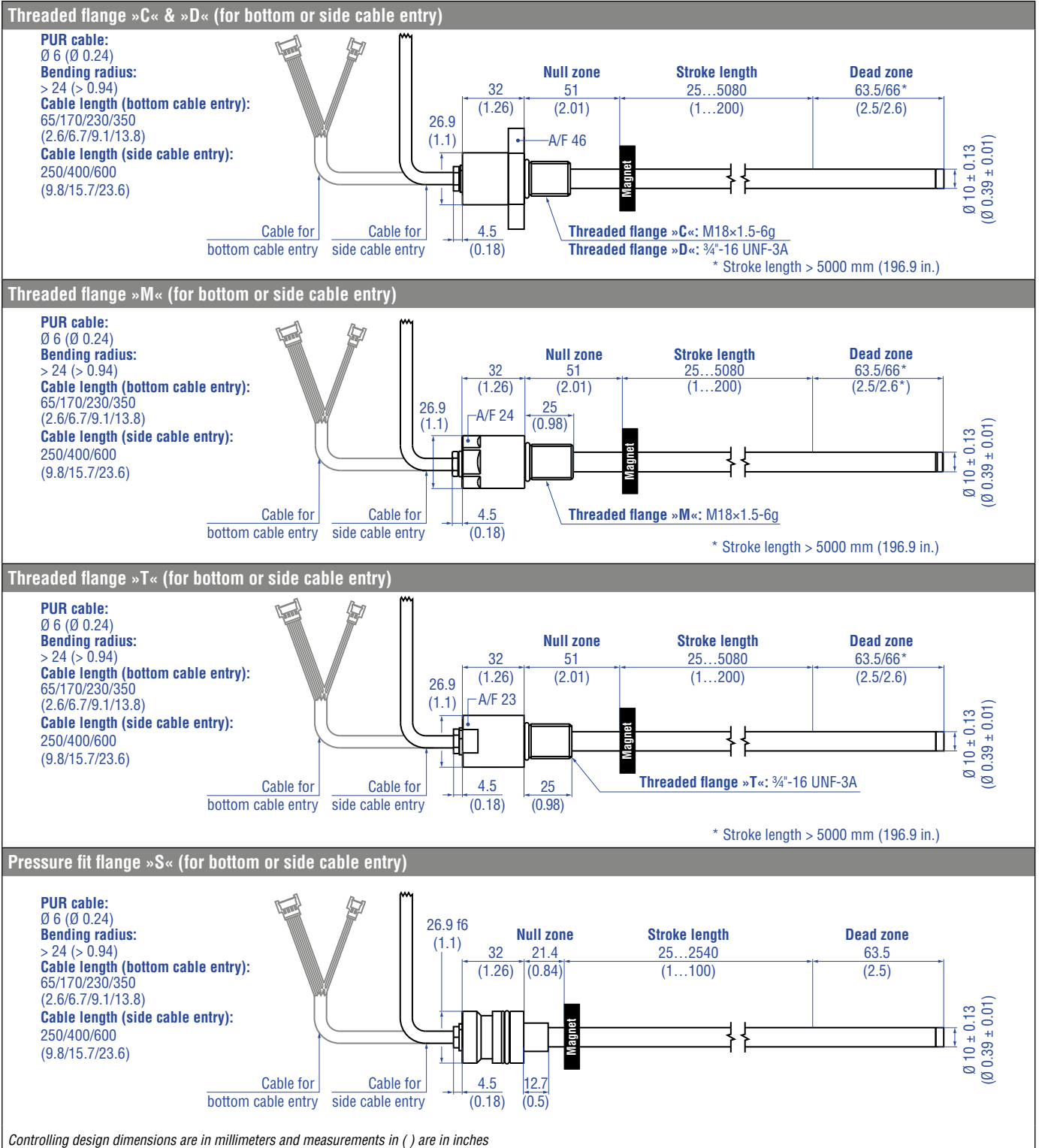
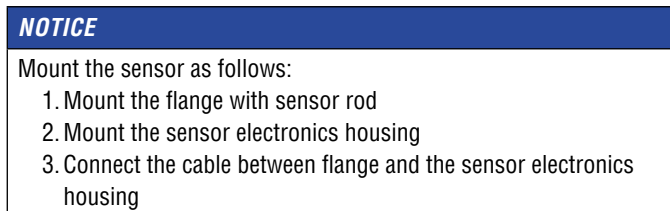
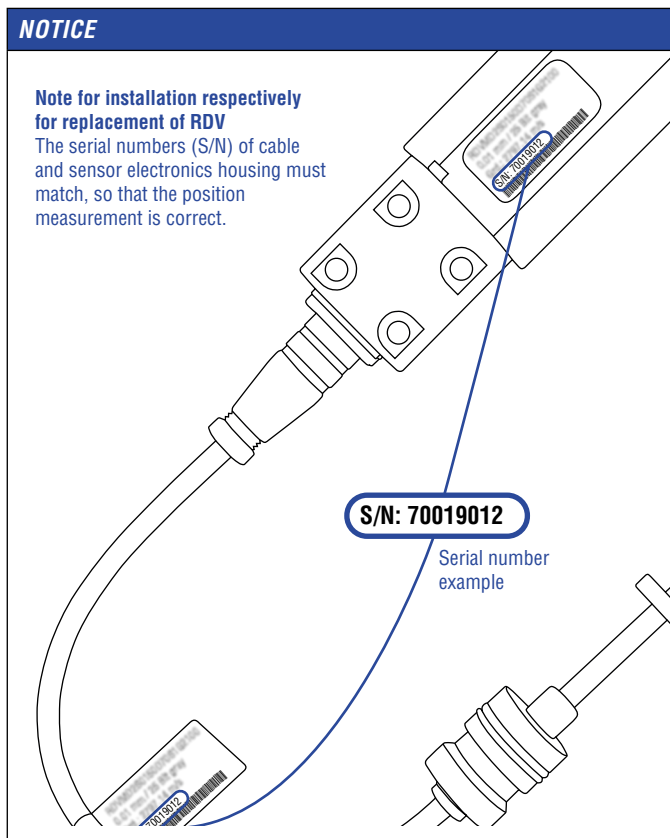

Fig. 36: Temposonics® RDV flanges



The steps mentioned above are explained in the following sections.

#### 4.7.1. Installation of RDV with threaded flange

Fix the sensor rod via threaded flange M18×1.5-6g or ¾"-16 UNF-3A. Note the fastening torque shown in Fig. 37. Lightly oil the thread before tightening.

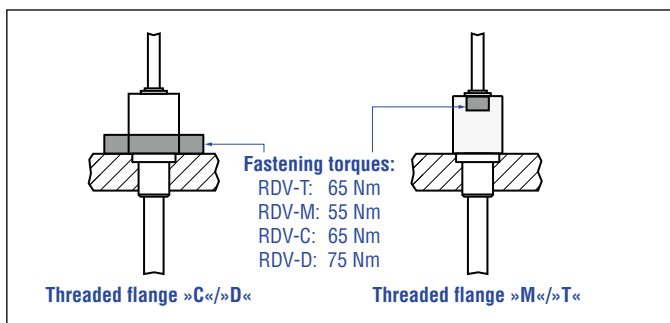

Fig. 37: Mounting example of threaded flange »C«/»D«, »M«/»T«

#### Installation of a rod-style sensor in a fluid cylinder

The rod-style version has been developed for direct stroke measurement in a fluid cylinder. Mount the sensor via threaded flange or a hex nut.

- Mounted on the face of the piston, the position magnet travels over the rod without touching it and indicates the exact position through the rod wall – independent of the hydraulic fluid.
- The pressure resistant sensor rod is installed into a bore in the piston rod.

#### Hydraulics sealing

There are two ways to seal the flange contact (Fig. 38):

1. Sealing via an O-ring (e.g. 22.4 × 2.65 mm, 25.07 × 2.62 mm) in a cylinder end cap groove (for threaded flange »C«/»D«)
2. Sealing via an O-ring 16.4 × 2.2 mm (part no. 560 315) in the flange undercut.

For threaded flange (¾"-16 UNF-3A) »D«/»T«:

O-ring 16.4 × 2.2 mm (0.65 × 0.09 in.) (part no. 560 315)

For threaded flange (M18×1.5-6g) »C«/»M«:

O-ring 15.3 × 2.2 mm (0.60 × 0.09 in.) (part no. 401 133)

In the case of threaded flange M18×1.5-6g provide a screw hole based on ISO 6149-1 (Fig. 39). See ISO 6149-1 for further information.

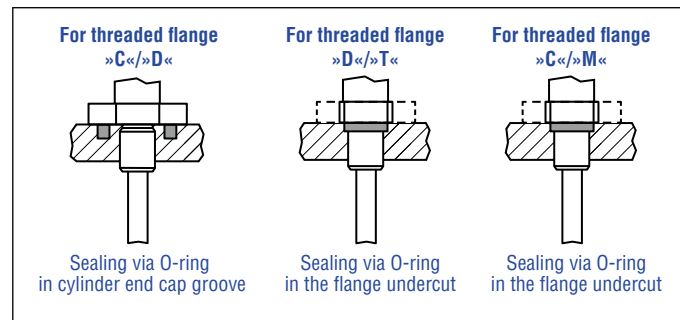

Fig. 38: Possibilities of sealing

- Seat the flange contact surface completely on the cylinder mounting surface.
- The cylinder manufacturer determines the pressure-resistant gasket (copper gasket, O-ring, etc.).
- The position magnet should not grind on the sensor rod.
- The piston rod drilling ( $\geq \varnothing 13$  mm ( $\geq \varnothing 0.51$  in.)) depends on the pressure and piston speed.
- Adhere to the information relating to operating pressure.
- Protect the sensor rod against wear.

Controlling design dimensions are in millimeters and measurements in ( ) are in inches

Notice for metric threaded flanges									
Thread (d <sub>1</sub> × P)	d <sub>2</sub>	d <sub>3</sub>	d <sub>4</sub>	d <sub>5</sub> +0.1 0	L <sub>1</sub> +0.4 0	L <sub>2</sub>	L <sub>3</sub>	L <sub>4</sub>	Z° ±1°
<b>RDV-C</b>									
M18×1.5	55	≥ 13	24.5	19.8	2.4	28.5	2	26	15°
<b>RDV-M</b>									
M18×1.5	30	≥ 13	24.5	19.8	2.4	28.5	2	26	15°

Controlling design dimensions are in millimeters

Fig. 39: Notice for metric threaded flange M18×1.5-6g based on DIN ISO 6149-1

#### 4.7.2. Installation of RD with pressure fit flange

##### Cylinder mounting

Install the rod using the pressure fit flange. Seal it off by means of the O-ring and the back-up ring. Block the pressure fit flange using a shoulder screw (Fig. 40). For details of the pressure fit flange »S« see Fig. 41. Also note the mounting examples in Fig. 42 and Fig. 43.

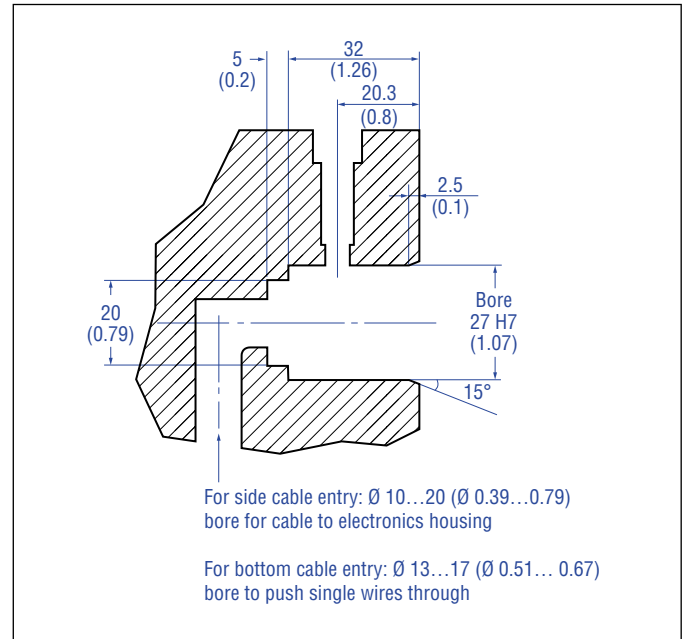

Fig. 40: Example of mounting detail: Shoulder screw 8-M6 (ISO 7379) with internal hexagon

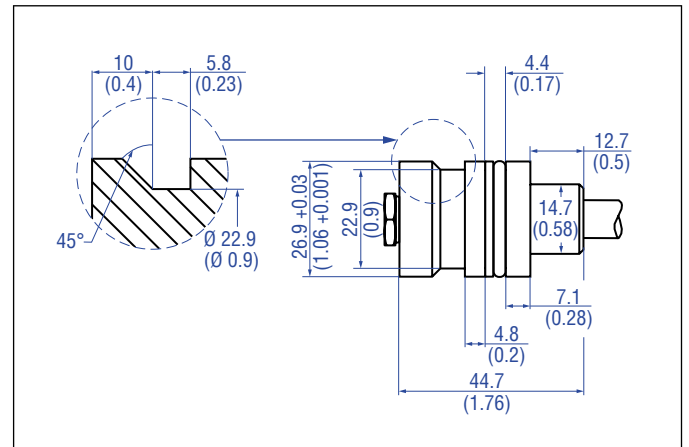

Fig. 41: Pressure fit flange »S« details

##### Note for cylinder installation:

- The position magnet should not grind on the sensor rod.
- The piston rod drilling ( $\geq \text{Ø } 13 \text{ mm}$  ( $\geq \text{Ø } 0.51 \text{ in.}$ )) depends on the pressure and piston speed.
- Adhere to the information relating to operating pressure.
- Protect the sensor rod against wear.

#### 4.7.3. Installation of RDV's sensor electronics housing

The following section explains the connection of an RDV sensor with bottom cable entry (Fig. 42) and side cable entry (Fig. 43) based on RDV-S. The sensor electronics of RDV sensors with threaded flange are mounted in the same way.

##### Sensor electronics with bottom cable entry

Connect the rod via the connector to the sensor electronics. Mount the sensor electronics so that you can lead the cables below the bottom of the housing. Thus the sensor system including the connection cables is fully encapsulated and protected against external disturbances (Fig. 42). Note the bending radius of the cable if you run the cable between sensor electronics and rod (see Fig. 36).

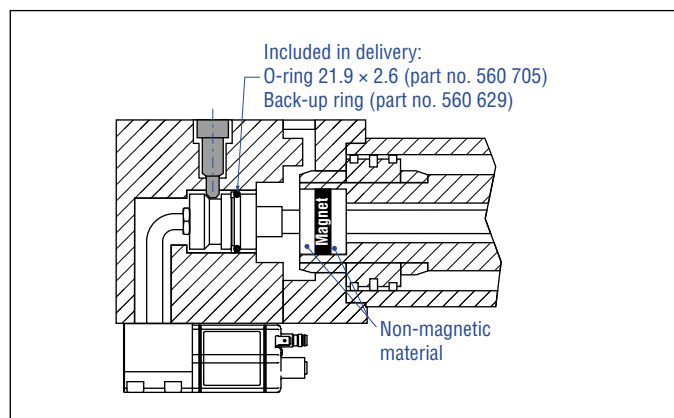

Fig. 42: Mounting example of pressure fit flange »S« and sensor electronics with bottom cable entry

##### Sensor electronics with side cable entry

Connect the rod via the cable to the sensor electronics on the side. Encapsulate the sensor system including the connection cables (Fig. 43). Note the bending radius of the cable if you run the cable between sensor electronics and rod (see Fig. 36).

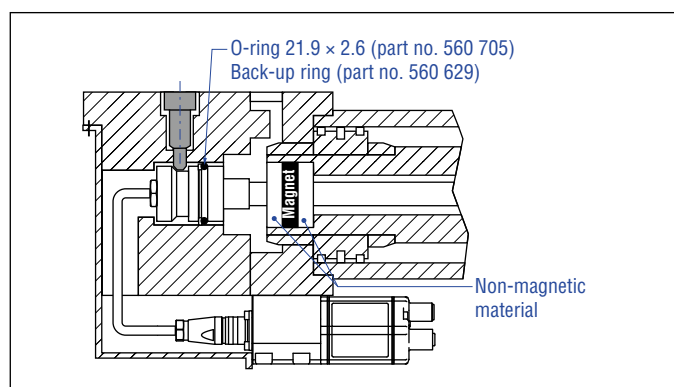

Fig. 43: Mounting example of pressure fit flange »S« and sensor electronics with side cable entry

#### NOTICE

To fulfill the requirements of EMC standards for emission and immunity the following points are necessary:

- The sensor electronics housing has to be connected to machine ground (Fig. 74).
- The cable between the sensor and the electronics must be integrated into a metallic housing.

Connect the flange to the sensor electronics housing via the molex connectors for bottom cable entry respectively via the 6 pin cable for side cable entry.

#### 4.7.4. Mounting of sensor electronics housing

Mount the sensor electronics housing with 4 × M6×45 (ISO 4762) screws via the mounting block. Note the fastening torque of 6 Nm.

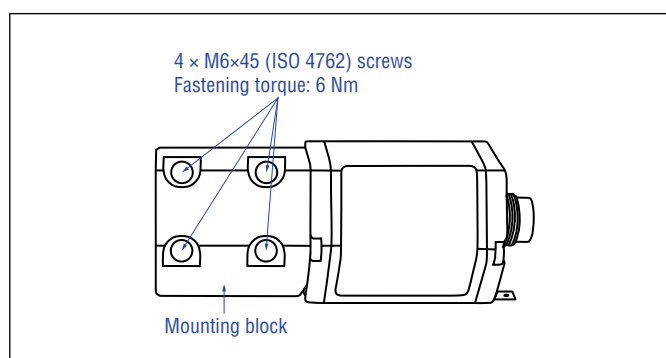

Fig. 44: Mounting of RDV sensor electronics housing (example of bottom cable entry)

## 4.8 Magnet installation

### Typical use of magnets





Magnet	Typical sensors	Benefits
 <b>Ring magnets</b>	<b>Rod model</b> (RH5, RM5, RF5, RFV, RDV)	<ul style="list-style-type: none"> <li>Rotationally symmetrical magnetic field</li> </ul>
 <b>U-magnets</b>	<b>Profile &amp; rod models</b> (RP5, RH5, RM5, RF5, RFV, RDV)	<ul style="list-style-type: none"> <li>Height tolerances can be compensated, because the magnet can be lifted off</li> </ul>
 <b>Block magnets</b>	<b>Profile &amp; rod models</b> (RP5, RH5, RM5, RF5, RFV, RDV)	<ul style="list-style-type: none"> <li>Height tolerances can be compensated, because the magnet can be lifted off</li> </ul>
 <b>Magnet sliders</b>	<b>Profile models</b> (RP5)	<ul style="list-style-type: none"> <li>The magnet is guided by the profile</li> <li>The distance between the magnet and the waveguide is strictly defined</li> <li>Easy coupling via the ball joint</li> </ul>

Fig. 45: Typical use of magnets

### Mounting ring magnets, U-magnets & block magnets

Install the magnet using non-magnetic material for mounting device, screws, spacers etc.. The magnet must not grind on the sensor rod. Alignment errors are compensated via the air gap.

- Permissible surface pressure: Max. 40 N/mm<sup>2</sup> (only for ring magnets and U-magnets)
- Fastening torque for M4 screws: 1 Nm; use washers, if necessary
- Minimum distance between position magnet and any magnetic material has to be 15 mm (0.6 in.) (Fig. 48)
- If no other option exists and magnetic material is used, observe the specified dimensions (Fig. 48)

### NOTICE

- Mount ring magnets and U-magnets concentrically.
- Mount block magnets centrally over the sensor rod or the sensor profile.
- The maximum permissible air gap must not be exceeded (Fig. 46/Fig. 47). Take care to mount the primary sensor axis in parallel to the magnet path in order to avoid damage to the carriage, magnet and sensor rod/sensor profile.

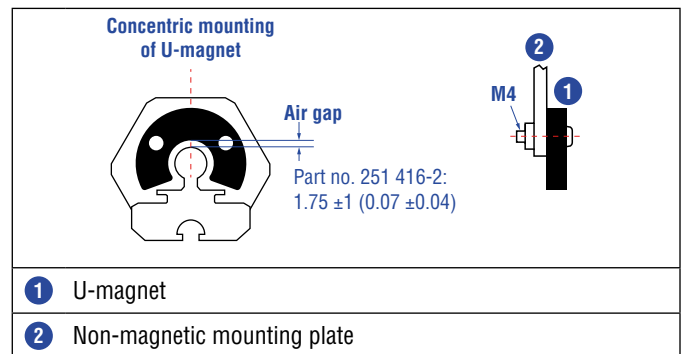

Fig. 46: Mounting of U-magnet (part no. 251 416-2)

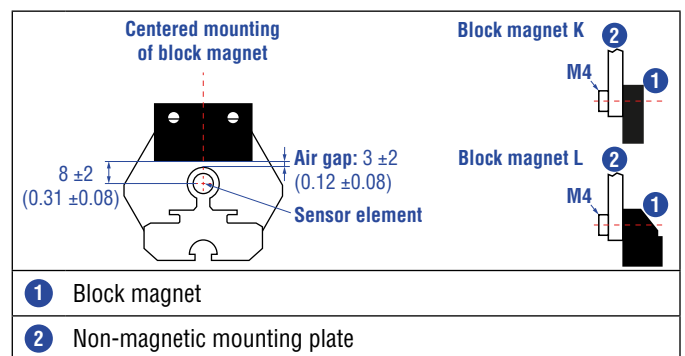

Fig. 47: Mounting of block magnet (part no. 403 448)

### Magnet mounting with magnetic material

When using magnetic material the dimensions of Fig. 48 must be observed.

- If the position magnet aligns with the drilled piston rod
- If the position magnet is set further into the drilled piston rod, install another non-magnetic spacer (e.g. part no. 400 633) above the magnet.

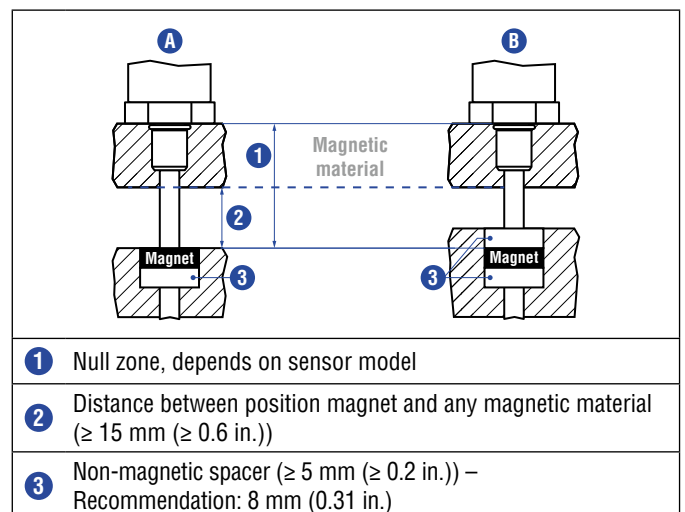

Fig. 48: Installation with magnetic material

**Rod sensors with stroke lengths  $\geq 1$  meter (3.3 ft.)**

Support horizontally installed rod sensors with a stroke length of 1 meter and more (3.3 ft.) mechanically. Without using a support, the sensor rod bends over and the rod and the position magnet may be damaged. A false measurement result is also possible. Longer rods require evenly distributed mechanical support over the entire length (e.g. part no. 561 481). Use an U-magnet (Fig. 49) for measurement.

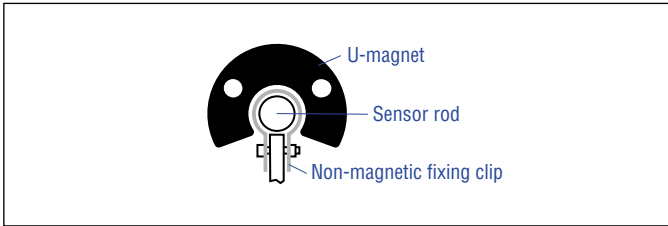

Fig. 49: Example of sensor support with the fixing clip (part no. 561 481)

**Start- and end positions of the position magnets**

Consider the start and end positions of the position magnets during the installation. To ensure that the entire stroke length is electrically usable, the position magnet must be mechanically mounted as follows.

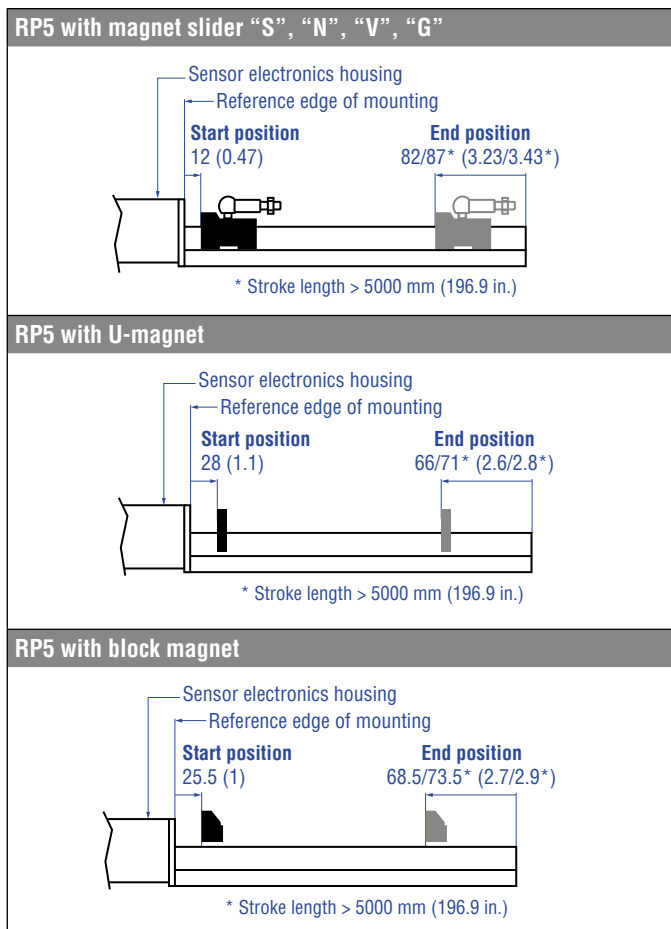

Fig. 50: Start- and end positions of magnets for RP5

Controlling design dimensions are in millimeters and measurements in ( ) are in inches

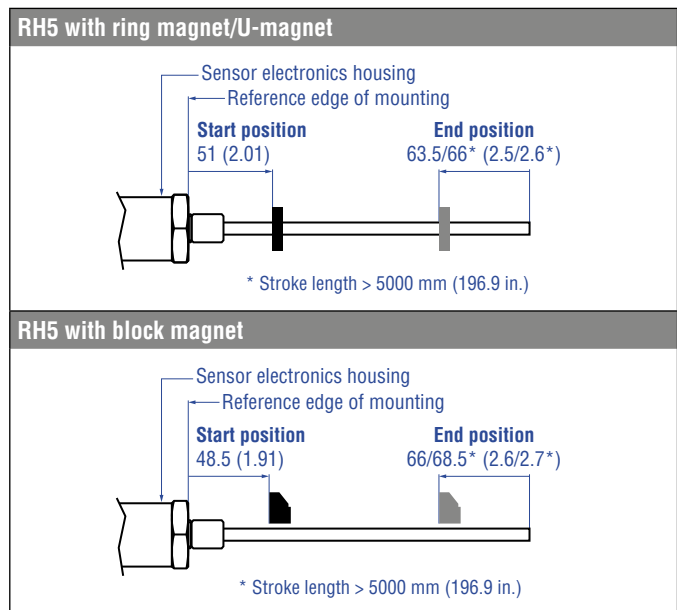

Fig. 51: Start- and end positions of magnets for RH5

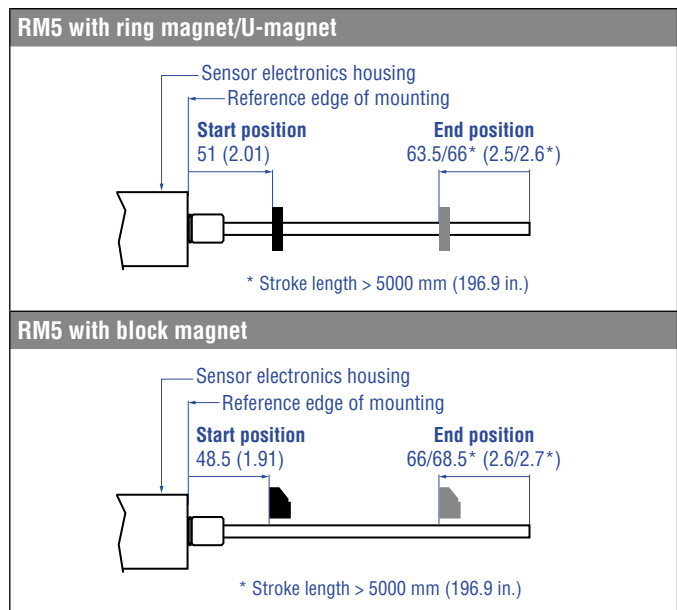

Fig. 52: Start- and end positions of magnets for RM5

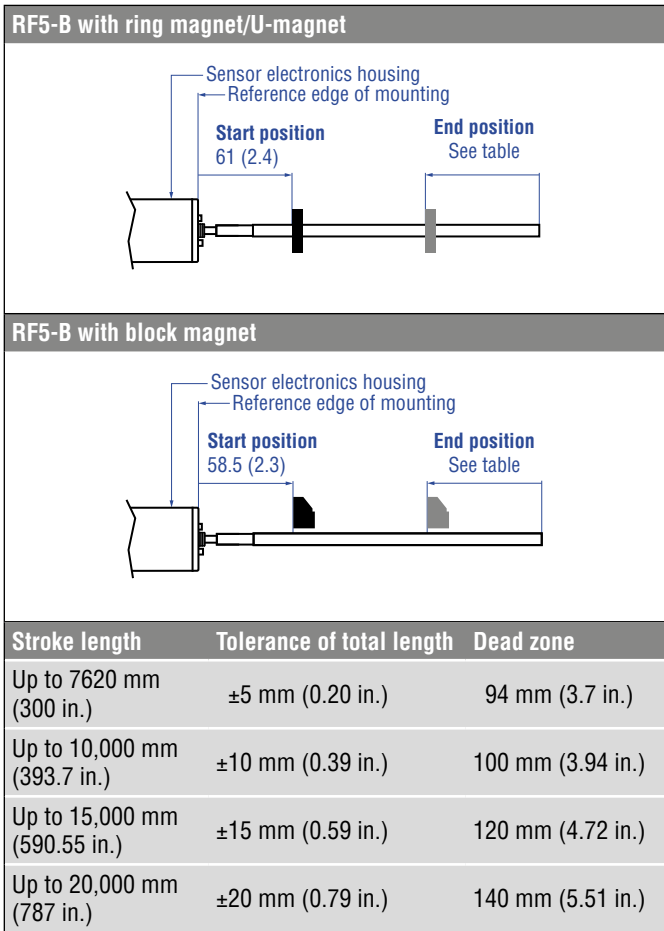

Fig. 53: Start- and end positions of magnets for RF5

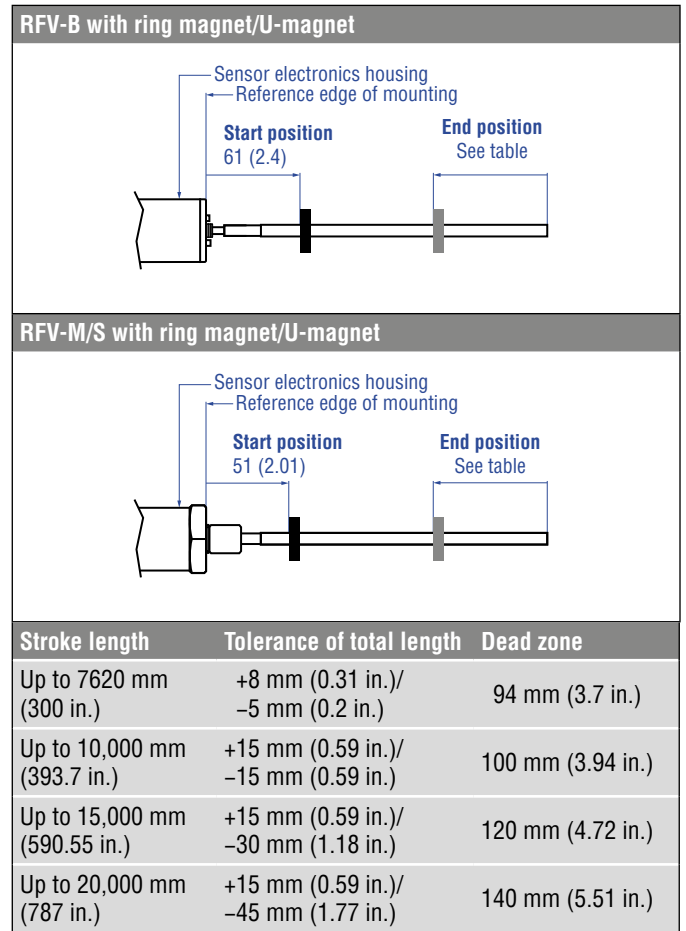

Fig. 54: Start- and end positions of magnets for RFV with ring- and U-magnets

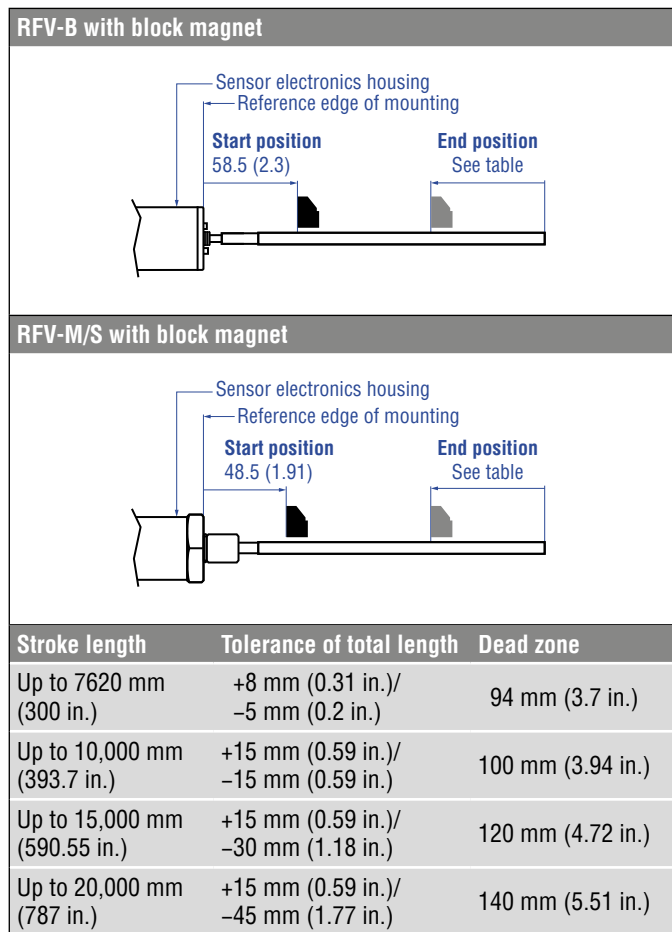

Fig. 55: Start- and end positions of magnets RFV with block magnets

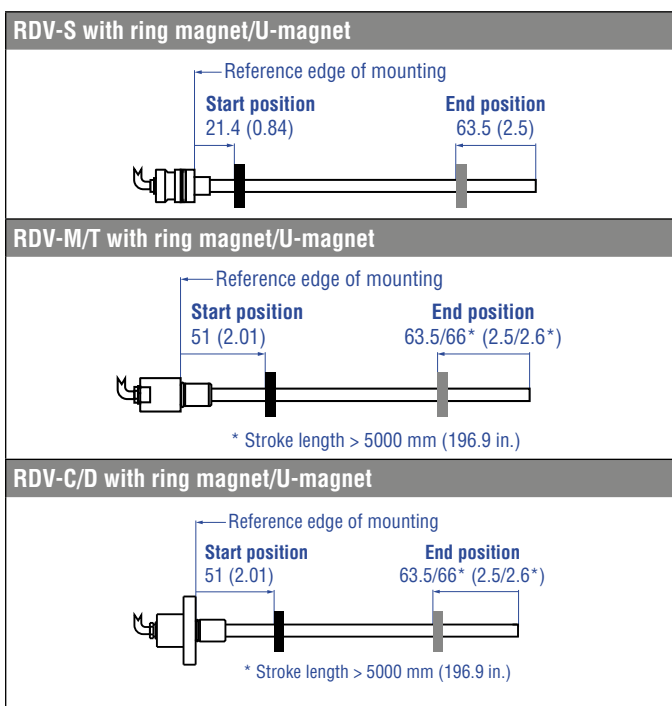

Fig. 56: Start- and end positions of magnets RDV with ring- and U-magnets

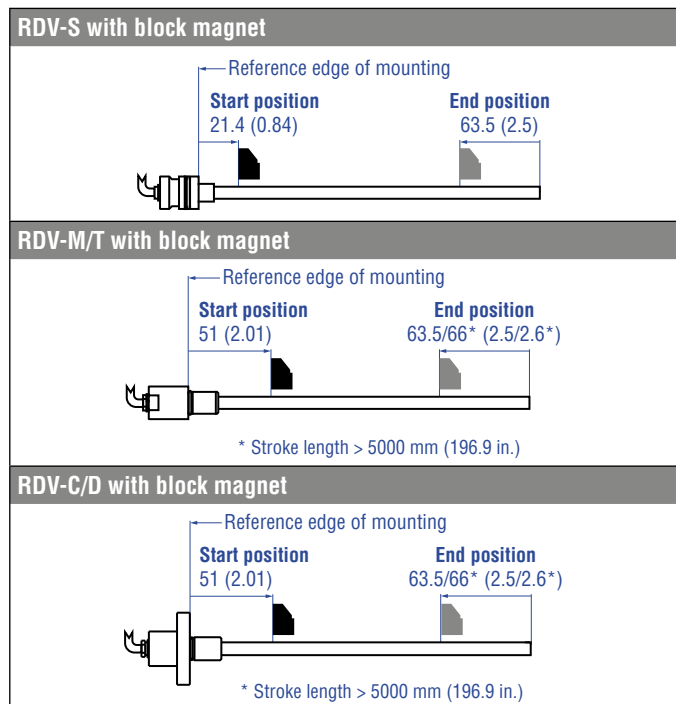

Fig. 57: Start- and end positions of magnets RDV with block magnets

**NOTICE**

On all sensors, the areas left and right of the active stroke length are provided for null and dead zone. These zones should not be used for measurement, however the active stroke length can be exceeded.

Controlling design dimensions are in millimeters and measurements in ( ) are in inches

**Multi-position measurement**

The minimum distance between the magnets is 75 mm (3 in.).

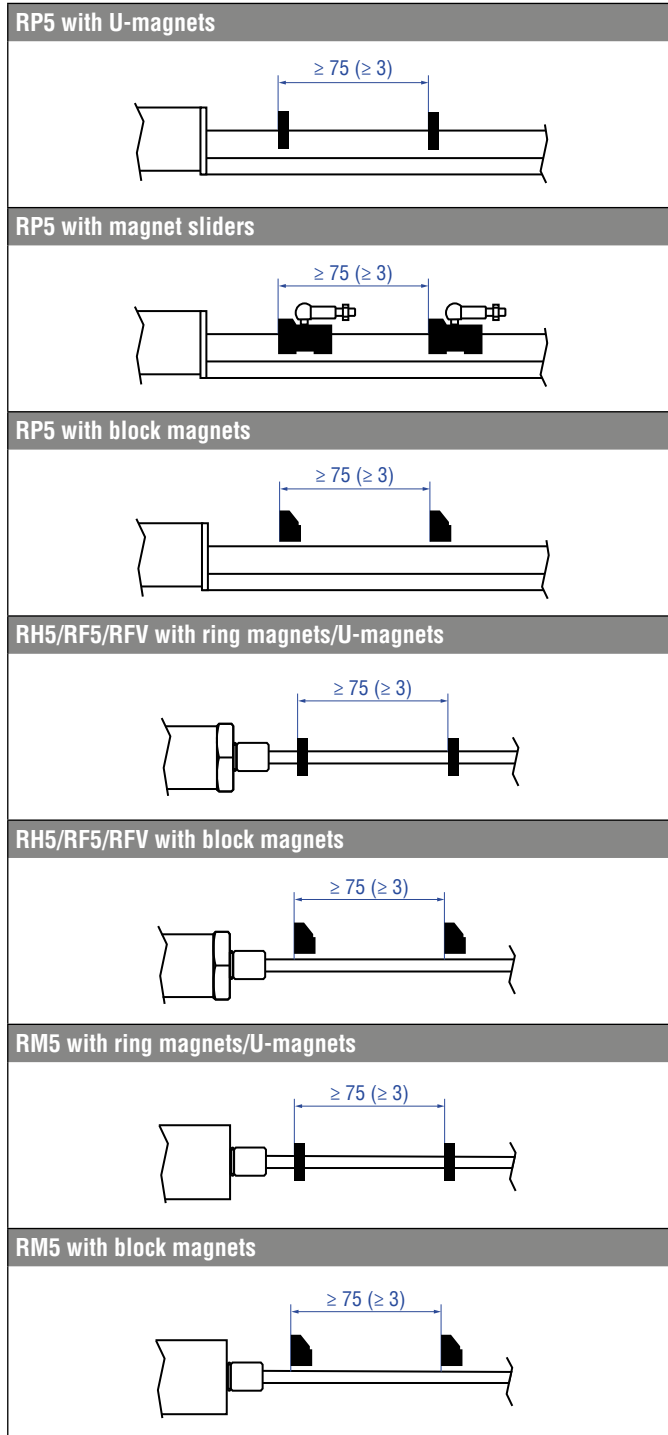

Fig. 58: Minimum distance for multi-position measurement (RP5, RH5, RF5, RFV, RM5)

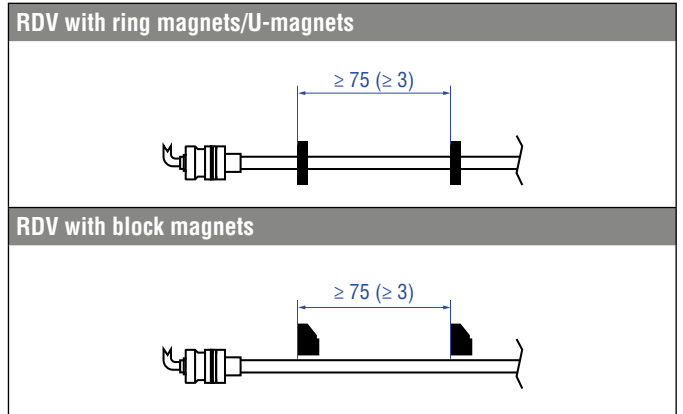

Fig. 59: Minimum distance for multi-position measurement (RDV)

**NOTICE**  
Use magnets of the same type for multi-position measurement. Do not fall below the minimum distance between the magnets of 75 mm (3 in.) for multi-position measurement. Contact Temposonics if you need a magnet distance < 75 mm (3 in.).

#### 4.9 Alignment of the magnet with the option “Internal linearization”

The internal linearization offers improved linearity of the sensor. The option must be specified in the order code of the sensor. The internal linearization is set for the sensor during production.

A sensor with internal linearization is delivered with the magnet with which the sensor was squared during production. In order to achieve the best possible result, Temposonics recommends to operate the sensor with the supplied magnet.

For the internal linearization, the following magnets can be used:

- Ring magnet OD33 (part no. 253 620), for RH5 & RDV only
- U-magnet OD33 (part no. 254 226)
- Ring magnet OD25.4 (part no. 253 621), for RH5 & RDV only
- Magnet slider S (part no. 252 182), for RP5 only
- Magnet slider N (part no. 252 183), for RP5 only
- Magnet slider V (part no. 252 184), for RP5 only
- Magnet slider G (part no. 253 421), for RP5 only

The ring magnet and U-magnet will be marked for the internal linearization. During the installation, the magnets have to be aligned to the sensor electronics housing or the flange of the RDV (see Fig. 60, Fig. 61, Fig. 62, Fig. 63 and Fig. 64).

#### For RH5 POWERLINK sensors with ring magnet/U-magnet applies:

- Install the magnet until the marking on the magnet points to the sensor electronics housing.
- The marking on the magnet points to the same direction as the elongated status LED in the lid of the sensor electronics housing.

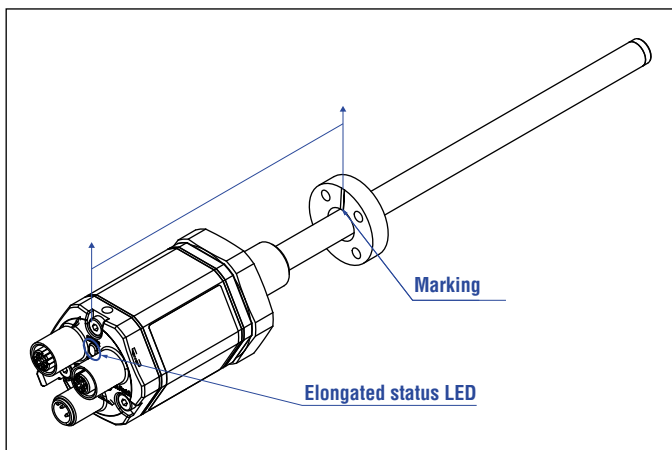

Fig. 60: Magnet alignment of ring magnet for RH5 POWERLINK with internal linearization

#### For RP5 POWERLINK sensors with U-magnet applies:

- Install the magnet until the marking on the magnet points to the sensor electronics housing.
- The marking on the magnet points to the same direction as the elongated status LED in the lid of the sensor electronics housing.

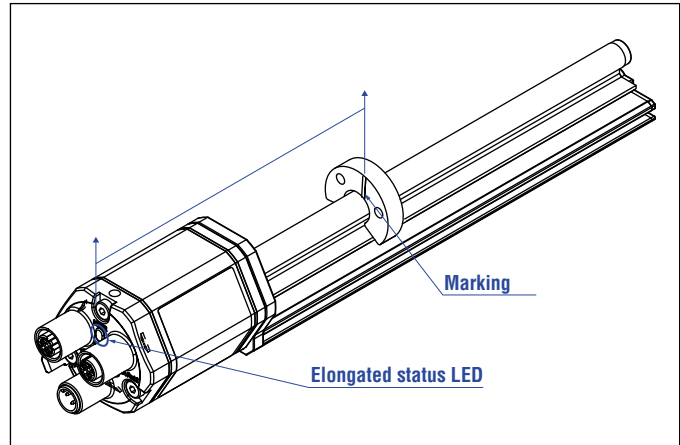

Fig. 61: Magnet alignment of U-magnet for RP5 POWERLINK with internal linearization

#### For RP5 POWERLINK sensors with magnet slider applies:

- 1 Install the magnet sliders “S”, “N” and “G” until the additional hole in the magnet points towards the sensor electronics housing.
- 2 Install the magnet slider “V” until the joint points to the end of the profile.

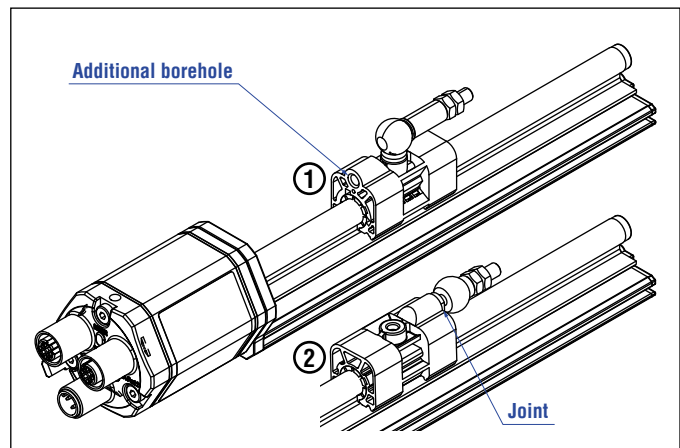

Fig. 62: Magnet alignment of magnet slider for RP5 POWERLINK with internal linearization

**For RDV POWERLINK sensors with ring magnet/U-magnet applies:**

- Install the magnet so that the marking on the magnet faces the sensor flange.
- The marking on the magnet points in the same direction as the marking on the sensor flange.

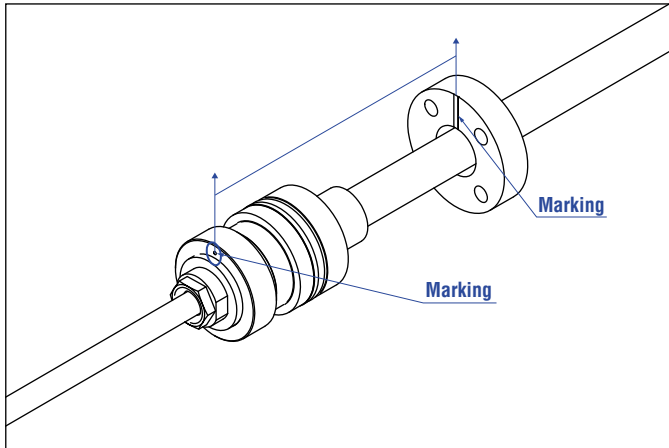

Fig. 63: Magnet alignment of magnet slider for RDV POWERLINK with internal linearization using the example of a »S« flange

**For RM5 POWERLINK sensors with ring magnet/U-magnet applies:**

- Install the magnet so that the marking on the magnet faces the super shield housing.
- The line on the magnet points in the same direction as the marking on the super shield housing.

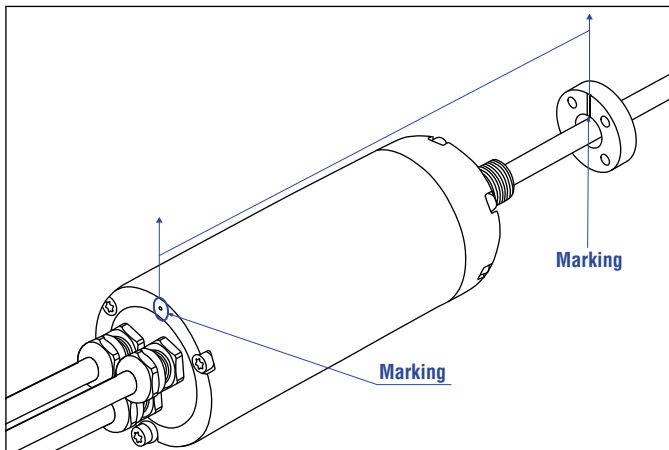

Fig. 64: Magnet alignment of magnet slider for RM5 POWERLINK with internal linearization

**The internal linearization of the sensor is carried out under the following conditions:**

- Supply voltage +24 VDC  $\pm$  0.5
- Operating time > 30 min
- No shock and no vibration
- Eccentricity of the position magnet to central axis of the sensor < 0.1 mm

**NOTICE**

The generated linearization might deviate from the linearity tolerances regarding different environmental conditions. In addition, the use of a different position magnet or more position magnets may cause differences.

## 4.10 Replacement of base unit

### 4.10.1. Replacement of base unit on the RH5/RFV/RF5 model

The base unit of the sensor model RH5 (RH5-B) is replaceable as shown in Fig. 65 and Fig. 66 for the sensor designs »M«, »S« and »T«. The sensor can be replaced without interrupting the hydraulic circuit. This also applies to the RFV-B/RF5-B sensor, which is installed in the optional HD, HL and HP sensor rod.

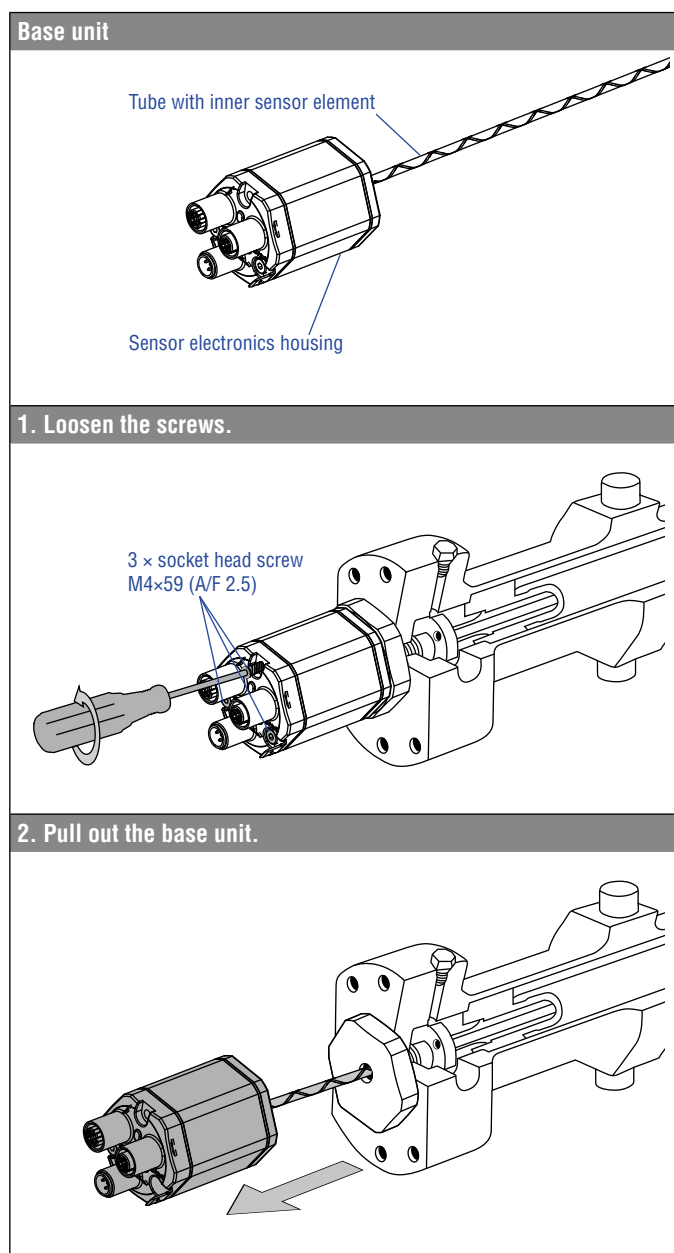

Fig. 65: Replacement of the base unit (e.g. RH5 sensor), part 1

3. Insert the new base unit.  
Mount the ground lug on a screw.  
Tighten the screws.

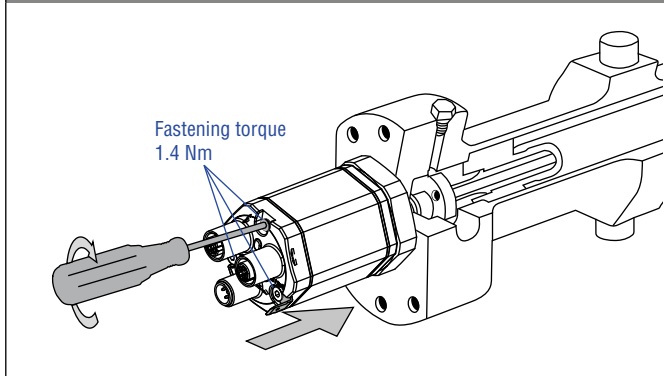

Fig. 66: Replacement of the base unit (e.g. RH5 sensor), part 2

#### NOTICE

- When replacing the base unit, make sure that no humidity enters the sensor tube. This may damage the sensor.
- Secure the base unit screws, e.g. using Loctite 243, before re-installing.
- If the R-Series V replaces a predecessor model of the R-Series, the plastic tube in the sensor rod must be removed.
- Make sure the O-ring (part no. 562 003) is correctly fitted between the flange and the base unit.
- The O-ring is secured with an adhesive strip. Remove the adhesive strip before tightening before reinstalling the base unit (see illustration "Remove adhesive strips").

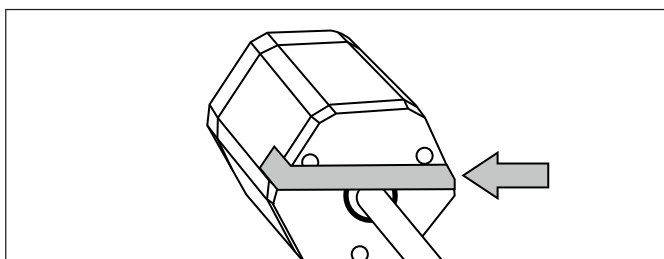

Fig. 67: Remove adhesive strips

Remove the transport cap at the end of the flexible sensor element before installing an RH5-B-F (Fig. 68). Slowly push the flexible sensor element into the sensor rod so that the air inside the rod can escape. Observe the minimum bending radius of 100 mm and the instructions for handling and installing an RF5 in chapter 4.5.

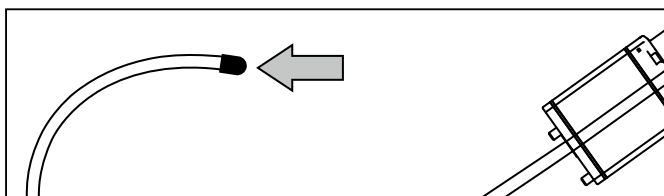

Fig. 68: Remove the transport cap from the RH5-B-F before installation

#### 4.10.2. Replacement of base unit on the RM5 model

A base unit RM5-B is installed in the super shield housing of the RM5 (Fig. 69). The base unit can be replaced without interrupting the hydraulic circuit.

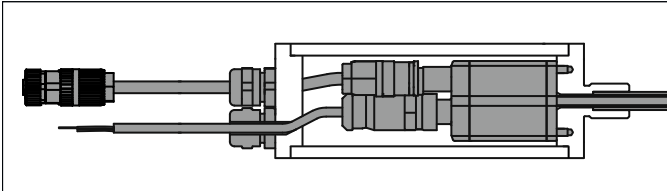

Fig. 69: Base unit in the super shield housing of the RM5

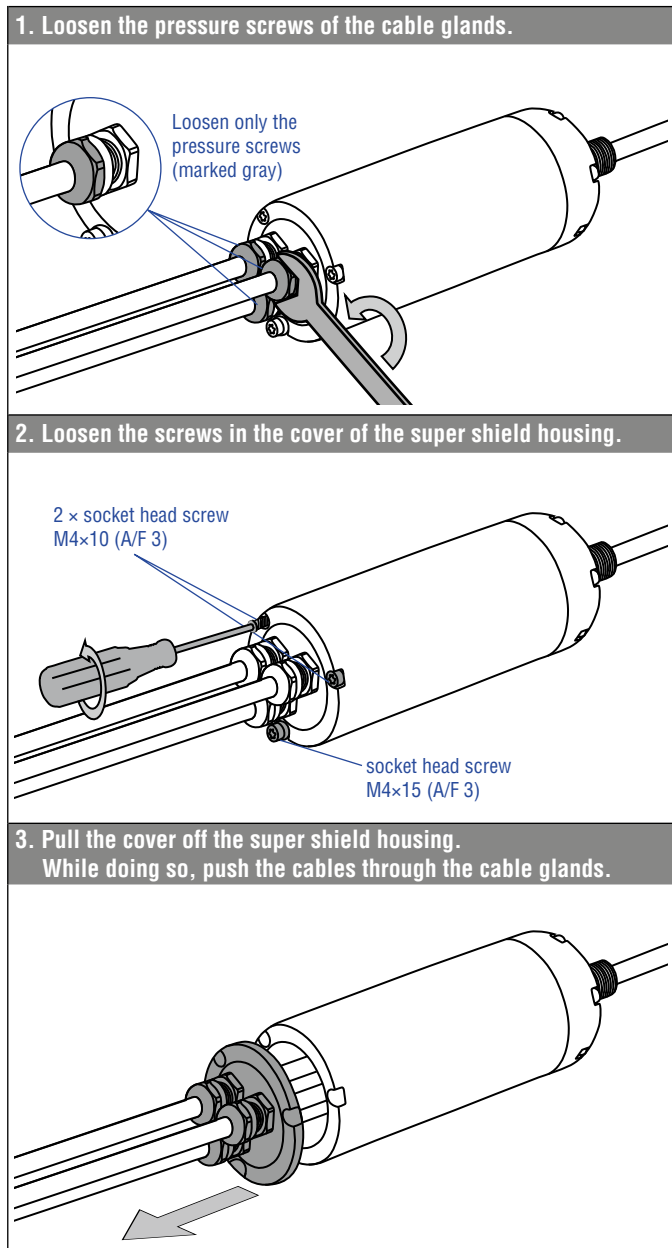

Fig. 70: Replacement of the base unit on model RM5, part 1

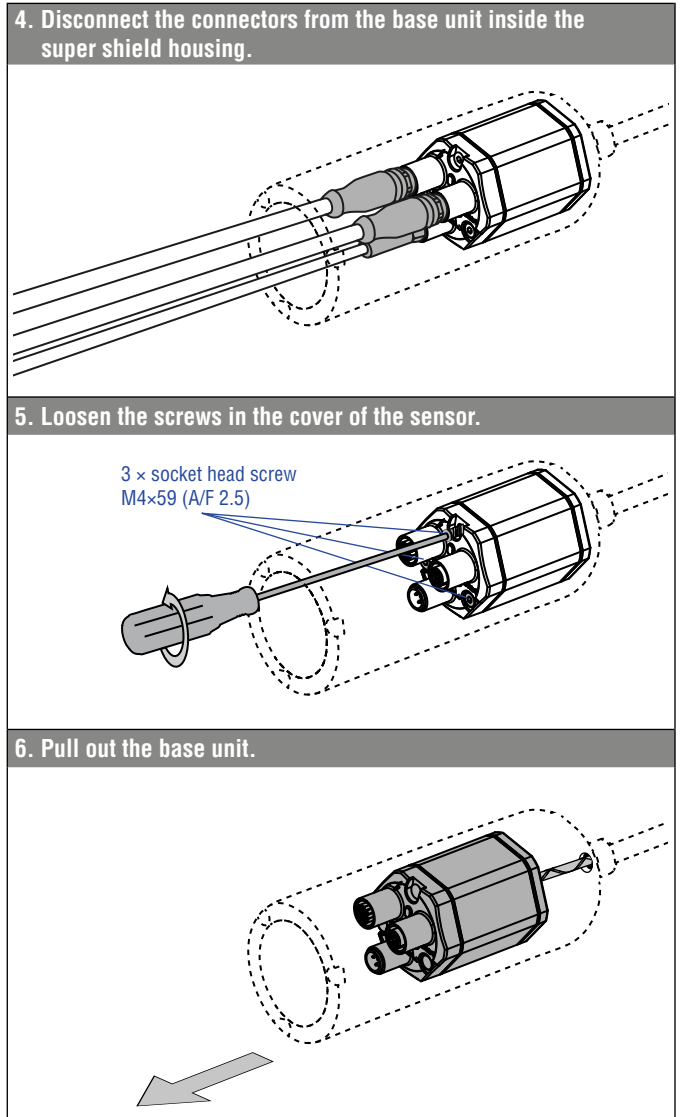
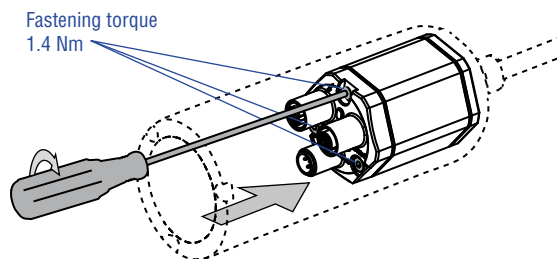

Fig. 71: Replacement of the base unit on model RM5, part 2

Continued on next page

7. Insert the new base unit.  
Screw the base unit tight.  
Secure the screws of the base unit before re-installing,  
e.g. with Loctite 243.



8. Attach the connectors to the base unit in the super shield housing.

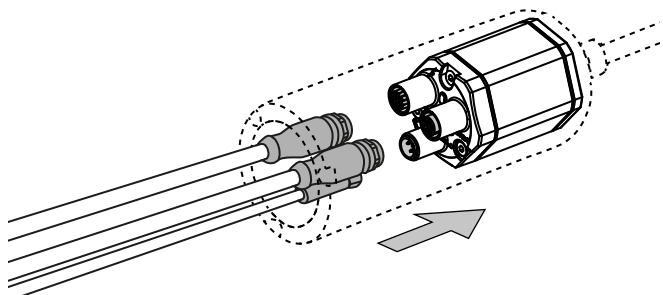

9. Place the lid on the super shield housing.  
Screw the lid tight.  
Secure the screws of the lid before reassembly,  
e.g. with Loctite 243.

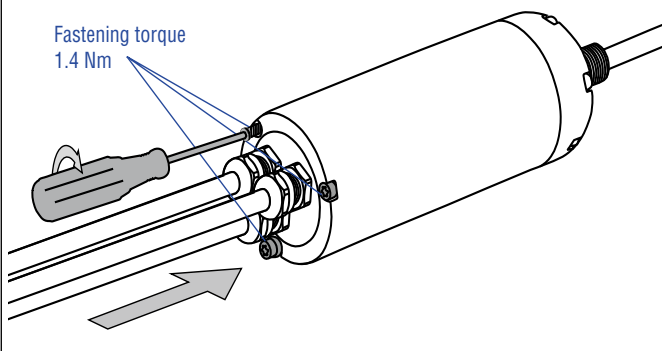

Fig. 72: Replacement of the base unit on model RM5, part 3

10. Carefully pull the excess cables out of the super shield housing. Tighten the pressure screw (marked gray) of the cable glands until the sealing insert and pressure screw are at the same height.  
Secure the cable glands before reassembly, e.g. with Loctite 243.

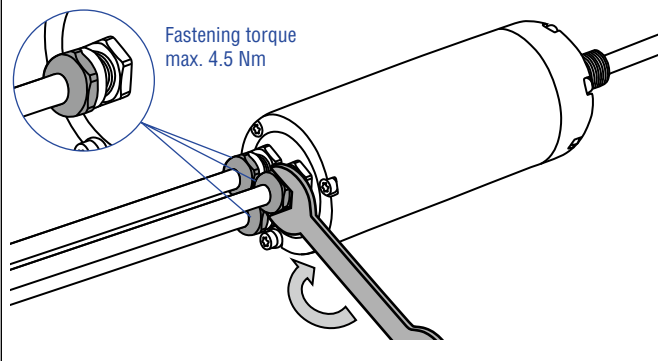

Fig. 73: Replacement of the base unit on model RM5, part 4

**NOTICE**

When replacing the base unit, make sure that no humidity enters the sensor tube. This may damage the sensor.

#### 4.11 Electrical connection

Placement of installation and cabling have decisive influence on the sensor's electromagnetic compatibility (EMC). Hence correct installation of this active electronic system and the EMC of the entire system must be ensured by using suitable metal connectors, shielded cables and grounding. Overvoltages or faulty connections can damage its electronics despite protection against wrong polarity.

#### NOTICE

1. Do not mount the sensors in the area of strong magnetic or electric noise fields.
2. Never connect/disconnect the sensor when voltage is applied.

#### Instructions for connection

- Use low-resistant twisted pair and shielded cables. Connect the shield to ground externally via the controller equipment.
- Keep control and signal cables separate from power cables and sufficiently far away from motor cables, frequency inverters, valve lines, relays, etc..
- Use only connectors with metal housing and connect the shielding to the connector housing.
- Keep the connection surface at both shielding ends as large as possible. Connect the cable clamps to function as a ground.
- Keep all non-shielded leads as short as possible.
- Keep the earth connection as short as possible with a large cross section. Avoid ground loops.
- With potential differences between machine and electronics earth connections, no compensating currents are allowed to flow across the cable shielding.

#### Recommendation:

Install potential compensating leads with large cross section, or use cables with separate double shielding, and connect only one end of the shield.

- Use only stabilized power supplies in compliance with the specified electrical ratings.

#### Grounding of profile and rod sensors

Connect the sensor electronics housing to machine ground. Ground R-Series V sensors via ground lug as shown in Fig. 74. Note the installation example for grounding an RM5 sensor in Fig. 75. In addition you can ground the sensor types RH5, RM5 and RFV via thread.

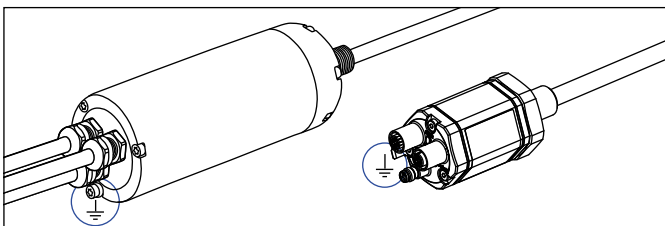

Fig. 74: Grounding via ground lug on the example of an RM5 sensor (left)/RH5 sensor (right)

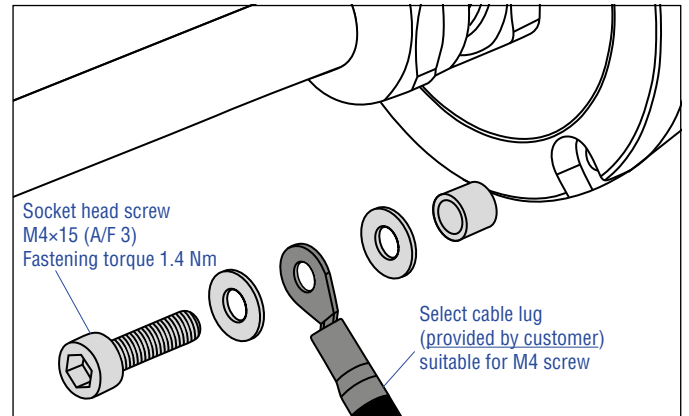

Fig. 75: Installation example for grounding of RM5 sensor

#### NOTICE

Secure the socket head screw before reassembly, e.g. with Loctite 243.

#### Connector wiring

Connect the sensor directly to the control system, indicator or other evaluating systems as follows:

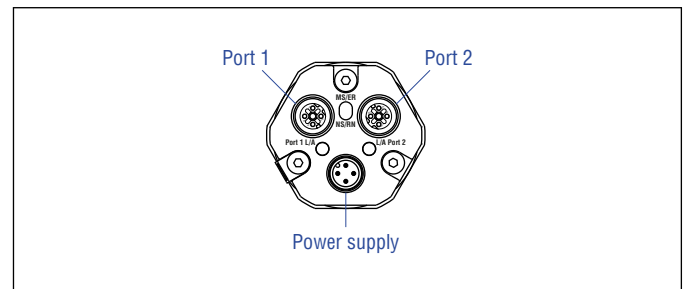

Fig. 76: Location of connections



D56		
<b>Port 1 – Signal</b>		
<b>M12 female connector (D-coded)</b>	<b>Pin</b>	<b>Function</b>
 <p>View on sensor</p>	1	Tx (+)
	2	Rx (+)
	3	Tx (-)
	4	Rx (-)
<b>Port 2 – Signal</b>		
<b>M12 female connector (D-coded)</b>	<b>Pin</b>	<b>Function</b>
 <p>View on sensor</p>	1	Tx (+)
	2	Rx (+)
	3	Tx (-)
	4	Rx (-)
<b>Power supply</b>		
<b>M8 male connector</b>	<b>Pin</b>	<b>Function</b>
 <p>View on sensor</p>	1	+12...30 VDC ( $\pm 20\%$ )
	2	Not connected
	3	DC Ground (0 V)
	4	Not connected

Fig. 77: Connector wiring D56



D58		
<b>Port 1 – Signal</b>		
<b>M12 female connector (D-coded)</b>	<b>Pin</b>	<b>Function</b>
 <p>View on sensor</p>	1	Tx (+)
	2	Rx (+)
	3	Tx (-)
	4	Rx (-)
<b>Port 2 – Signal</b>		
<b>M12 female connector (D-coded)</b>	<b>Pin</b>	<b>Function</b>
 <p>View on sensor</p>	1	Tx (+)
	2	Rx (+)
	3	Tx (-)
	4	Rx (-)
<b>Power supply</b>		
<b>M12 male connector (A-coded)</b>	<b>Pin</b>	<b>Function</b>
 <p>View on sensor</p>	1	+12...30 VDC ( $\pm 20\%$ )
	2	Not connected
	3	DC Ground (0 V)
	4	Not connected

Fig. 78: Connector wiring D58



MXX		
<b>Port 1 – Signal</b>		
<b>M12 female connector (D-coded)</b>	<b>Pin</b>	<b>Function</b>
 <p>View on sensor</p>	1	Tx (+)
	2	Rx (+)
	3	Tx (-)
	4	Rx (-)
<b>Port 2 – Signal</b>		
<b>M12 female connector (D-coded)</b>	<b>Pin</b>	<b>Function</b>
 <p>View on sensor</p>	1	Tx (+)
	2	Rx (+)
	3	Tx (-)
	4	Rx (-)
<b>Power supply</b>		
<b>Cable</b>	<b>Color</b>	<b>Function</b>
	BN	+12...30 VDC (±20 %)
	WH	Not connected
	BU	DC Ground (0 V)
	BK	Not connected

Fig. 79: Connector wiring MXX

4.12 Frequently ordered accessories for Temposonics® RP5 – Additional options see [Accessories Catalog](#) 551444

Position magnets

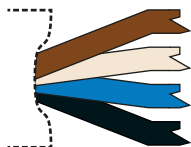
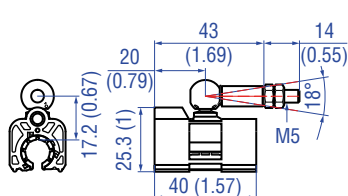

**Magnet slider S,  
joint at top**  
Part no. 252 182

Material: GRP, magnet hard ferrite  
Weight: Approx. 35 g  
Operating temperature:  
-40...+85 °C (-40...+185 °F)

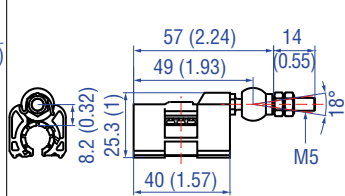

**Magnet slider V,  
joint at front**  
Part no. 252 184

Material: GRP, magnet hard ferrite  
Weight: Approx. 35 g  
Operating temperature:  
-40...+85 °C (-40...+185 °F)

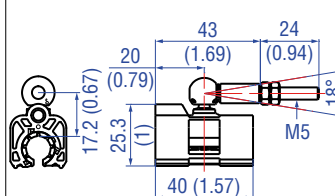

**Magnet slider N  
longer ball-joint arm**  
Part no. 252 183

Material: GRP, magnet hard ferrite  
Weight: Approx. 35 g  
Operating temperature:  
-40...+85 °C (-40...+185 °F)

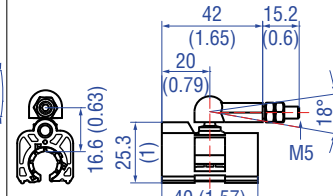

**Magnet slider G,  
backlash free**  
Part no. 253 421

Material: GRP, magnet hard ferrite  
Weight: Approx. 25 g  
Operating temperature:  
-40...+85 °C (-40...+185 °F)

Position magnets

Mounting accessories

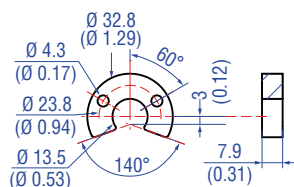

**U-magnet OD33**  
Part no. 251 416-2

Material: PA ferrite GF20  
Weight: Approx. 11 g  
Surface pressure: Max. 40 N/mm<sup>2</sup>  
Fastening torque for M4 screws: 1 Nm  
Operating temperature:  
-40...+120 °C (-40...+248 °F)

Marked version for sensors with internal linearization: Part no. 254 226

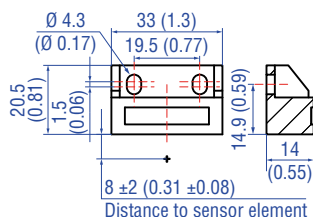

**Block magnet L**  
Part no. 403 448

Material: Plastic carrier with neodymium magnet  
Weight: Approx. 20 g  
Fastening torque for M4 screws: 1 Nm  
Operating temperature:  
-40...+75 °C (-40...+167 °F)

This magnet may influence the sensor performance specifications for some applications.

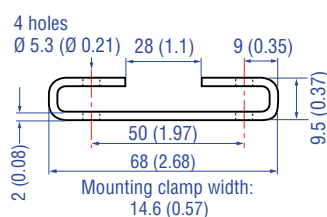

**Mounting clamp**  
Part no. 400 802

Material: Stainless steel (AISI 304)

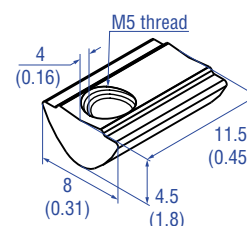

**T-nut**  
Part no. 401 602

Fastening torque for M5 screw: 4.5 Nm

4.13 Frequently ordered accessories for Temposonics® RH5 – Additional options see [Accessories Catalog](#) 551444

Position magnets

<p><b>U-magnet OD33</b> Part no. 251 416-2</p> <p>Material: PA ferrite GF20 Weight: Approx. 11 g Surface pressure: Max. 40 N/mm<sup>2</sup> Fastening torque for M4 screws: 1 Nm Operating temperature: -40...+120 °C (-40...+248 °F) Marked version for sensors with internal linearization: Part no. 254 226</p>	<p><b>Ring magnet OD33</b> Part no. 201 542-2</p> <p>Material: PA ferrite GF20 Weight: Approx. 14 g Surface pressure: Max. 40 N/mm<sup>2</sup> Fastening torque for M4 screws: 1 Nm Operating temperature: -40...+120 °C (-40...+248 °F) Marked version for sensors with internal linearization: Part no. 253 620</p>	<p><b>Ring magnet OD25.4</b> Part no. 400 533</p> <p>Material: PA ferrite Weight: Approx. 10 g Surface pressure: Max. 40 N/mm<sup>2</sup> Operating temperature: -40...+120 °C (-40...+248 °F) Marked version for sensors with internal linearization: Part no. 253 621</p>	<p><b>Ring magnet</b> Part no. 402 316</p> <p>Material: PA ferrite coated Weight: Approx. 13 g Surface pressure: Max. 20 N/mm<sup>2</sup> Operating temperature: -40...+100 °C (-40...+212 °F)</p>

Position magnet      Magnet spacer      O-rings

<p><b>Block magnet L</b> Part no. 403 448</p> <p>Material: Plastic carrier with neodymium magnet Weight: Approx. 20 g Fastening torque for M4 screws: 1 Nm Operating temperature: -40...+75 °C (-40...+167 °F)</p> <p>This magnet may influence the sensor performance specifications for some applications.</p>	<p><b>Magnet spacer</b> Part no. 400 633</p> <p>Material: Aluminum Weight: Approx. 5 g Surface pressure: Max. 20 N/mm<sup>2</sup> Fastening torque for M4 screws: 1 Nm</p>	<p><b>O-ring for threaded flange</b> M18x1.5-6g Part no. 401 133</p> <p>Material: Fluoroelastomer Durometer: 75 ± 5 Shore A Operating temperature: -40...+204 °C (-40...+400 °F)</p>	<p><b>O-ring for threaded flange</b> ¾"-16 UNF-3A Part no. 560 315</p> <p>Material: Fluoroelastomer Durometer: 75 ± 5 Shore A Operating temperature: -40...+204 °C (-40...+400 °F)</p>

O-ring      Mounting accessories

<p><b>O-ring for threaded flange</b> M22x1.5-6g Part no. 561 337</p> <p>Material: FPM Durometer: 75 Shore A Operating temperature: -20...+200 °C (-6...+392 °F)</p>	<p><b>Hex jam nut M18x1.5-6g</b> Part no. 500 018</p> <p>Material: Steel, zinc plated</p>	<p><b>Hex jam nut ¾"-16 UNF-3A</b> Part no. 500 015</p> <p>Material: Steel, zinc plated</p>	<p><b>Fixing clip</b> Part no. 561 481</p> <p>Application: Used to secure sensor rods (Ø 10 mm (Ø 0.39 in.)) when using an U-magnet or block magnet Material: Brass, non-magnetic</p>

4.14 Frequently ordered accessories for Temposonics® RM5 – Additional options see [Accessories Catalog](#) 551444

Position magnets

<p><b>U-magnet OD33</b> <b>Part no. 251 416-2</b></p> <p>Material: PA ferrite GF20 Weight: Approx. 11 g Surface pressure: Max. 40 N/mm<sup>2</sup> Fastening torque for M4 screws: 1 Nm Operating temperature: -40...+120 °C (-40...+248 °F)</p> <p>Marked version for sensors with internal linearization: Part no. 254 226</p>	<p><b>Ring magnet OD33</b> <b>Part no. 201 542-2</b></p> <p>Material: PA ferrite GF20 Weight: Approx. 14 g Surface pressure: Max. 40 N/mm<sup>2</sup> Fastening torque for M4 screws: 1 Nm Operating temperature: -40...+120 °C (-40...+248 °F)</p> <p>Marked version for sensors with internal linearization: Part no. 253 620</p>	<p><b>Ring magnet OD25.4</b> <b>Part no. 400 533</b></p> <p>Material: PA ferrite Weight: Approx. 10 g Surface pressure: Max. 40 N/mm<sup>2</sup> Operating temperature: -40...+120 °C (-40...+248 °F)</p> <p>Marked version for sensors with internal linearization: Part no. 253 621</p>	<p><b>Ring magnet</b> <b>Part no. 402 316</b></p> <p>Material: PA ferrite coated Weight: Approx. 13 g Surface pressure: Max. 20 N/mm<sup>2</sup> Operating temperature: -40...+100 °C (-40...+212 °F)</p>

Position magnet

Magnet spacer

O-rings

<p><b>Block magnet L</b> <b>Part no. 403 448</b></p> <p>Material: Plastic carrier with neodymium magnet Weight: Approx. 20 g Fastening torque for M4 screws: 1 Nm Operating temperature: -40...+75 °C (-40...+167 °F)</p> <p>This magnet may influence the sensor performance specifications for some applications.</p>	<p><b>Magnet spacer</b> <b>Part no. 400 633</b></p> <p>Material: Aluminum Weight: Approx. 5 g Surface pressure: Max. 20 N/mm<sup>2</sup> Fastening torque for M4 screws: 1 Nm</p>	<p><b>O-ring for threaded flange</b> <b>M18x1.5-6g</b> <b>Part no. 401 133</b></p> <p>Material: Fluoroelastomer Durometer: 75 ±5 Shore A Operating temperature: -40...+204 °C (-40...+400 °F)</p>	<p><b>O-ring for threaded flange</b> <b>3/4"-16 UNF-3A</b> <b>Part no. 560 315</b></p> <p>Material: Fluoroelastomer Durometer: 75 ±5 Shore A Operating temperature: -40...+204 °C (-40...+400 °F)</p>

Mounting accessories

<p><b>Hex jam nut M18x1.5-6g</b> <b>Part no. 500 018</b></p> <p>Material: Steel, zinc plated</p>	<p><b>Hex jam nut 3/4"-16 UNF-3A</b> <b>Part no. 500 015</b></p> <p>Material: Steel, zinc plated</p>	<p><b>Fixing clip</b> <b>Part no. 561 481</b></p> <p>Application: Used to secure sensor rods (Ø 10 mm (Ø 0.39 in.)) when using an U-magnet or block magnet Material: Brass, non-magnetic</p>

4.15 Frequently ordered accessories for Temposonics® RF5 – Additional options see [Accessories Catalog](#) 551444

Position magnets

<p><b>U-magnet OD33</b> <b>Part no. 251 416-2</b></p> <p>Material: PA ferrite GF20 Weight: Approx. 11 g Surface pressure: Max. 40 N/mm<sup>2</sup> Fastening torque for M4 screws: 1 Nm Operating temperature: -40...+120 °C (-40...+248 °F)</p>	<p><b>Ring magnet OD60</b> <b>Part no. MT0162</b></p> <p>Material: AlCuMgPb, magnets compound-filled Weight: Approx. 90 g Surface pressure: Max. 20 N/mm<sup>2</sup> Fastening torque for M4 screws: 1 Nm Operating temperature: -40...+75 °C (-40...+167 °F)</p>	<p><b>Ring magnet</b> <b>Part no. 402 316</b></p> <p>Material: PA ferrite coated Weight: Approx. 13 g Surface pressure: Max. 20 N/mm<sup>2</sup> Operating temperature: -40...+100 °C (-40...+212 °F)</p>	<p><b>U-magnet OD63.5</b> <b>Part no. 201 553</b></p> <p>Material: PA 66-GF30, magnets compound-filled Weight: Approx. 26 g Surface pressure: 20 N/mm<sup>2</sup> Fastening torque for M4 screws: 1 Nm Operating temperature: -40...+75 °C (-40...+167 °F)</p>

O-rings

Mounting accessories

<p><b>O-ring for threaded flange</b> <b>M18x1.5-6g</b> <b>Part no. 401 133</b></p> <p>Material: Fluoroelastomer Durometer: 75 ±5 Shore A Operating temperature: -40...+204 °C (-40...+400 °F)</p>	<p><b>O-ring for threaded flange</b> <b>¾"-16 UNF-3A</b> <b>Part no. 560 315</b></p> <p>Material: Fluoroelastomer Durometer: 75 ±5 Shore A Operating temperature: -40...+204 °C (-40...+400 °F)</p>	<p><b>Hex jam nut M18x1.5-6g</b> <b>Part no. 500 018</b></p> <p>Material: Steel, zinc plated</p>	<p><b>Hex jam nut ¾"-16 UNF-3A</b> <b>Part no. 500 015</b></p> <p>Material: Steel, zinc plated</p>

Mounting accessories







**Threaded flange M18x1.5-6g**  
**Part no. 404 874**

**Threaded flange ¾"-16 UNF-3A**  
**Part no. 404 875**

Material: Stainless steel 1.4305 (AISI 303)  
Order O-rings separately:  
O-ring 15x2: Part no. 560 853  
O-ring 15.3x2.2: Part no. 401 133

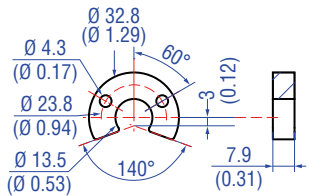
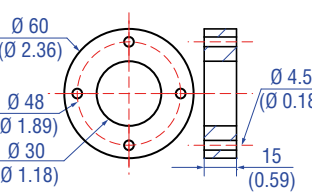
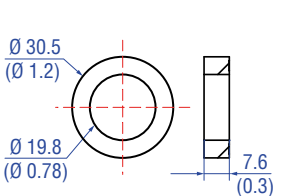
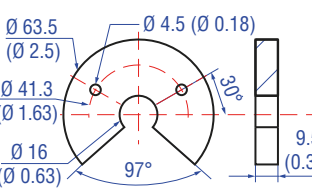
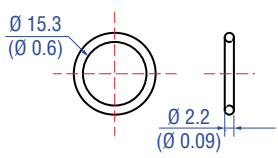
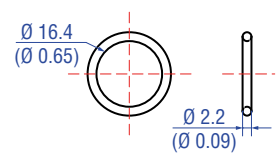
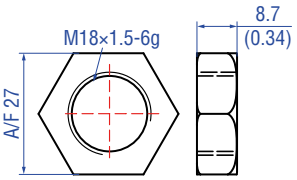
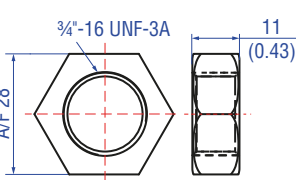
Material: Stainless steel 1.4305 (AISI 303)  
Order O-rings separately:  
O-ring 15x2: Part no. 560 853  
O-ring 16.4x2.2: Part no. 560 315

4.16 Frequently ordered accessories for Temposonics® RFV – Additional options see [Accessories Catalog](#)  551444

Position magnets			
			
<p><b>U-magnet OD33</b> Part no. 251 416-2</p>	<p><b>Ring magnet OD60</b> Part no. MT0162</p>	<p><b>Ring magnet</b> Part no. 402 316</p>	<p><b>U-magnet OD63.5</b> Part no. 201 553</p>
<p>Material: PA ferrite GF20 Weight: Approx. 11 g Surface pressure: Max. 40 N/mm<sup>2</sup> Fastening torque for M4 screws: 1 Nm Operating temperature: -40...+120 °C (-40...+248 °F)</p>	<p>Material: AlCuMgPb, magnets compound-filled Weight: Approx. 90 g Surface pressure: Max. 20 N/mm<sup>2</sup> Fastening torque for M4 screws: 1 Nm Operating temperature: -40...+75 °C (-40...+167 °F)</p>	<p>Material: PA ferrite coated Weight: Approx. 13 g Surface pressure: Max. 20 N/mm<sup>2</sup> Operating temperature: -40...+100 °C (-40...+212 °F)</p>	<p>Material: PA 66-GF30, magnets compound-filled Weight: Approx. 26 g Surface pressure: 20 N/mm<sup>2</sup> Fastening torque for M4 screws: 1 Nm Operating temperature: -40...+75 °C (-40...+167 °F)</p>
O-rings		Mounting accessories	
			
<p><b>O-ring for threaded flange</b> M18x1.5-6g Part no. 401 133</p>	<p><b>O-ring for threaded flange</b> ¾"-16 UNF-3A Part no. 560 315</p>	<p><b>Hex jam nut M18x1.5-6g</b> Part no. 500 018</p>	<p><b>Hex jam nut ¾"-16 UNF-3A</b> Part no. 500 015</p>
<p>Material: Fluoroelastomer Durometer: 75 ±5 Shore A Operating temperature: -40...+204 °C (-40...+400 °F)</p>	<p>Material: Fluoroelastomer Durometer: 75 ±5 Shore A Operating temperature: -40...+204 °C (-40...+400 °F)</p>	<p>Material: Steel, zinc plated</p>	<p>Material: Steel, zinc plated</p>
Mounting accessories			
			
<p><b>Threaded flange M18x1.5-6g</b> Part no. 404 874</p> <p>Material: Stainless steel 1.4305 (AISI 303) Order O-rings separately: O-ring 15x2: Part no. 560 853 O-ring 15.3x2.2: Part no. 401 133</p>	<p><b>Threaded flange ¾"-16 UNF-3A</b> Part no. 404 875</p> <p>Material: Stainless steel 1.4305 (AISI 303) Order O-rings separately: O-ring 15x2: Part no. 560 853 O-ring 16.4x2.2: Part no. 560 315</p>	<p><b>Adapter plate</b> Part no. 255 198</p> <p>Adapter plate for mounting an RFV-B as replacement for an RF-C. Order the RFV-B with the addition H003</p>	

Mounting accessories



**Sensor rod with threaded flange with flat-face (M18x1.5-6g) and O-ring**  
HD [length mm: XXXX] M  
HD [length in.: XXX.X] U

Pressure rod Ø: 12.7 mm (0.5 in.)  
Length: 100...7500 mm (4...295 in.)  
Operating pressure: 350 bar (5076 psi)  
Material flange:  
Stainless steel 1.4305 (AISI 303)  
Material rod:  
Stainless steel 1.4301 (AISI 304)



**Sensor rod with threaded flange with flat-face (3/4"-16 UNF-3A) and O-ring**  
HL [length mm: XXXX] M  
HL [length in.: XXX.X] U

Pressure rod Ø: 12.7 mm (0.5 in.)  
Length: 100...7500 mm (4...295 in.)  
Operating pressure: 350 bar (5076 psi)  
Material flange:  
Stainless steel 1.4305 (AISI 303)  
Material rod:  
Stainless steel 1.4301 (AISI 304)



**Sensor rod with threaded flange with raised-face (3/4"-16 UNF-3A) and O-ring**  
HP [length mm: XXXX] M  
HP [length in.: XXX.X] U

Pressure rod Ø: 12.7 mm (0.5 in.)  
Length: 100...7500 mm (4...295 in.)  
Operating pressure: 350 bar (5076 psi)  
Material flange:  
Stainless steel 1.4305 (AISI 303)  
Material rod:  
Stainless steel 1.4301 (AISI 304)



**Profile with flange**  
HFP [length mm: XXXXX] M  
HFP [length in.: XXXX.X] U

Length: Max. 20,000 mm (max. 787 in.)  
Ingress protection: IP30  
Material: Aluminum

4.17 Frequently ordered accessories for Temposonics® RDV – Additional options see [Accessories Catalog](#) 551444

Position magnets

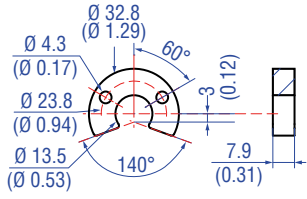
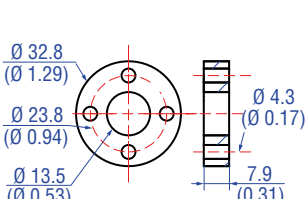
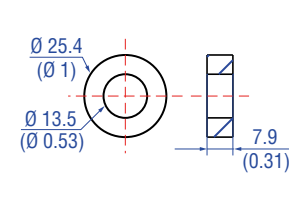
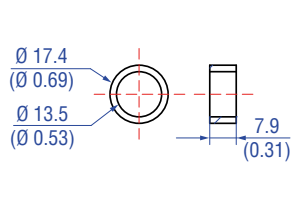
			
<p><b>U-magnet OD33</b> Part no. 251 416-2</p>	<p><b>Ring magnet OD33</b> Part no. 201 542-2</p>	<p><b>Ring magnet OD25.4</b> Part no. 400 533</p>	<p><b>Ring magnet OD17.4</b> Part no. 401 032</p>
<p>Material: PA ferrite GF20 Weight: Approx. 11 g Surface pressure: Max. 40 N/mm<sup>2</sup> Fastening torque for M4 screws: 1 Nm Operating temperature: -40...+120 °C (-40...+248 °F)</p> <p>Marked version for sensors with internal linearization: Part no. 254 226</p>	<p>Material: PA ferrite GF20 Weight: Approx. 14 g Surface pressure: Max. 40 N/mm<sup>2</sup> Fastening torque for M4 screws: 1 Nm Operating temperature: -40...+120 °C (-40...+248 °F)</p> <p>Marked version for sensors with internal linearization: Part no. 253 620</p>	<p>Material: PA ferrite Weight: Approx. 10 g Surface pressure: Max. 40 N/mm<sup>2</sup> Operating temperature: -40...+120 °C (-40...+248 °F)</p> <p>Marked version for sensors with internal linearization: Part no. 253 621</p>	<p>Material: PA neobond Weight: Approx. 5 g Surface pressure: Max. 20 N/mm<sup>2</sup> Operating temperature: -40...+105 °C (-40...+221 °F)</p>

Magnet spacer

O-rings

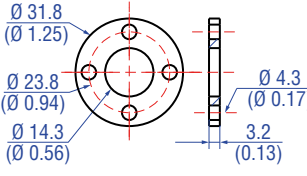
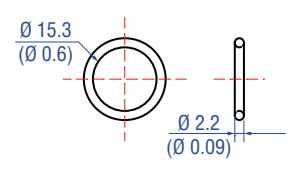
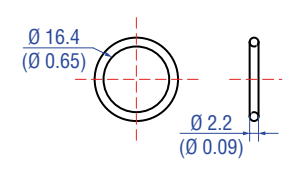
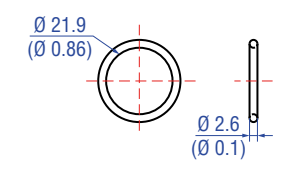
			
<p><b>Magnet spacer</b> Part no. 400 633</p>	<p><b>O-ring for threaded flange M18x1.5-6g</b> Part no. 401 133</p>	<p><b>O-ring for threaded flange 3/4"-16 UNF-3A</b> Part no. 560 315</p>	<p><b>O-ring for pressure fit flange Ø 26.9 mm</b> Part no. 560 705</p>
<p>Material: Aluminum Weight: Approx. 5 g Surface pressure: Max. 20 N/mm<sup>2</sup> Fastening torque for M4 screws: 1 Nm</p>	<p>Material: Fluoroelastomer Durometer: 75 ±5 Shore A Operating temperature: -40...+204 °C (-40...+400 °F)</p>	<p>Material: Fluoroelastomer Durometer: 75 ±5 Shore A Operating temperature: -40...+204 °C (-40...+400 °F)</p>	<p>Material: Nitrile rubber Operating temperature: -53...+107 °C (-65...+225 °F)</p>

O-rings

Mounting accessories

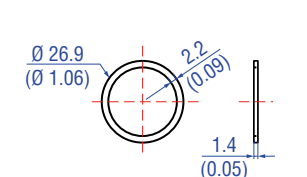
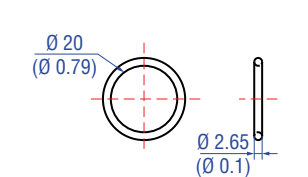
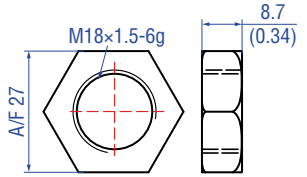
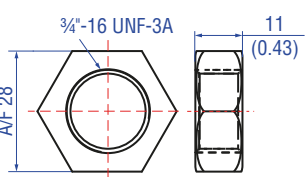
			
<p><b>Back-up ring for pressure fit flange Ø 26.9 mm</b> Part no. 560 629</p>	<p><b>O-ring for mounting block with bottom entry</b> Part no. 561 435</p>	<p><b>Hex jam nut M18x1.5-6g</b> Part no. 500 018</p>	<p><b>Hex jam nut 3/4"-16 UNF-3A</b> Part no. 500 015</p>
<p>Material: Polymyte Durometer: 90 Shore A</p>	<p>Material: FKM Durometer: 80 ± 5 Shore A Operating temperature: -15...+200 °C (5...+392 °F)</p>	<p>Material: Steel, zinc plated</p>	<p>Material: Steel, zinc plated</p>



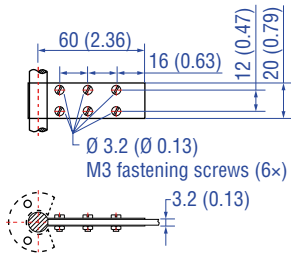

## Mounting accessories

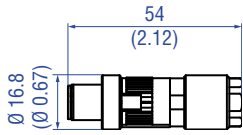
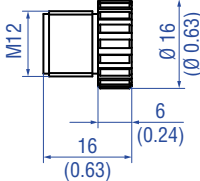
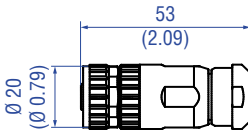
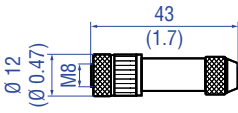
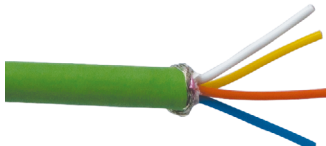

### Fixing clip Part no. 561 481

Application: Used to secure sensor rods ( $\varnothing 10$  mm ( $\varnothing 0.39$  in.)) when using an U-magnet or block magnet  
Material: Brass, non-magnetic





4.18 Frequently ordered accessories for POWERLINK output – Additional options see [Accessories Catalog](#) 551444

Cable connectors* – Signal		Cable connectors* – Power	
			
<p><b>M12 D-coded male connector (4 pin), straight</b> Part no. 370 523</p> <p>Material: Zinc nickel-plated Termination: Insulation-displacement Cable Ø: 6...7.2 mm (0.2...0.28 in.) Wire: 24 AWG – 22 AWG Operating temperature: –25...+85 °C (–13...+185 °F) Ingress protection: IP65 / IP67 (correctly fitted) Fastening torque: 0.6 Nm</p>	<p><b>M12 connector end cap</b> Part no. 370 537</p> <p>Female connectors M12 should be covered by this protective cap Material: Brass nickel-plated Ingress protection: IP67 (correctly fitted) Fastening torque: 0.39...0.49 Nm</p>	<p><b>M12 A-coded female connector (4 pin/5 pin), straight</b> Part no. 370 677</p> <p>Material: GD-Zn, Ni Termination: Screw Contact insert: CuZn Cable Ø: 4...8 mm (0.16...0.31 in.) Wire: max. 1.5 mm<sup>2</sup> (16 AWG) Operating temperature: –30...+85 °C (–22...+185 °F) Ingress protection: IP67 (correctly fitted) Fastening torque: 0.6 Nm</p>	<p><b>M8 female connector (4 pin), straight</b> Part no. 370 504</p> <p>Material: CuZn nickel plated Termination: Solder Cable Ø: 3.5...5 mm (0.14...0.28 in.) Wire: 0.25 mm<sup>2</sup> Operating temperature: –40...+85 °C (–40...+185 °F) Ingress protection: IP67 (correctly fitted) Fastening torque: 0.5 Nm</p>
Cables		Cable sets	
			
<p><b>PUR signal cable</b> Part no. 530 125</p> <p>Material: PUR jacket; green Features: Cat 5, highly flexible, halogen free, suitable for drag chains, mostly oil &amp; flame resistant Cable Ø: 6.5 mm (0.26 in.) Cross section: 2 × 2 × 0.35 mm<sup>2</sup> (22 AWG) Bending radius: 6 × D (fixed installation) Operating temperature: –20...+60 °C (–4...+140 °F)</p>	<p><b>PVC power cable</b> Part no. 530 108</p> <p>Material: PVC jacket; gray Features: Shielded, flexible, mostly flame resistant Cable Ø: 4.9 mm (0.19 in.) Cross section: 3 × 0.34 mm<sup>2</sup> Bending radius: 5 × D (fixed installation) Operating temperature: –30...+80 °C (–22...+176 °F)</p>	<p><b>Signal cable with M12 D-coded male connector (4 pin), straight – M12 D-coded, male connector (4 pin), straight</b> Part no. 530 064</p> <p>Material: PUR jacket; green Feature: Cat 5e Cable length: 5 m (16.4 ft) Cable Ø: 6.5 mm (0.26 in.) Ingress protection: IP65, IP67, IP68 (correctly fitted) Operating temperature: –30...+70 °C (–22...+158 °F)</p>	<p><b>Signal cable with M12 D-coded male connector (4 pin), straight – RJ45 male connector, straight</b> Part no. 530 065</p> <p>Material: PUR jacket; green Feature: Cat 5e Cable length: 5 m (16.4 ft) Cable Ø: 6.5 mm (0.26 in.) Ingress protection M12 connector: IP67 (correctly fitted) Ingress protection RJ45 connector: IP20 (correctly fitted) Operating temperature: –30...+70 °C (–22...+158 °F)</p>

\*/ Follow the manufacturer's mounting instructions

Controlling design dimensions are in millimeters and measurements in ( ) are in inches

Color of connectors and cable jacket may change. Color codes for the individual wires and technical properties remain unchanged.

Cable sets	Programming tools		
			
<p><b>Power cable with M8 female connector (4 pin), straight – pigtail</b>  <b>Part no. 530 066 (5 m (16.4 ft.))</b>  <b>Part no. 530 096 (10 m (32.8 ft.))</b>  <b>Part no. 530 093 (15 m (49.2 ft.))</b></p>	<p><b>Power cable with M12 A-coded female connector (5 pin), straight – pigtail</b>  <b>Part no. 370 673</b></p>	<p><b>TempoLink® kit for Tempsonics® R-Series V</b>  <b>Part no. TL-1-0-EM08 (D56)</b>  <b>Part no. TL-1-0-EM12 (D58)</b></p>	<p><b>TempoGate® smart assistant for Tempsonics® R-Series V</b>  <b>Part no. TG-C-0-Dxx</b>                      (xx indicates the number of R-Series V sensors that can be connected (even numbers only))</p>
<p>Material: PUR jacket; gray                      Feature: Shielded                      Cable Ø: 5 mm (0.2 in.)                      Operating temperature:                      –40...+90 °C (–40...+194 °F)</p>	<p>Material: PUR jacket; black                      Feature: Shielded                      Cable length: 5 m (16.4 ft)                      Ingress protection: IP67 (correctly fitted)                      Operating temperature:                      –25...+80 °C (–13...+176 °F)</p>	<ul style="list-style-type: none"> <li>• Connect wirelessly via Wi-Fi enabled device or via USB with the diagnostic tool</li> <li>• Simple connectivity to the sensor via 24 VDC power line (permissible cable length: 30 m)</li> <li>• User friendly interface for mobile devices and desktop computers</li> <li>• See data sheet “TempoLink® smart assistant” (document part no.: <a href="#">552070</a>) for further information</li> </ul>	<ul style="list-style-type: none"> <li>• OPC UA server for diagnostics of the R-Series V</li> <li>• For installation in the control cabinet</li> <li>• Connection via LAN and Wi-Fi</li> <li>• See data sheet “TempoGate® smart assistant” document part no.: <a href="#">552110</a> for further information</li> </ul>

Color of connectors and cable jacket may change. Color codes for the individual wires and technical properties remain unchanged.

## 5. Commissioning

### 5.1 Initial start-up

The position sensor R-Series V POWERLINK transfers position and velocity values via the POWERLINK output. POWERLINK is an Industrial Ethernet interface and is managed by the Ethernet POWERLINK Standardization Group (EPSG). The sensor and the corresponding XDD file (XML Device Description) are certified by EPSG.

#### NOTICE

##### Observe during commissioning

1. Before initial switch-on, check carefully if the sensor has been connected correctly.
2. Position the magnet in the measuring range of the sensor during first commissioning and after replacement of the magnet.
3. Ensure that the controller, to which the sensor is connected, does not react in an uncontrolled way.
4. Ensure that the sensor is ready and in operation mode after switching on. The bus status LED is green.
5. Check the preset span start and end values of the measuring range (see chapter 4.8) and correct them via the customer's control system, if necessary.

### 5.2 LED status

A diagnostic display on the lid of the sensor informs about the current status of the sensor. The R-Series V POWERLINK is equipped with three LEDs:

- LED for status indication (condition indicator)
- LED for activity of the Ethernet connection at port 1 (link activity)
- LED for activity of the Ethernet connection at port 2 (link activity)

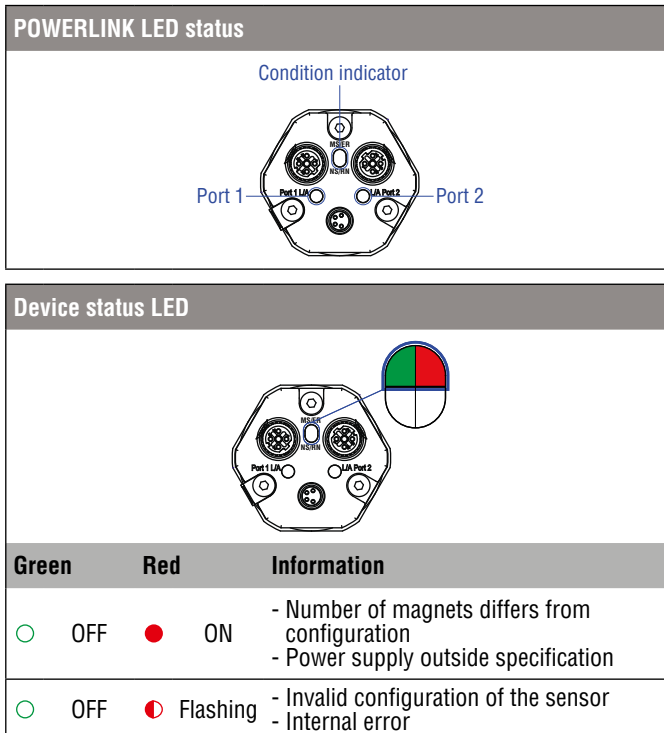

Fig. 80: LED status display, part 1

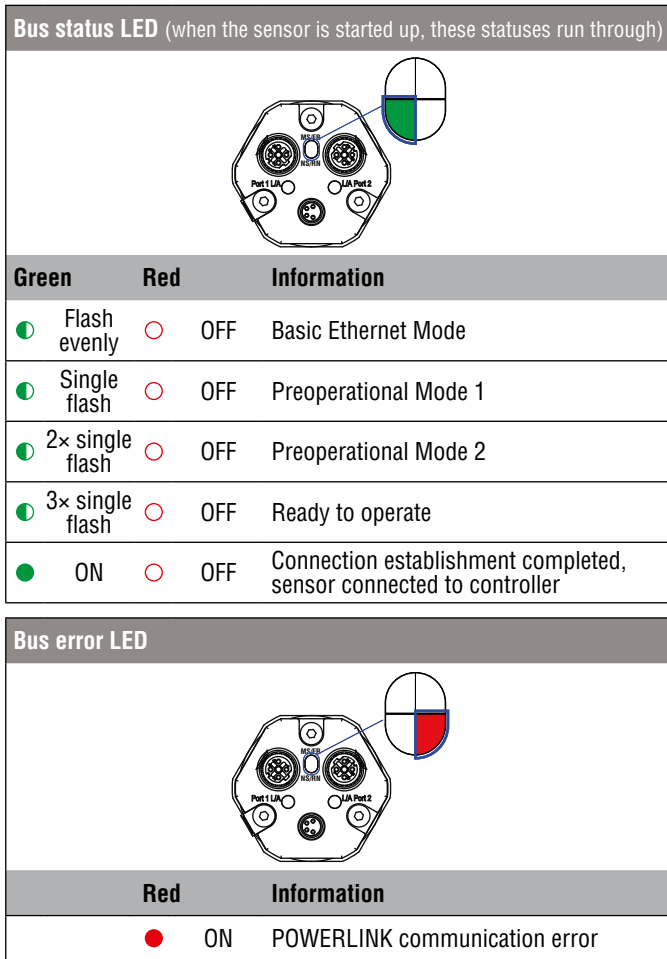

Fig. 81: LED status display, part 2

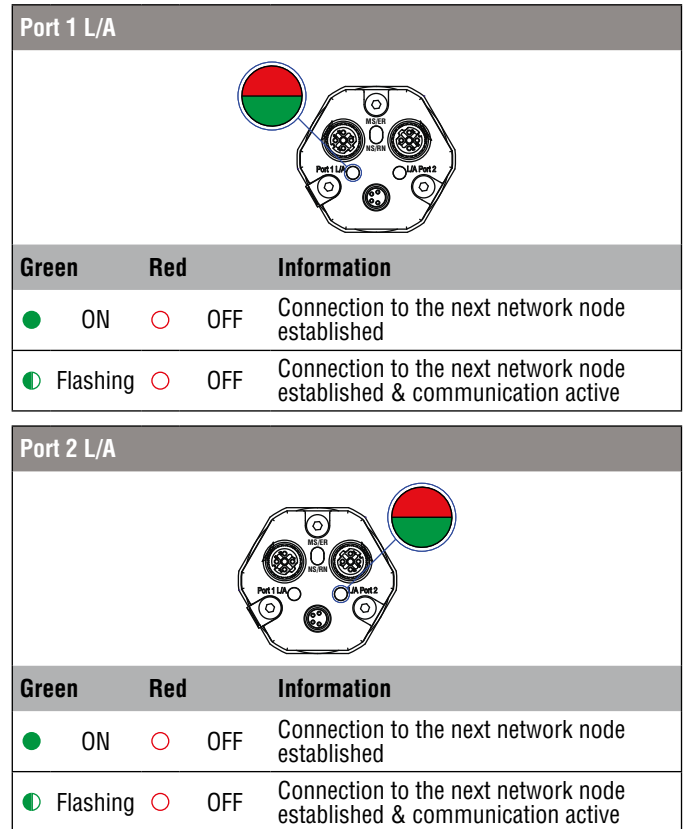

Fig. 82: LED status display, part 3

### 5.3 Topologies and hubs

POWERLINK supports various topologies when building up a network. Thus, the usage of linear, star, ring and tree topologies are supported. A hub is integrated in devices like the R-Series V POWERLINK sensors. With integrated hubs, a power failure will cause a communication interruption to the subsequent devices. This can be avoided for example by extending a line structure to a ring structure.

## 6. Node ID configuration of R-Series V POWERLINK

This chapter describes how to adjust the node ID of the R-Series V POWERLINK. The node ID is used to identify a device in a POWERLINK network. Each node ID only exists once in the network. The node ID can have a value between 1 and 240, where 240 is reserved for the Managing Node. The node ID set on the POWERLINK device must match the node ID assigned in the project. There are two ways to set the node ID on the R-Series V POWERLINK.

**Section 6.1** describes the setting of the node ID via the TempoLink® smart assistant.

**Section 6.2** explains the setting of the node ID via Automation Studio by B&R (Bernecker + Rainer Industrie-Elektronik Ges.m.b.H.).

### 6.1 Setting the node ID via TempoLink® smart assistant

TempoLink® smart assistant is an accessory of the R-Series V family of sensors. On the R-Series V POWERLINK, it is used to set the node ID and provide additional status information for diagnostics of the sensor.

#### 6.1.1. Connection of TempoLink® smart assistant to sensor and power supply

Before changing the node ID at the sensor and connecting TempoLink® smart assistant to the sensor, disconnect the sensor from the power supply and if the sensor is connected to a control disconnect it, too. Use the adapter cable for connection of the TempoLink® smart assistant to the R-Series V sensor. Connect the barrel connector of the adapter cable to the connection point labeled “OUTPUT SENSOR” on the TempoLink® smart assistant. Next, connect the female connector of the adapter cable to the power supply at the R-Series V POWERLINK sensor.

#### NOTICE

- When disconnecting the power supply of the sensor possibly error messages occur at the connected controller.
- Do not exceed the maximum cable length between TempoLink® smart assistant and R-Series V sensor of 30 m (98.4 ft.)

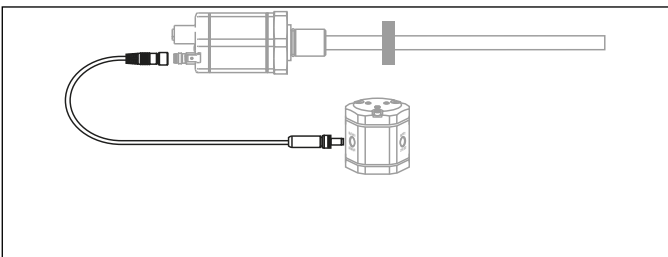

Fig. 83: Connection of TempoLink® smart assistant to R-Series V sensor

Connect the TempoLink® smart assistant to the power supply using the plug-in power supply with plug adapters. Connect the barrel connector to the “INPUT 24 VDC” port on the TempoLink® smart assistant. Next, insert the plug into the outlet. Additional outlet adapters are supplied to support regional requirements.

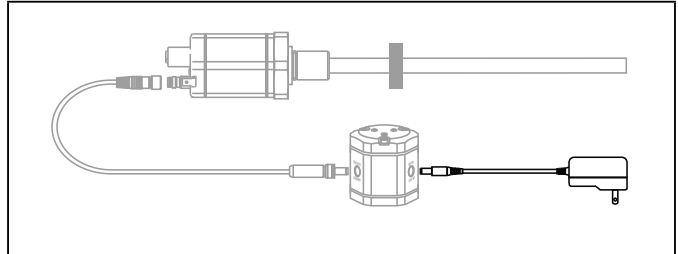

Fig. 84: Connection of TempoLink® smart assistant with the plug-in power supply

#### 6.1.2. Connection of TempoLink® smart assistant to smartphone, tablet or computer

Connect to a smartphone, tablet or computer to display the graphical user interface of the TempoLink® smart assistant.

#### Connecting a Wi-Fi enabled device to the integrated Wi-Fi access point<sup>3</sup>

Activate Wi-Fi on the device and choose the network “TempoLink®\_xxxx” (xxxx indicates the last four digits of the serial number). The default password is the serial number printed on the label on the bottom of the TempoLink® smart assistant.

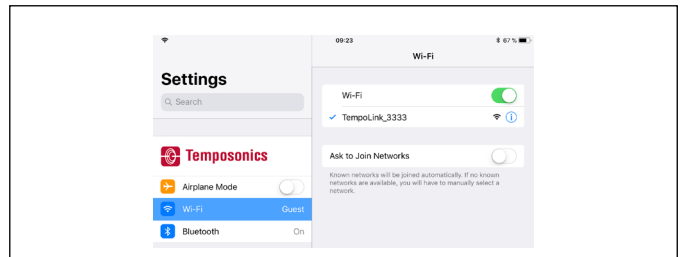

Fig. 85: Choose the network “TempoLink®\_xxxx” in the Wi-Fi settings of the Wi-Fi-enabled device

#### NOTICE

If you are using a mobile device, ensure cellular data is off. Depending on your operation system, message can appear, that there is no internet access. TempoLink® smart assistant does not need internet access. Connecting to the user interface may take longer if other Wi-Fi and mobile data connections are active within range.

3/ The integrated Wi-Fi access point does not provide internet access

### Connecting a computer via USB connection

The TempoLink smart assistant can also be connected via USB. If the computer is Wi-Fi enabled deactivate Wi-Fi on the computer before setting up the USB connection.

Connect the USB cable with the micro USB connector to the port labeled “USB” on the TempoLink® smart assistant. Next, connect the USB type-A connector to a free USB port of the computer. The USB connection simulates a network card. In the folder “network connections” on the computer the connection is shown as “IP-over-USB” or “Remote NDIS”.

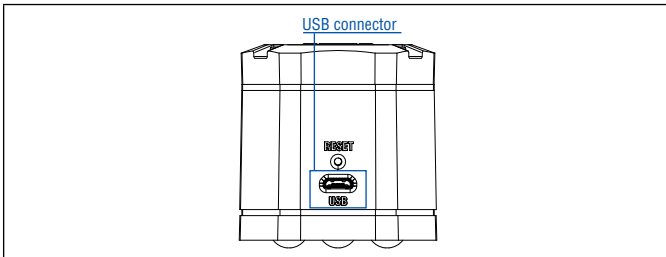

Fig. 86: USB port on the TempoLink® smart assistant

**NOTICE**

- Only one device can be connected to the TempoLink® smart assistant at a time in order to display the graphical user interface.
- Disable all Wi-Fi and LAN connections before connecting TempoLink® smart assistant via USB. Connecting to the user interface may take longer if Wi-Fi and LAN connections are active.
- It may be useful to press CTRL + F5 to delete cached text and images from prior to launching the <http://tempolink.local> website.

### 6.1.3. Establishing a connection via browser

After the connection via Wi-Fi or USB is established, open the browser and go to the website-URL: **http://tempolink.local**  
It is recommended to use the browser Mozilla Firefox, Google Chrome, Microsoft Edge or Apple Safari.

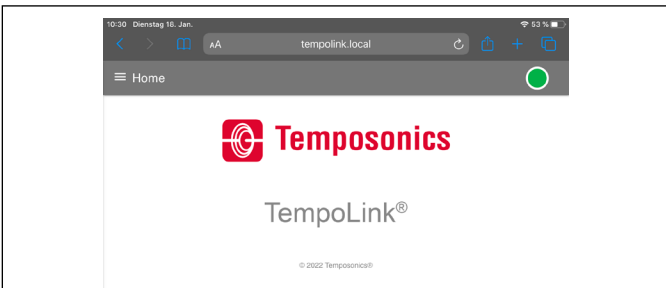

Fig. 87: Start page of the graphical user interface

The connection icon in the top right shows the status of the connection between the TempoLink® smart assistant and the sensor.

Connection status	
<b>Green</b>	<b>Information</b>
● ON	Connection to sensor is established
<b>Red</b>	<b>Information</b>
● ON	Connection to sensor is not established
<b>Blue</b>	<b>Information</b>
● ON	Sensor in command mode

Fig. 88: Connection status

### 6.1.4. Graphical User Interface (GUI)

Click the menu symbol ≡ in the top left to get to the main menu:

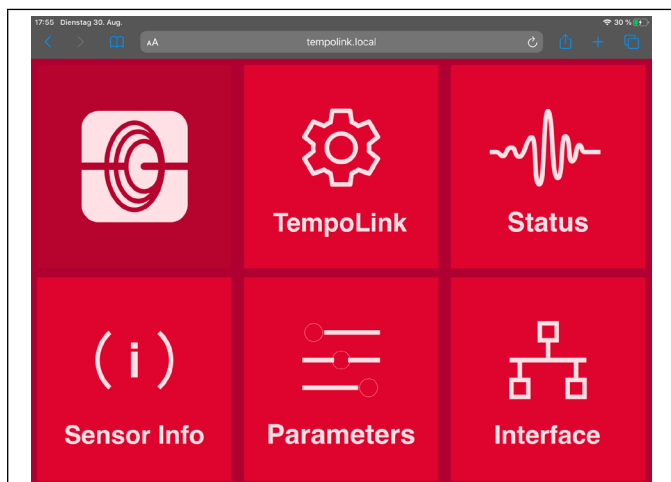

Fig. 89: Main menu of the graphical user interface (GUI)

To change the node ID of the connected sensor, select the menu item Interface (Fig. 89). Interface includes information about the network settings of the sensor. To change the settings you must start the command mode. In the command mode, the sensor does not output a position value. By clicking the ENTER COMMAND MODE button a new menu will open. After reading the information, enter the word COMMAND and confirm by clicking OK (Fig. 90).

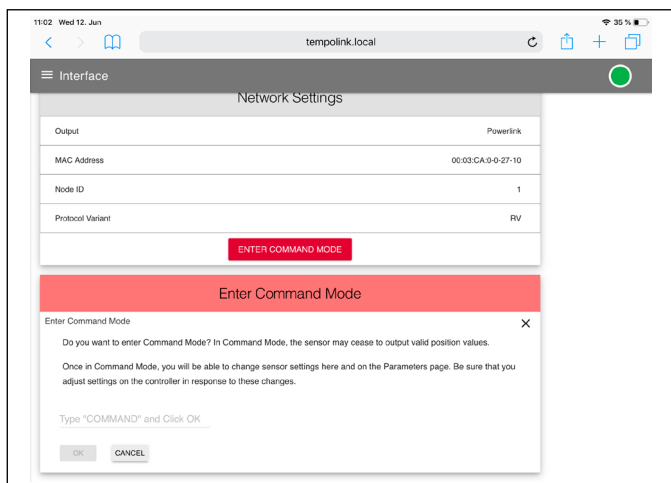



Fig. 90: Starting the command mode to change settings of the connected sensor

After entering the command mode the connection icon on the top right will turn from green to blue. A pencil icon  will appear to the right of the node ID. By clicking the pencil icon a new window for configuring the node ID will open. Enter the new node ID of the sensor and confirm the change by clicking the SUBMIT button (Fig. 91). Only values between 1 and 239 are permitted. The value 240 is reserved for the Managing Node.

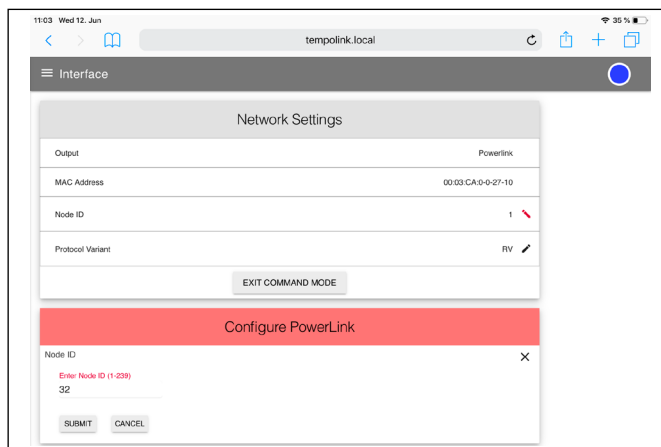

Fig. 91: Changing the node ID of the connected sensor

After the node ID has been configured, click the EXIT COMMAND MODE button. A new window for exiting the command mode will open (Fig. 92). Click the SAVE AND EXIT button to exit the command mode and to transfer the changed node ID to the sensor. The sensor returns to the normal function and outputs the current position value. When you exit the command mode the connection icon changes to green.

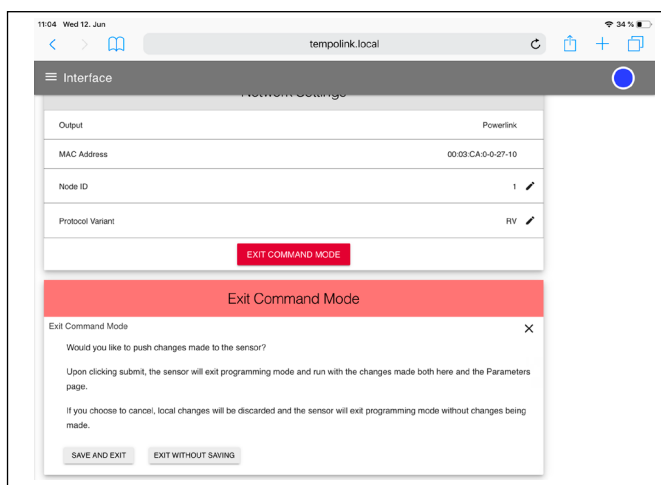

Fig. 92: Exiting the command mode

The other menu items contain the following information:

**TempoLink:** Includes information about the TempoLink® smart assistant

**Status:** Includes current information about the sensor status

**Sensor Info:** Includes information about the connected sensor

**Parameters:** Includes information about the operational settings of the connected sensor

#### NOTICE

- To enable the controller to communicate with the sensor, the node ID set on the sensor must also be set on the controller.
- For detailed information about the TempoLink® smart assistant see its operation manual (document no. [551986](#)).

## 6.2 Setting the node ID via “Automation Studio”

The following is a description how to set the node ID of the R-Series POWERLINK as well as the R-Series V POWERLINK using “Automation Studio” by B&R (Bernecker + Rainer Industrie-Elektronik Ges.m.b.H.).

### 6.2.1. Hardware setup

In this example R-Series POWERLINK is used with node ID 32 (default value). It also applies to R-Series V POWERLINK with default node ID 1. In this example the sensor is connected to an interface module X20IF1082-2 which is mounted to a control system X20CP3485-1. The screenshot of the hardware setup in “Automation Studio” is shown in Fig. 93.

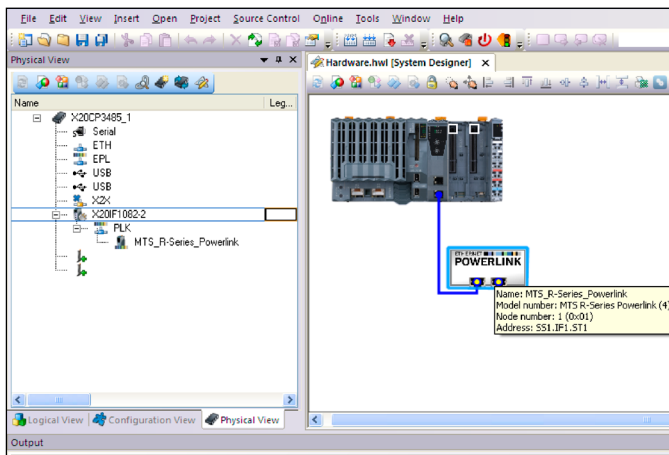

Fig. 93: Hardware setup in “Automation Studio”

### 6.2.2. Defined data types

To implement a state machine an enumeration type has to be defined that contains all used states (Fig. 94 and Fig. 95).

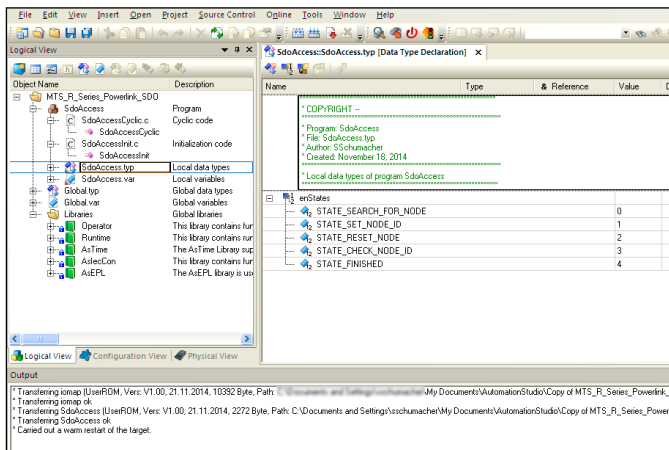

Fig. 94: Defining an enumeration type

Name	Description
STATE_SEARCH_FOR_NODE	This is the initial state in this project. In this state, PLC tries to read the vendor ID of controlled nodes starting from node ID 1 up to node ID 239 (all node IDs which are supposed to be controlled nodes. The node ID 240 is reserved for the managing node) until it detects a controlled node with vendor ID 0x40 (MTS vendor ID).
STATE_SET_NODE_ID	PLC enters into this state when the operations of STATE_SEARCH_FOR_NODE have been finished. In this example the node ID of the first controlled node found with vendor ID 0x40 is set to 1.
STATE_RESET_NODE	PLC enters into this state when the operations of STATE_SET_NODE_ID have been finished. The sensor has to be reset in order to communicate using the new node ID. In this state a reset of the sensor is done.
STATE_CHECK_NODE_ID	PLC enters into this state when the operations of STATE_RESET_NODE have been finished. The node ID of the sensor is read and stored to a local variable.
STATE_FINISHED	PLC enters into this state when the operations of STATE_CHECK_NODE_ID have been finished.

Fig. 95: Defined data types

### 6.2.3. Used variables

The following local variables are used to change the node ID (Fig. 96).

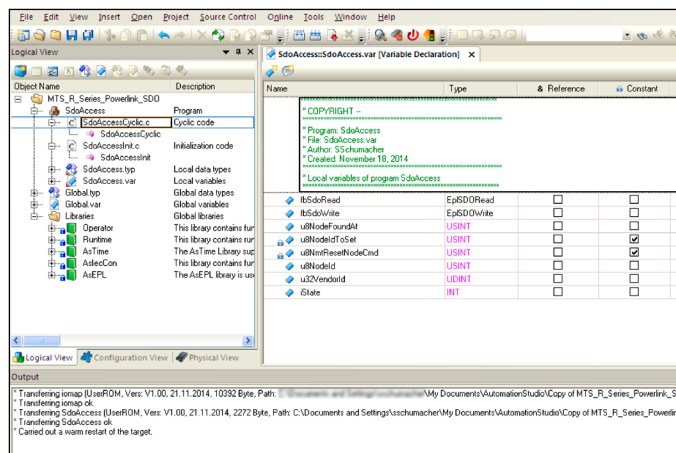

Fig. 96: Screenshot of used variables

Name	Description
<b>fbSdoRead</b>	Predefined function block (AsEPL library) to execute read operations on POWERLINK nodes.
<b>fbSdoWrite</b>	Predefined function block (AsEPL library) to execute write operations on POWERLINK nodes.
<b>u8NodeFoundAt</b>	Unsigned 8 bit integer to store the node ID of the first controlled node with MTS vendor ID which has been found.
<b>u8NodeidToSet</b>	Constant unsigned 8 bit integer which contains the node ID that shall be set.
<b>u8NmtResetNodeCmd</b>	Constant unsigned 8 bit integer for the command which has to be sent to the reset SDO in order to reset the sensor.
<b>u32VendorId</b>	Unsigned 32 bit integer to store the vendor ID of the node which is currently checked in state STATE_SEARCH_FOR_NODE.
<b>iState</b>	Integer variable which represents the current state of the implemented state machine.

Fig. 97: Variables used

### 6.2.4. Program executed by PLC once after start-up (SdoAccessInit.c)

This program initializes the state of the implemented state machine as well as the node ID variable. It also sets the variable which is used to store the node ID of the first found controlled node with vendor ID from Temposonics to a value which is invalid for a controlled node (source code below).

#### Source Code "SdoAccessInit.c"

```

/*****
 * COPYRIGHT --
 *****/
 * Program: SdoAccess
 * File: SdoAccessInit.c
 * Author: S.Schumacher
 * Created: November 18, 2014
 *****/
 * Implementation of program SdoAccess
 *****/

#include <bur/plctypes.h>
#ifdef _DEFAULT_INCLUDES
#include <AsDefault.h>
#endif

void _INIT SdoAccessInit(void)
{
    iState = STATE_SEARCH_FOR_NODE; //initialize current state
    u8Nodeid = 0; //initialize node id currently using for search
    u8NodeFoundAt = 255; //set node id found to invalid node id
}

```

### 6.2.5. Program executed by PLC cyclically (SdoAccessCyclic.c)

This program implements the state machine and changes the node ID of R-Series POWERLINK as well as R-Series V POWERLINK (source code on page 63).

## Source Code “SdoAccessCyclic.c”

```

/*****
* COPYRIGHT --
*****
* Program: SdoAccess
* File: SdoAccessCyclic.c
* Author: S.Schumacher
* Created: November 18, 2014
*****
* Implementation of program SdoAccess
*****/

#include <bur/plctypes.h>
#ifdef _DEFAULT_INCLUDES
#include <AsDefault.h>
#endif
void _CYCLIC SdoAccessCyclic(void)
{
    if (fbSdoRead.status != ERR_FUB_BUSY && fbSdoWrite.status != ERR_FUB_BUSY)
    {
        //currently there is no SDO operation in progress
        //initiate SDO operation
        switch (iState)
        {
            case STATE_SEARCH_FOR_NODE:
                if (u32VendorId == 0x40)
                {
                    //go to next step
                    u8NodeFoundAt = u8NodeId;
                    iState++;
                    break;
                }
                else
                {
                    //search at next ID
                    u8NodeId++;
                    if (u8NodeId > 239)
                        u8NodeId = 1;
                }
                fbSdoRead.pDevice = "SS1.IF1"; //interface sensor is connected to
                fbSdoRead.node = u8NodeId; //node id of sensor
                fbSdoRead.index = 0x1018; //index of vendor ID
                fbSdoRead.subindex = 1; //subindex of vendor ID
                fbSdoRead.pData = &u32VendorId; //variable to store value to
                fbSdoRead.dataLen = sizeof(u32VendorId); //size of the variable to store value to
                fbSdoRead.enable = 1; //enable the read operation
                fbSdoWrite.enable = 0; //disable write operation
                break;
            case STATE_SET_NODE_ID:
                fbSdoWrite.pDevice = "SS1.IF1"; //interface sensor is connected to
                fbSdoWrite.node = u8NodeFoundAt; //node id of sensor
                fbSdoWrite.index = 0x1f93; //index of node ID
                fbSdoWrite.subindex = 3; //subindex of node ID
                fbSdoWrite.pData = &u8NodeIdToSet; //variable containing value to set
                fbSdoWrite.dataLen = sizeof(u8NodeIdToSet); //size of the variable containing value to set
                fbSdoWrite.enable = 1; //enable write operation
                fbSdoRead.enable = 0; //disable read operation
                //go to next step
                iState++;
                break;
            case STATE_RESET_NODE:
                fbSdoWrite.pDevice = "SS1.IF1"; //interface sensor is connected to
                fbSdoWrite.node = u8NodeFoundAt; //node id of sensor
                fbSdoWrite.index = 0x1f9e; //index of nmt reset
                fbSdoWrite.subindex = 0; //subindex of nmt reset
                fbSdoWrite.pData = &u8NmtResetNodeCmd; //variable containing value to set
                fbSdoWrite.dataLen = sizeof(u8NmtResetNodeCmd); //size of the variable containing value to set
                fbSdoWrite.enable = 1; //enable write operation
                fbSdoRead.enable = 0; //disable read operation
                //go to next step
                iState++;
                break;
            case STATE_CHECK_NODE_ID:
                fbSdoRead.pDevice = "SS1.IF1"; //interface sensor is connected to
                fbSdoRead.node = u8NodeIdToSet; //node id of sensor
                fbSdoRead.index = 0x1f93; //index of node ID
                fbSdoRead.subindex = 3; //subindex of node ID
                fbSdoRead.pData = &u8NodeId; //variable to store value to
                fbSdoRead.dataLen = sizeof(u8NodeId); //size of the variable to store value to
                fbSdoRead.enable = 1; //enable the read operation
                fbSdoWrite.enable = 0; //disable write operation
                //go to next step
                iState++;
                break;
            default:
                fbSdoRead.enable = 0; //disable read operation
                fbSdoWrite.enable = 0; //disable write operation
                break;
        }
        //execute SDO read if enabled
        EplSDORead(&fbSdoRead);
        //execute SDO write if enabled
        EplSDOWrite(&fbSdoWrite);
    }
}

```

### 6.2.6. Variable watch after successful execution of the implemented state machine

As shown in the screenshot of the variable watch, a controlled node with vendor ID from Temposonics has been found at node ID 32. The node ID has been successfully set to 1.

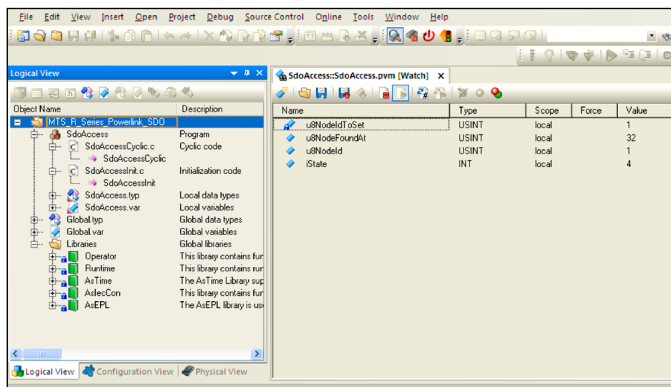

Fig. 98: Variable watch

As shown in the screenshot of the I/O mapping, the sensor is working well using its new node ID.

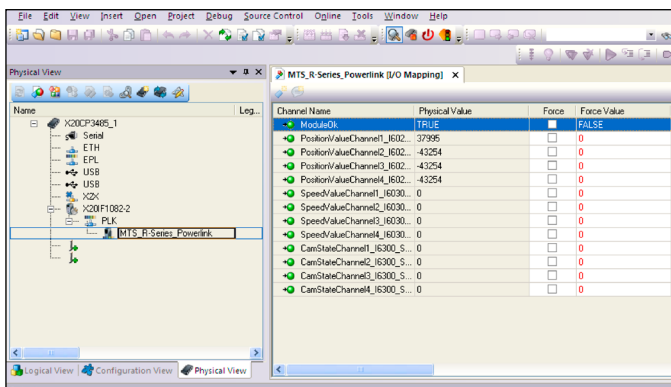

Fig. 99: I/O mapping of sensor with changed node ID

## 7. Integration of R-Series V POWERLINK in the control system

### Project integration

The project integration is described using an example with a B&R (Bernecker + Rainer Industrie-Elektronik Ges.m.b.H.) controller and the “Automation Studio” project engineering tool. In principle, you can integrate the device with any project planning tool and any hardware that uses a POWERLINK network.

### XDD file

A XDD file (XML Device Description) describes the properties and functions of the device, such as timing and configurable device parameters. The XDD file enables simple and easy integration of a POWERLINK device into a project engineering tool. The XDD file for R-Series V POWERLINK is packed in a zip file which is available for download on our homepage [www.temposonics.com](http://www.temposonics.com).

### NOTICE

Follow the information given in the controller operation manual.

### 7.1 Importing R-Series V POWERLINK sensor into the project tool

In the main menu "Tools", select the entry “Manage 3rd-Party Devices” (Fig. 100).

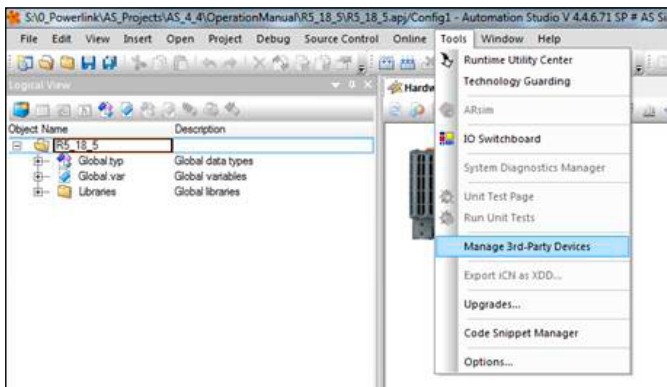

Fig. 100: Starting the 3rd-Party Device Manager

In the opening window the already imported 3rd-Party Devices are displayed. Click the button “Import Fieldbus Device(s)” (Fig. 101).

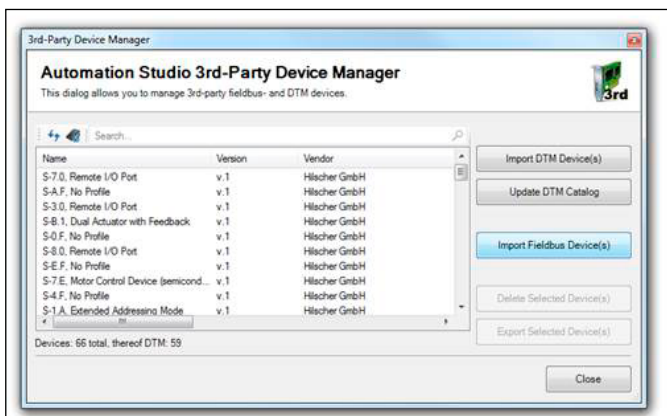

Fig. 101: Importing Fieldbus Devices with the 3rd-Party Device Manager

Navigate to the location where the XDD file for the R-Series V POWERLINK is stored. Select the XDD file and confirm by clicking the OK button. The import of the file begins (Fig. 102).

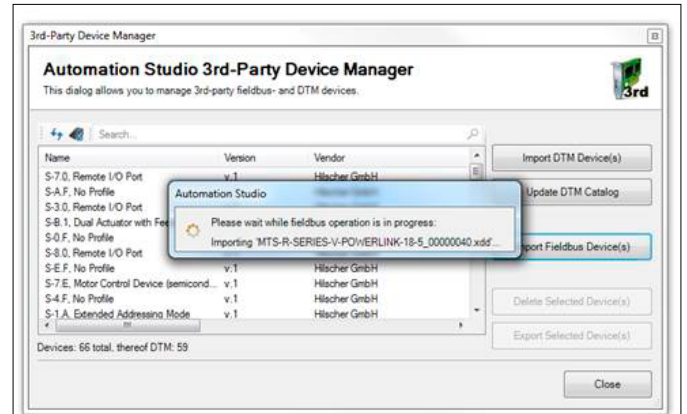

Fig. 102: Importing the XDD file for R-Series V POWERLINK

After the successful import, the XDD file can be displayed via the search in the manager (Fig. 103).

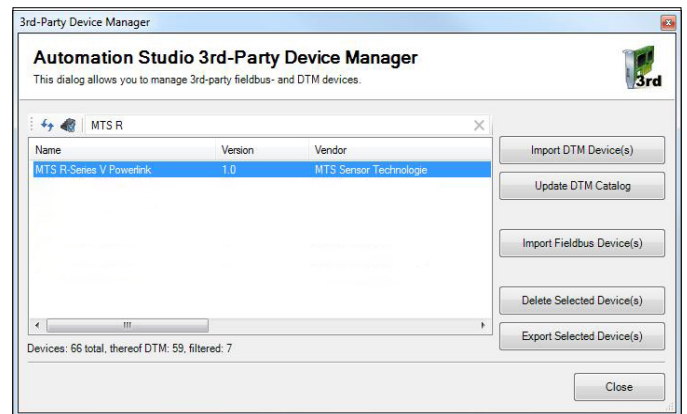

Fig. 103: Searching for R-Series V POWERLINK sensor via the 3rd-Party Device Manager

**Adding R-Series V POWERLINK to a network**

In the right of the main view is the “Toolbox - Hardware Catalog”. Choose the R-Series V POWERLINK in the “Toolbox - Hardware Catalog” and move it via drag and drop in the system designer where the sensor should be integrated in the network (Fig. 104).

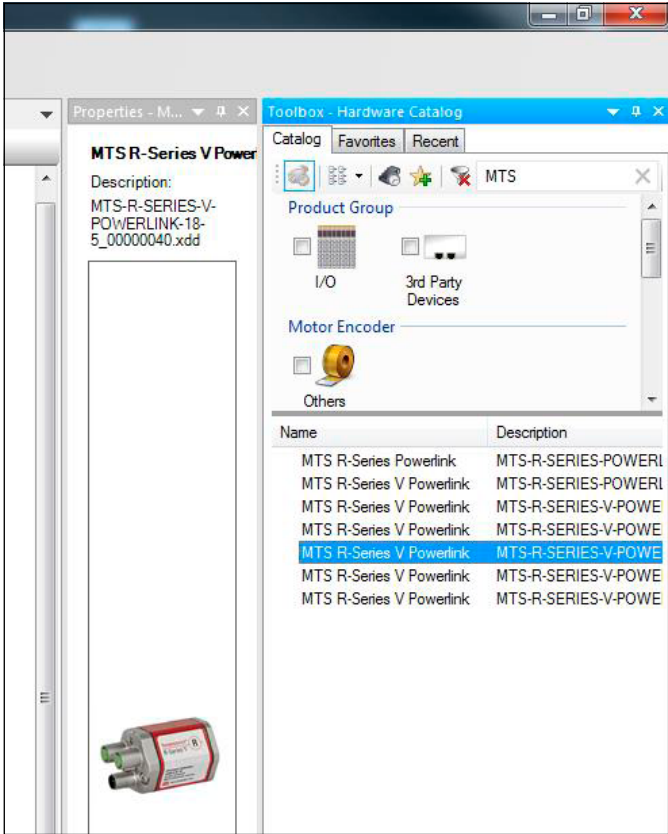

Fig. 104: Selecting R-Series V POWERLINK in the “Toolbox - Hardware Catalog”

Connect the sensor with the control (Fig. 105).

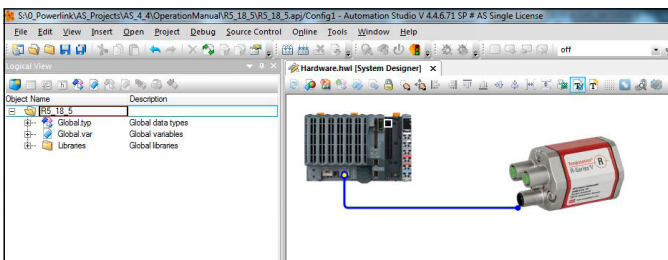

Fig. 105: Connect R-Series V POWERLINK sensor with control

As in the system designer also in the physical view on the left the sensor is connected to the control. To enable the control to communicate with the sensor, the node ID previously set on the sensor must be set on the control. Click on the sensor in the physical view with the right mouse button and select the entry “Node Number → Change Node Number” (Fig. 106). The node number on the control must be identical to the node ID of the device. The default node ID of R-Series V POWERLINK is 1. See the sections 6.1 and 6.2 to change the node ID of R-Series V POWERLINK.

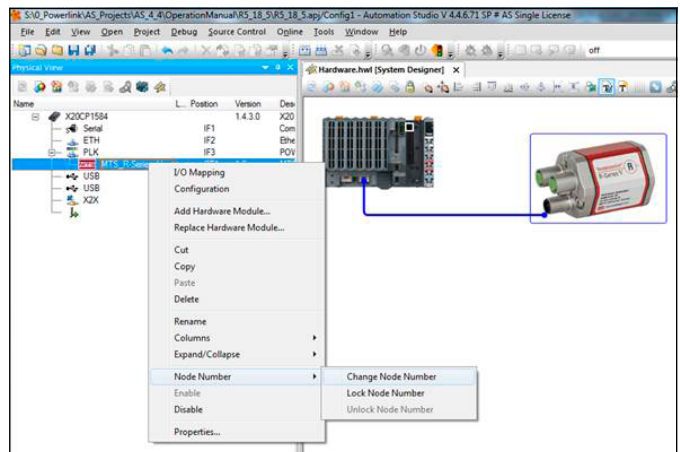

Fig. 106: Setting the node number of the connected device on the control

To configure the sensor, select the R-Series V POWERLINK sensor on the left side (physical view) again. The right mouse button takes you to the menu entry “Configuration” (Fig. 107.) The configuration tab in the main window will open.

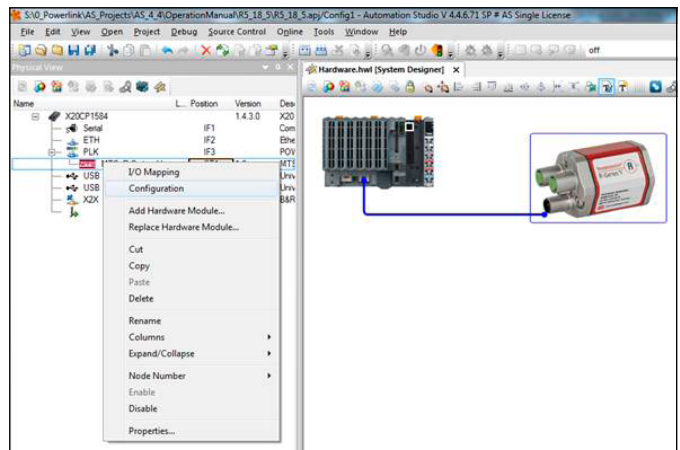

Fig. 107: Setting the node number of the connected device on the controller

The available configuration data of the sensor is divided into two groups:

- Channels: Measurement data of the sensor, that can be transferred cyclically. To activate cyclic transmission of a specific data item, click on the data item column called "Value" and change the entry from "None" to "Read" (Fig. 108).
- Device specific parameters: Configuration parameters of the sensor, which are transferred in the startup phase.

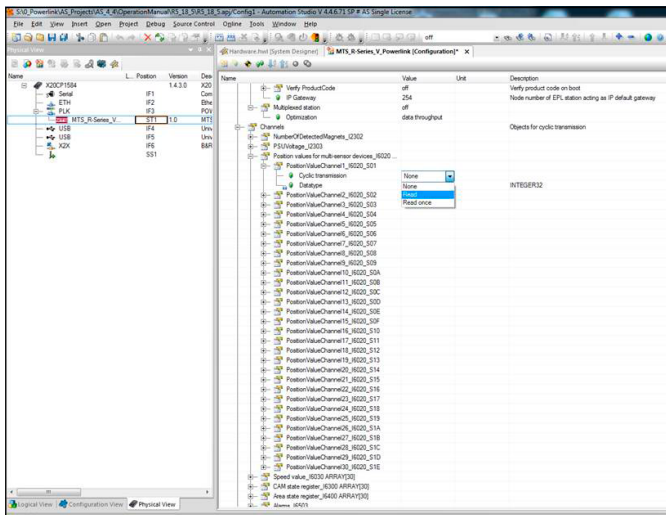

Fig. 108: Activating the mapping of the parameters of the group "Channels"

## 7.2 Communication segment

The parameters of the group “Channels” (available data items for cyclical transmission):

Index	Subindex	Name	Object type	Attribute	Data type	Description
2302		<b>Number of detected magnets</b>	Variable	rw	Unsigned8	Current number of magnets detected on the sensor
2303		<b>PSU voltage</b>	Variable	rw	Unsigned16	Current power supply in mV
6020		<b>Position values for multi-sensor devices</b>	Array			Current position value of up to 30 magnets
	0	Number of entries	Variable	ro	Unsigned8	
	1...30	Position value for magnets 1...30	Variable	ro	Integer32	
6030		<b>Speed value</b>	Array			Current velocity value of up to 30 magnets
	0	Number of entries	Variable	ro	Unsigned8	
	1...30	Speed value for magnets 1...30	Variable	ro	Integer16	
6300		<b>CAM state register</b>	Array			With the sensor you can configure a CAM switch. For each magnet there is one CAM channel. Each CAM channel supports up to four CAM positions. The parameter “CAM state register” defines the status bit of the CAM in a CAM channel for up to 30 magnets
	0	Number of entries	Variable	ro	Unsigned8	• Bit value 0: CAM inactive • Bit value 1: CAM active
	1...30	CAM state register for magnets 1...30	Variable	ro	Unsigned8	
6400		<b>Area state register</b>	Array			This object contains the actual area status of the encoder position for up to 30 magnets. If the position is out of range, a bit will be set in the related position line
	0	Number of entries	Variable	ro	Unsigned8	
	1...30	Area state register for magnets 1...30	Variable	ro	Unsigned8	
6503		<b>Alarms</b>	Variable	rw	Unsigned16	This parameter includes different alarms: • Bit 0: The number of magnets detected on the sensor differs from the number of magnets configured in the engineering tool (index 2201 subindex 0) • Bit 12: Power supply out of range • Bit 13: Device error <b>Note: To output alarms the operating parameter “commissioning diagnostic control” (object 6000) must be activated.</b>
6505		<b>Warnings</b>	Variable	rw	Unsigned16	Bit 12: Synchronization error: Sensor is not synchronized to the clock of the control <b>Note: To output warnings the parameter “commissioning diagnostic control” (object 6000) must be activated.</b>

Table 1: Index 2302, 2303, 6020, 6030, 6300, 6400, 6503, 6505

The parameters of the group “Device Specific Parameters”:

Index	Subindex	Name	Object type	Attribute	Data type	Description
2201		<b>Number of magnets</b>	Variable	rw	Unsigned8	Setting the number of position magnets that are used simultaneously on the measuring rod/profile <b>Note: If the number is greater than in the order code, an alarm is issued.</b>
2202		<b>Filter settings</b>	Array			Setting the filter for the output value
	0	Number of entries	Variable	ro	Unsigned8	
	1	Filter type	Variable	rw	Unsigned8	Setting the filter for the output value • Bit value 0: No filter • Bit value 1: FIR (finite impulse response filter) • Bit value 2: IIR (infinite impulse response filter)
	2	Filter window size	Variable	rw	Unsigned8	Setting the number of position values for calculating the filter of the output value Possible values: 2...16
	3	Velocity window size	Variable	rw	Unsigned8	Setting the number of position values for determining the velocity of the position magnet Possible values: 2...16
2203		<b>Position offsets</b>	Array			Position offset for up to 30 magnets
	0	Number of entries	Variable	ro	Unsigned8	
	1...30	Position offset for magnets 1...30	Variable	rw	Integer32	
2204		<b>Lower limit for measurement cycle time</b>	Variable	rw	Unsigned32	Setting the lower limit for the cycle time. If no short cycle time is required, reflections can be excluded with this parameter
2305		<b>Sensor status</b>				
	0	Number of entries	Variable	ro	Unsigned8	
	1	Time since last update	Variable	ro	Integer32	Age of the status data in ms
	2	Status data version	Variable	ro	Integer32	Version number
	3	Operational time	Variable	ro	Integer32	Total operational time of the sensor
	4	Odometer	Variable	ro	Integer32	Total distance travelled by the position magnet
	5	Magnet cycles	Variable	ro	Integer32	Total number of directional changes of the magnet
	6	Minimum input voltage	Variable	ro	Integer32	Minimum input voltage so far
	7	Maximum input voltage	Variable	ro	Integer32	Maximum input voltage so far
	8	Minimum temperature	Variable	ro	Integer32	Minimum temperature inside sensor electronics housing so far
	9	Maximum temperature	Variable	ro	Integer32	Maximum temperature inside sensor electronics housing so far
	10	Current temperature	Variable	ro	Integer32	Current temperature inside sensor electronics housing
	11	Input voltage out of range	Variable	ro	Integer32	Duration of exceeding or falling below the permissible power supply range
	12	Temperature out of range	Variable	ro	Integer32	Duration of exceeding or falling below the permissible operating temperature range
6000		<b>Operating parameters</b>		rw	Unsigned16	See table 5, page 71
6002		<b>Total measuring range in measuring units</b>	Variable	rw	Unsigned32	If the scaling function is activated (see object 6000: Operating parameters), this parameter includes the maximum value
6005		<b>Linear encoder measuring step settings</b>	Array			
	1	Position step setting	Variable	rw	Unsigned32	Resolution of the position output in nm
	2	Speed step setting	Variable	rw	Unsigned32	Resolution of the velocity output in 0.01 mm/s

Table 2: Index 2201, 2202, 2203, 2204, 2305, 6000, 6002, 6005

Index	Subindex	Name	Object type	Attribute	Data type	Description
6010		<b>Preset values for multi-sensor devices</b>	Array			The preset can be set for up to 30 magnets.
	0	Number of entries	Variable	ro	Unsigned8	
	1...30	Preset for 1...30 magnets	Variable	rw	Integer32	
6301		<b>CAM enable register</b>	Array			Via the "CAM enable register" the CAM channels can be enabled: • Bit value 0: CAM inactive • Bit value 1: CAM active It can be set for up to 30 magnets.
	0	Number of entries	Variable	ro	Unsigned8	
	1...30	CAM enable register for 1...30 magnets	Variable	rw	Unsigned8	
6302		<b>CAM enable polarity</b>	Array			With "CAM enable polarity", the polarity of each CAM can be definated. If the polarity bit of a CAM is set, the current CAM state will be inverted. It can be set for up to 30 magnets.
	0	Number of entries	Variable	ro	Unsigned8	
	1...30	CAM enable polarity for 1...30 magnets	Variable	rw	Unsigned8	
6310		<b>CAM 1 low limit</b>	Array			This object determines the lower limit of position for CAM 1. It can be set for up to 30 magnets.
	0	Number of entries	Variable	ro	Unsigned8	
	1...30	CAM 1 low limit for 1...30 magnets	Variable	rw	Integer32	
6311		<b>CAM 2 low limit</b>	Array			This object determines the lower limit of position for CAM 2. It can be set for up to 30 magnets.
	0	Number of entries	Variable	ro	Unsigned8	
	1...30	CAM 2 low limit for 1...30 magnets	Variable	rw	Integer32	
6312		<b>CAM 3 low limit</b>	Array			This object determines the lower limit of position for CAM 3. It can be set for up to 30 magnets.
	0	Number of entries	Variable	ro	Unsigned8	
	1...30	CAM 3 low limit for 1...30 magnets	Variable	rw	Integer32	
6313		<b>CAM 4 low limit</b>	Array			This object determines the lower limit of position for CAM 4. It can be set for up to 30 magnets.
	0	Number of entries	Variable	ro	Unsigned8	
	1...30	CAM 4 low limit for 1...30 magnets	Variable	rw	Integer32	
6320		<b>CAM 1 high limit</b>	Array			This object determines the upper limit of position for CAM 1. It can be set for up to 30 magnets.
	0	Number of entries	Variable	ro	Unsigned8	
	1...30	CAM 1 high limit for 1...30 magnets	Variable	rw	Integer32	
6321		<b>CAM 2 high limit</b>	Array			This object determines the upper limit of position for CAM 2. It can be set for up to 30 magnets.
	0	Number of entries	Variable	ro	Unsigned8	
	1...30	CAM 2 high limit for 1...30 magnets	Variable	rw	Integer32	
6322		<b>CAM 3 high limit</b>	Array			This object determines the upper limit of position for CAM 3. It can be set for up to 30 magnets.
	0	Number of entries	Variable	ro	Unsigned8	
	1...30	CAM 3 high limit for 1...30 magnets	Variable	rw	Integer32	
6323		<b>CAM 4 high limit</b>	Array			This object determines the upper limit of position for CAM 4. It can be set for up to 30 magnets.
	0	Number of entries	Variable	ro	Unsigned8	
	1...30	CAM 4 high limit for 1...30 magnets	Variable	rw	Integer32	
6330		<b>CAM 1 hysteresis</b>	Array			Via this parameter the delay setting of the switch points for CAM 1 can be set. It can be set for up to 30 magnets.
	0	Number of entries	Variable	ro	Unsigned8	
	1...30	CAM 1 hysteresis for 1...30 magnets	Variable	rw	Integer32	
6331		<b>CAM 2 hysteresis</b>	Array			Via this parameter the delay setting of the switch points for CAM 2 can be set. It can be set for up to 30 magnets.
	0	Number of entries	Variable	ro	Unsigned8	
	1...30	CAM 2 hysteresis for 1...30 magnets	Variable	rw	Integer32	

Table 3: Index 6010, 6301, 6302, 6310, 6311, 6312, 6313, 6320, 6321, 6322, 6323, 6330, 6331

Continued on [page 71](#)

Index	Subindex	Name	Object type	Attribute	Data type	Description
6332		<b>CAM 3 hysteresis</b>	Array			Via this parameter the delay setting of the switch points for CAM 3 can be set. It can be set for up to 30 magnets.
	0	Number of entries	Variable	ro	Unsigned8	
	1...30	CAM 3 hysteresis for 1...30 magnets	Variable	rw	Integer32	
6333		<b>CAM 4 hysteresis</b>	Array			Via this parameter the delay setting of the switch points for CAM 4 can be set. It can be set for up to 30 magnets.
	0	Number of entries	Variable	ro	Unsigned8	
	1...30	CAM 4 hysteresis for 1...30 magnets	Variable	rw	Integer32	
6401		<b>Work area low limit</b>	Array			This object contains the position value, at which bit 2 of the according p406_work_area_state_channel in object 6400h (Working Area State Register) flags the underflow of the related work area
	0	Number of entries	Variable	ro	Unsigned8	
	1...30	Work area low limit for 1...30 magnets	Variable	rw	Integer32	
6402		<b>Work area high limit</b>	Array			This object contains the position value, at which bit 1 of the according p406_work_area_state_channel in object 6400h (Working Area State Register) flags the overflow of the related work area
	0	Number of entries	Variable	ro	Unsigned8	
	1...30	Work area high limit for 1...30 magnets	Variable	rw	Integer32	

Table 4: Index 6332, 6333, 6401, 6402

## Operating parameters

Index	Subindex	Bit	Name	Attribute	Description
6000	0	1	<b>Commissioning diagnostic control</b>	0: Disabled 1: Enabled	This parameter must be enabled to send out alarms (object 6503)
		2	<b>Scaling function</b>	0: Disabled 1: Enabled	This parameter is used to change the position resolution of the encoder
		3	<b>Measuring direction</b>	0: Forward 1: Reverse	Setting the measuring direction
		12	<b>Synchronization mode</b>	0: Disabled 1: Enabled	Setting the synchronization of the sensor to the clock of the controller
		13	<b>Extrapolation</b>	0: Disabled 1: Enabled	Setting the sensor behavior in case of oversampling
		14	<b>Internal linearization</b>	0: Disabled 1: Enabled	Setup of the internal linearization

Table 5: Explanation of the operating parameters

**NOTICE**  
In order to operate the sensor in synchronous mode, the controller must be set so that the tasks are executed synchronously in the POWERLINK cycle. In synchronous mode, the sensor supports a bus cycle time of 200 µs. If the extrapolation is disabled, identical values can be output repeatedly. For a multi-position measurement (number of magnets ≥ 2) in synchronous mode, the minimum bus cycle time of the sensor is 400 µs.

## 8. Maintenance and troubleshooting

### 8.1 Error conditions, troubleshooting

See chapter “5. Commissioning” on page 56.

### 8.2 Maintenance

The sensor is maintenance-free.

### 8.3 Repair

Repairs of the sensor may be performed only by Temposonics or a repair facility explicitly authorized by Temposonics. For return see section “2.6 Return” on page 5.

### 8.4 List of spare parts

No spare parts are available for this sensor.

### 8.5 Transport and storage

The conditions of transport and storage of the sensor match the operating conditions mentioned in this document.

## 9. Removal from service/dismantling

The product contains electronic components and must be disposed of in accordance with the local regulations.

## 10. Technical data

### 10.1 Technical data of Temposonics® RP5

Output							
Interface	Ethernet POWERLINK						
Data protocol	POWERLINK V2						
Measured value	Position, velocity/option: Simultaneous multi-position and multi-velocity measurements up to 30 magnets						
Measurement parameters							
Resolution: Position	0.5...100 µm (selectable)						
Cycle time <sup>4</sup>	Stroke length	≤ 50 mm	≤ 715 mm	≤ 2000 mm	≤ 4675 mm	≤ 6350 mm	
	Cycle time	250 µs <sup>5</sup>	500 µs	1000 µs	2000 µs	2800 µs	
Linearity deviation <sup>6</sup>	Stroke length	≤ 500 mm	> 500 mm				
	Linearity deviation	≤ ±50 µm	< 0.01 % F.S.				
	Optional internal linearity: Linearity tolerance (applies for the first magnet for multi-position measurement)						
	Stroke length	25...300 mm	300...600 mm	600...1200 mm	1200...3000 mm	3000...5000 mm	5000...6350 mm
	typical	± 15 µm	± 20 µm	± 25 µm	± 45 µm	± 85 µm	± 95 µm
	maximum	± 25 µm	± 30 µm	± 50 µm	± 90 µm	± 150 µm	± 190 µm
Repeatability	< ±0.001 % F.S. (minimum ±2.5 µm) typical						
Hysteresis	< 4 µm typical						
Temperature coefficient	< 15 ppm/K typical						
Operating conditions							
Operating temperature	-40...+85 °C (-40...+185 °F)						
Humidity	90 % relative humidity, no condensation						
Ingress protection	IP67 (connectors correctly fitted)						
Shock test	150 g/11 ms, IEC standard 60068-2-27						
Vibration test	30 g/10...2000 Hz, IEC standard 60068-2-6 (excluding resonant frequencies)						
EMC test	Electromagnetic emission according to EN 61000-6-3						
	Electromagnetic immunity according to EN 61000-6-2						
	The RP5 sensors fulfill the requirements of the EMC directives 2014/30/EU and UKSI 2016 No. 1091						
Magnet movement velocity	Magnet slider: Max. 10 m/s; U-magnet: Any; block magnet: Any						
Design/Material							
Sensor electronics housing	Aluminum (painted), zinc die-cast						
Sensor profile	Aluminum						
RoHS compliance	The used materials are compliant with the requirements of EU directive 2011/65/EU and EU regulation 2015/863 as well as UKSI 2022 No. 622 with amendments						
Stroke length	25...6350 mm (1...250 in.)						
Mechanical mounting							
Mounting position	Any						
Mounting instruction	Please consult the technical drawing on <a href="#">page 14</a>						

Technical data "Electrical connection" on [page 74](#)

<sup>4/</sup> These values refer to a single position measurement

<sup>5/</sup> Minimum cycle time for multi-position measurements (number of magnets ≥ 2): 400 µs

<sup>6/</sup> With position magnet # 252 182

## Temposonics® R-Series V POWERLINK

### Operation Manual

Electrical connection	
Connection type	2 × M12 female connectors, 1 × M8 male connector or 2 × M12 female connectors, 1 × M12 male connector
Operating voltage	+12...30 VDC ±20 % (9.6...36 VDC); the RP5 sensors must be power supplied via an external Class 2 power source in accordance with the UL approval
Power consumption	Less than 4 W typical
Dielectric strength	500 VDC (DC ground to machine ground)
Polarity protection	Up to -36 VDC
Overvoltage protection	Up to 36 VDC

## 10.2 Technical data of Temposonics® RH5

Output						
Interface	Ethernet POWERLINK					
Data protocol	POWERLINK V2					
Measured value	Position, velocity/option: Simultaneous multi-position and multi-velocity measurements up to 30 magnets					
Measurement parameters						
Resolution: Position	0.5...100 µm (selectable)					
Cycle time <sup>7</sup>	Stroke length	≤ 50 mm	≤ 715 mm	≤ 2000 mm	≤ 4675 mm	≤ 7620 mm
	Cycle time	250 µs <sup>8</sup>	500 µs	1000 µs	2000 µs	3200 µs
Linearity deviation <sup>9</sup>	Stroke length	≤ 500 mm	> 500 mm			
	Linearity deviation	≤ ±50 µm	< 0.01 % F.S.			
	Optional internal linearity: Linearity tolerance (applies for the first magnet for multi-position measurement)					
	Stroke length	25...300 mm	300...600 mm	600...1200 mm		
	typical	± 15 µm	± 20 µm	± 25 µm		
	maximum	± 25 µm	± 30 µm	± 50 µm		
Repeatability	< ±0.001 % F.S. (minimum ±2.5 µm) typical					
Hysteresis	< 4 µm typical					
Temperature coefficient	< 15 ppm/K typical					
Operating conditions						
Operating temperature	-40...+85 °C (-40...+185 °F)					
Humidity	90 % relative humidity, no condensation					
Ingress protection	IP67 (connectors correctly fitted)					
Shock test	150 g/11 ms, IEC standard 60068-2-27					
Vibration test	30 g/10...2000 Hz, IEC standard 60068-2-6 (excluding resonant frequencies)/ RH5-J: 15 g/10...2000 Hz, IEC standard 60068-2-6 (excluding resonant frequencies)					
EMC test	Electromagnetic emission according to EN 61000-6-3 Electromagnetic immunity according to EN 61000-6-2 The RH5 sensors fulfill the requirements of the EMC directives 2014/30/EU and UKSI 2016 No. 1091					
Operating pressure	350 bar (5076 psi)/700 bar (10,153 psi) peak (at 10 × 1 min) for sensor rod/RH5-J: 800 bar (11,603 psi)					
Magnet movement velocity	Any					
Design/Material						
Sensor electronics housing	Aluminum (painted), zinc die-cast					
Sensor flange	Stainless steel 1.4305 (AISI 303)					
Sensor rod	Stainless steel 1.4306 (AISI 304L)/RH5-J: Stainless steel 1.4301 (AISI 304)					
RoHS compliance	The used materials are compliant with the requirements of EU directive 2011/65/EU and EU regulation 2015/863 as well as UKSI 2022 No. 622 with amendments					
Stroke length	25...7620 mm (1...300 in.)/RH5-J: 25...5900 mm (1...232 in.)					
Mechanical mounting						
Mounting position	Any					
Mounting instruction	Please consult the technical drawings on <a href="#">page 15</a> and on <a href="#">page 16</a>					

Technical data "Electrical connection" on [page 76](#)

7/ These values refer to a single position measurement

8/ Minimum cycle time for multi-position measurements (number of magnets ≥ 2): 400 µs

9/ With position magnet # 251 416-2

## Temposonics® R-Series V POWERLINK

### Operation Manual

Electrical connection	
Connection type	2 × M12 female connectors, 1 × M8 male connector or 2 × M12 female connectors, 1 × M12 male connector
Operating voltage	+12...30 VDC ±20 % (9.6...36 VDC); the RH5 sensors must be power supplied via an external Class 2 power source in accordance with the UL approval
Power consumption	Less than 4 W typical
Dielectric strength	500 VDC (DC ground to machine ground)
Polarity protection	Up to -36 VDC
Overvoltage protection	Up to 36 VDC

### 10.3 Technical data of Temposonics® RM5

Output						
Interface	Ethernet POWERLINK					
Data protocol	POWERLINK V2					
Measured value	Position, velocity/option: Simultaneous multi-position and multi-velocity measurements up to 30 magnets					
Measurement parameters						
Resolution: Position	0.5...100 µm (selectable)					
Cycle time <sup>10</sup>	Stroke length	≤ 50 mm	≤ 715 mm	≤ 2000 mm	≤ 4675 mm	≤ 7615 mm
	Cycle time	250 µs <sup>11</sup>	500 µs	1000 µs	2000 µs	3200 µs
Linearity deviation <sup>12</sup>	Stroke length	≤ 500 mm	> 500 mm			
	Linearity deviation	≤ ±50 µm	< 0.01 % F.S.			
	Optional internal linearization: Linearity tolerance (applies for the first magnet for multi-position measurement)					
	Stroke length	25...300 mm	300...600 mm	600...1200 mm		
	typical	± 15 µm	± 20 µm	± 25 µm		
	maximum	± 25 µm	± 30 µm	± 50 µm		
Repeatability	< ±0.001 % F.S. (minimum ±2.5 µm) typical					
Hysteresis	< 4 µm typical					
Temperature coefficient	< 15 ppm/K typical					
Operating conditions						
Operating temperature	-40...+85 °C (-40...+185 °F)					
Humidity	100 % relative humidity, no condensation					
Ingress protection	IP68 (3 m/180 d)/IP69					
Shock test	100 g/6 ms, IEC standard 60068-2-27					
Vibration test	10 g/10...2000 Hz, IEC 60068-2-6 (excluding resonant frequencies)					
EMC test	Electromagnetic emission according to EN 61000-6-3					
	Electromagnetic immunity according to EN 61000-6-2					
	The RM5 sensors fulfill the requirements of the EMC directives 2014/30/EU and UKSI 2016 No. 1091					
Operating pressure	350 bar (5076 psi)/700 bar (10,153 psi) peak (at 10 × 1 min) for sensor rod					
Magnet movement velocity	Any					
Design/Material						
Sensor electronics housing	Stainless steel 1.4404 (AISI 316L)					
Sensor flange	Stainless steel 1.4404 (AISI 316L)					
Sensor rod	Stainless steel 1.4404 (AISI 316L)					
RoHS compliance	The used materials are compliant with the requirements of EU directive 2011/65/EU and EU regulation 2015/863 as well as UKSI 2022 No. 622 with amendments					
Stroke length	25...7615 mm (1...299.8 in.)					
Mechanical mounting						
Mounting position	Any					
Mounting instruction	Please consult the technical drawings on <a href="#">page 18</a>					
Electrical connection						
Connection type	2 × cable with M12 female connector (D-coded), 1 × cable					
Operating voltage	+12...30 VDC ±20 % (9.6...36 VDC); the RM5 sensors must be power supplied via an external Class 2 power source in accordance with the UL approval					
Power consumption	Less than 4 W typical					
Dielectric strength	500 VDC (DC ground to machine ground)					
Polarity protection	Up to -36 VDC					
Overvoltage protection	Up to 36 VDC					

<sup>10</sup>/These values refer to a single position measurement

<sup>11</sup>/Minimum cycle time for multi-position measurements (number of magnets ≥ 2): 400 µs

<sup>12</sup>/With position magnet # 251 416-2

**10.4 Technical data of Temposonics® RF5**

Output						
Interface	Ethernet POWERLINK					
Data protocol	POWERLINK V2					
Data transmission rate	100 MBit/s (maximum)					
Measured value	Position, velocity/option: Simultaneous multi-position and multi-velocity measurements up to 30 magnets					
Measurement parameters						
Resolution: Position	0.5...100 µm (selectable)					
Cycle time <sup>13</sup>	Stroke length	≤ 715 mm	≤ 2000 mm	≤ 4675 mm	≤ 10,000 mm	≤ 20,000 mm
	Cycle time	500 µs <sup>14</sup>	1000 µs	2000 µs	4000 µs	8000 µs
Linearity deviation <sup>15</sup>	< ±0.02 % F.S. (minimum ±100 µm)					
Repeatability	< ±0.001 % F.S. (minimum ±2.5 µm) typical					
Hysteresis	< 4 µm typical					
Temperature coefficient	< 15 ppm/K typical					
Operating conditions						
Operating temperature	-40...+85 °C (-40...+185 °F)					
Humidity	90 % relative humidity, no condensation					
Ingress protection	IP68 (3 d/3 m) (connectors and flange correctly fitted)					
Shock test	100 g/6 ms, IEC standard 60068-2-27 (when guided in a support pipe, e.g. sensor rod HD/HL/HP)					
Vibration test	5 g/10...2000 Hz, IEC standard 60068-2-6 (excluding resonant frequencies) (when guided in a support pipe, e.g. sensor rod HD/HL/HP)					
EMC test	Electromagnetic emission according to EN 61000-6-3					
	Electromagnetic immunity according to EN 61000-6-2 With EMC-compliant installation, the RF5 sensors fulfill the requirements of EMC directives 2014/30/EU, and UKSI 2016 No. 1091. <sup>16</sup>					
Magnet movement velocity	Any					
Design/Material						
Sensor electronics housing	Aluminum (painted), zinc die-cast					
Sensor flange	Stainless steel 1.4305 (AISI 303)					
Sensor rod	Stainless steel conduct with PU coating					
RoHS compliance	The used materials are compliant with the requirements of EU Directive 2011/65/EU and EU Regulation 2015/863 as well as UKSI 2022 No. 622 with amendments					
Stroke length	150...20,000 mm (6...787 in.)					
Mechanical mounting						
Mounting position	Any					
Mounting instruction	Please consult the technical drawings on <a href="#">page 20</a>					
Electrical connection						
Connection type	2 × M12 female connectors (D-coded), 1 × M8 male connector or 2 × M12 female connectors (D-coded), 1 × M12 male connector (A-coded)					
Operating voltage	+12...30 VDC ±20 % (9.6...36 VDC); the RF5 sensors must be power supplied via an external Class 2 power source in accordance with the UL approval					
Power consumption	Less than 4 W typical					
Dielectric strength	500 VDC (DC ground to machine ground)					
Polarity protection	Up to -36 VDC					
Overvoltage protection	Up to 36 VDC					

<sup>13</sup>/These values refer to a single position measurement

<sup>14</sup>/Minimum cycle time for multi-position measurements (number of magnets ≥ 2): 400 µs

<sup>15</sup>/With position magnet # 251 416-2

<sup>16</sup>/The flexible sensor element must be mounted in an appropriately shielded environment

## 10.5 Technical data of Temposonics® RFV

Output						
Interface	Ethernet POWERLINK					
Data protocol	POWERLINK V2					
Measured value	Position, velocity/option: Simultaneous multi-position and multi-velocity measurements up to 30 magnets					
Measurement parameters						
Resolution: Position	0.5...100 µm (selectable)					
Cycle time <sup>17</sup>	Stroke length	≤ 715 mm	≤ 2000 mm	≤ 4675 mm	≤ 10,000 mm	≤ 20,000 mm
	Cycle time	500 µs <sup>18</sup>	1000 µs	2000 µs	4000 µs	8000 µs
Linearity deviation <sup>19</sup>	Stroke length	≤ 500 mm	> 500 mm			
	Linearity deviation	≤ ±50 µm	< 0.01 % F.S.			
Repeatability	< ±0.001 % F.S. (minimum ±2.5 µm) typical					
Hysteresis	< 4 µm typical					
Temperature coefficient	< 15 ppm/K typical					
Operating conditions						
Operating temperature	-40...+85 °C (-40...+185 °F)					
Humidity	90 % relative humidity, no condensation					
Ingress protection	IP30 (IP65 rating only for professional mounted guide pipe IP65 and if mating connectors are correctly fitted)					
Shock test	100 g/6 ms, IEC standard 60068-2-27					
Vibration test	5 g/10...2000 Hz, IEC standard 60068-2-6 (excluding resonant frequencies)					
EMC test	Electromagnetic emission according to EN 61000-6-3					
	Electromagnetic immunity according to EN 61000-6-2					
	With EMC-compliant installation, the RFV sensors fulfill the requirements of the EMC directives 2014/30/EU and UKSI 2016 No. 1091. <sup>20</sup>					
Magnet movement velocity	Any					
Design/Material						
Sensor electronics housing	Aluminum (painted), zinc die-cast					
Sensor flange	Stainless steel 1.4305 (AISI 303)					
Sensor rod	Stainless steel conduct with PTFE coating					
RoHS compliance	The used materials are compliant with the requirements of EU directive 2011/65/EU and EU regulation 2015/863 as well as UKSI 2022 No. 622 with amendments					
Stroke length	150...20,000 mm (6...787 in.)					
Mechanical mounting						
Mounting position	Any					
Mounting instruction	Please consult the technical drawings on <a href="#">page 24</a>					
Electrical connection						
Connection type	2 × M12 female connectors, 1 × M8 male connector or 2 × M12 female connectors, 1 × M12 male connector					
Operating voltage	+12...30 VDC ±20 % (9.6...36 VDC); the RFV sensors must be power supplied via an external Class 2 power source in accordance with the UL approval					
Power consumption	Less than 4 W typical					
Dielectric strength	500 VDC (DC ground to machine ground)					
Polarity protection	Up to -36 VDC					
Overvoltage protection	Up to 36 VDC					

<sup>17</sup>/These values refer to a single position measurement

<sup>18</sup>/Minimum cycle time for multi-position measurements (number of magnets ≥ 2): 400 µs

<sup>19</sup>/With position magnet # 251 416-2

<sup>20</sup>/The flexible sensor element must be mounted in an appropriately shielded environment

## 10.6 Technical data of Temposonics® RDV

Output						
Interface	Ethernet POWERLINK					
Data protocol	POWERLINK V2					
Measured value	Position, velocity/option: Simultaneous multi-position and multi-velocity measurements up to 30 magnets					
Measurement parameters						
Resolution: Position	0.5...100 µm (selectable)					
Cycle time <sup>21</sup>	Stroke length	≤ 50 mm	≤ 715 mm	≤ 2000 mm	≤ 4675 mm	5080 mm
	Cycle time	250 µs <sup>22</sup>	500 µs	1000 µs	2000 µs	3200 µs
Linearity deviation <sup>23, 24</sup>	Stroke length	≤ 500 mm	> 500 mm			
	Linearity deviation	≤ ± 50 µm	< 0.01 % F.S.			
	Optional internal linearization: Linearity tolerance (applies for the first magnet for multi-position measurement)					
	Stroke length	25...300 mm	300...600 mm	600...1200 mm		
	typical	± 15 µm	± 20 µm	± 25 µm		
	maximum	± 25 µm	± 30 µm	± 50 µm		
Repeatability	< ±0.001 % F.S. (minimum ±2.5 µm) typical					
Hysteresis	< 4 µm typical					
Temperature coefficient	< 15 ppm/K typical					
Operating conditions						
Operating temperature	-40...+85 °C (-40...+185 °F)					
Humidity	90 % relative humidity, no condensation					
Ingress protection	Sensor electronics IP67 (with professional mounted housing and connectors) Measuring rod with connecting cable for side cable entry: IP65 Measuring rod with single wires and flat connector with bottom cable entry: IP30					
Shock test	100 g/11 ms, IEC standard 60068-2-27					
Vibration test	10 g/10...2000 Hz, IEC standard 60068-2-6 (excluding resonant frequencies)					
EMC test	Electromagnetic emission according to EN 61000-6-3					
	Electromagnetic immunity according to EN 61000-6-2					
	With EMC-compliant installation, the RDV sensors fulfill the requirements of the EMC directives 2014/30/EU and UKSI 2016 No. 1091. <sup>25</sup>					
Operating pressure	350 bar (5076 psi)/700 bar (10,153 psi) peak (at 10 × 1 min) for sensor rod					
Magnet movement velocity	Any					
Design/Material						
Sensor electronics housing	Aluminum (painted), zinc die-cast					
Sensor rod with flange	Stainless steel 1.4301 (AISI 304)					
RoHS compliance	The used materials are compliant with the requirements of EU directive 2011/65/EU and EU regulation 2015/863 as well as UKSI 2022 No. 622 with amendments					
Stroke length	25...2540 mm (1...100 in.) for pressure-fit flange »S«					
	25...5080 mm (1...200 in.) for all threaded flanges					
Mechanical mounting						
Mounting position	Any					
Mounting instruction	Please consult the technical drawings on <a href="#">page 28</a> and on <a href="#">page 29</a>					

Technical data "Electrical connection" on [page 81](#)

<sup>21</sup>/These values refer to a single position measurement

<sup>22</sup>/Minimum cycle time for multi-position measurements (number of magnets ≥ 2): 400 µs

<sup>23</sup>/With position magnet # 251 416-2

<sup>24</sup>/For rod style »S« the linearity deviation can be higher in the first 30 mm (1.2 in.) of stroke length

<sup>25</sup>/The cable between the sensor element and the electronic housing must be mounted in an appropriately shielded environment

Electrical connection	
Connection type	2 × M12 female connectors, 1 × M8 male connector or 2 × M12 female connectors, 1 × M12 male connector
Operating voltage	+12...30 VDC ±20 % (9.6...36 VDC); the RDV sensors must be power supplied via an external Class 2 power source in accordance with the UL approval
Power consumption	Less than 4 W typical
Dielectric strength	500 VDC (DC ground to machine ground)
Polarity protection	Up to -36 VDC
Overvoltage protection	Up to 36 VDC

## 11. Appendix I – Safety declaration

Dear Customer,

If you return one or several sensors for checking or repair, we need you to sign a safety declaration. The purpose of this declaration is to ensure that the returned items do not contain residues of harmful substances and/or that people handling these items will not be in danger.

Temposonics order code: \_\_\_\_\_ Sensor model(s): \_\_\_\_\_  
 Serial number(s): \_\_\_\_\_ Stroke length(s): \_\_\_\_\_

**The sensor has been in contact with the following materials:**

Do not specify chemical formulas.  
 Please include safety data sheets of the substances, if applicable.

In the event of suspected penetration of substances into the sensor, consult Temposonics to determine measures to be taken before shipment.

**Short description of malfunction:**

**Corporate information**

Company: \_\_\_\_\_  
 Address: \_\_\_\_\_  
 \_\_\_\_\_

**Contact partner**

Phone: \_\_\_\_\_  
 Fax: \_\_\_\_\_  
 Email: \_\_\_\_\_

We hereby certify that the measuring equipment has been cleaned and neutralized.  
 Equipment handling is safe. Personnel exposure to health risks during transport and repair is excluded.

Stamp

Signature

Date

**Temposonics, LLC** Tel. +1 919 677-0100  
 3001 Sheldon Drive Fax +1 (919) 677-0200  
 Cary, N.C. 27513 info.us@temposonics.com  
 United States www.temposonics.com

**Temposonics GmbH & Co.KG** Tel. +49 2351/95 87-0  
 Auf dem Schüffel 9 Fax. +49 2351/56 49 1  
 58513 Lüdenscheid info.de@temposonics.com  
 Germany www.temposonics.com

## 12. Appendix II – Cylinder port details

### PORT DETAIL (PD) FOR RH5-S:

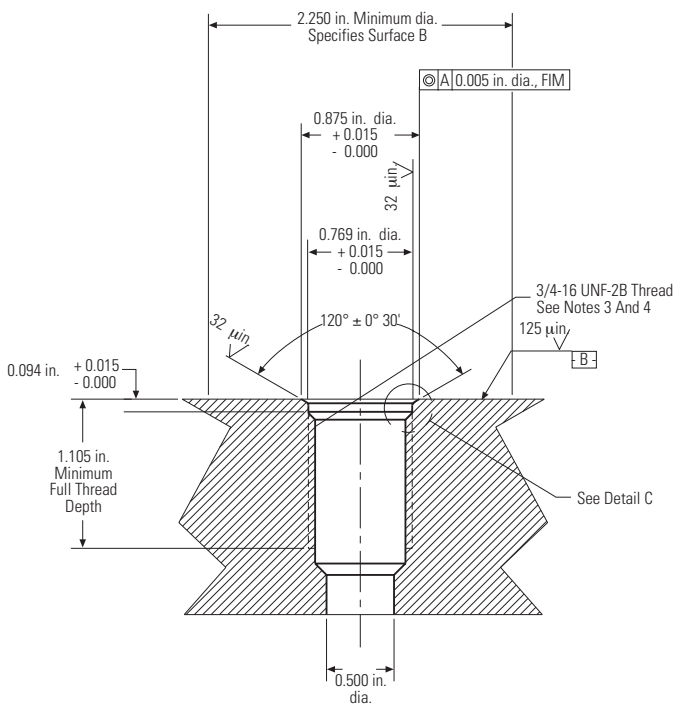

#### NOTES:

1. Dimensions and tolerances based on ANSI Y14.5-1982.
2. Temposonics has extracted all pertinent information from MS33649 to generate this document.
3. PD must be square with surface B within 0.005 FIM across 2.250 dia minimum.
4. PD must be concentric with 2.250 dia within 0.030 FIM and with 0.769 dia within 0.005 FIM.
5. Surface texture ANSI B46.1-1978
6. Use O-ring part number 560315 for correct sealing.
7. The thread design shall have sufficient threads to meet strength requirements of material used.
8. Finish counter-bore shall be free from longitudinal and spiral tool marks. Annular tool marks up to 32 microinches maximum will be permissible.

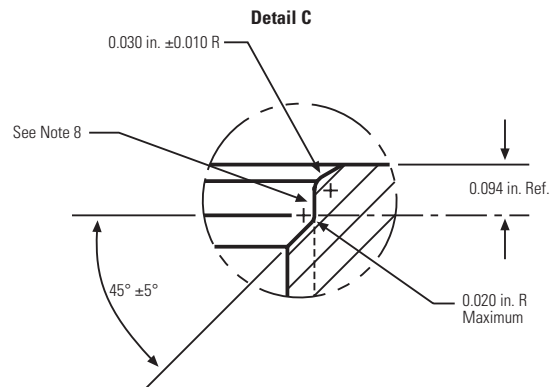

### PORT DETAIL (PD) FOR RH5-T:

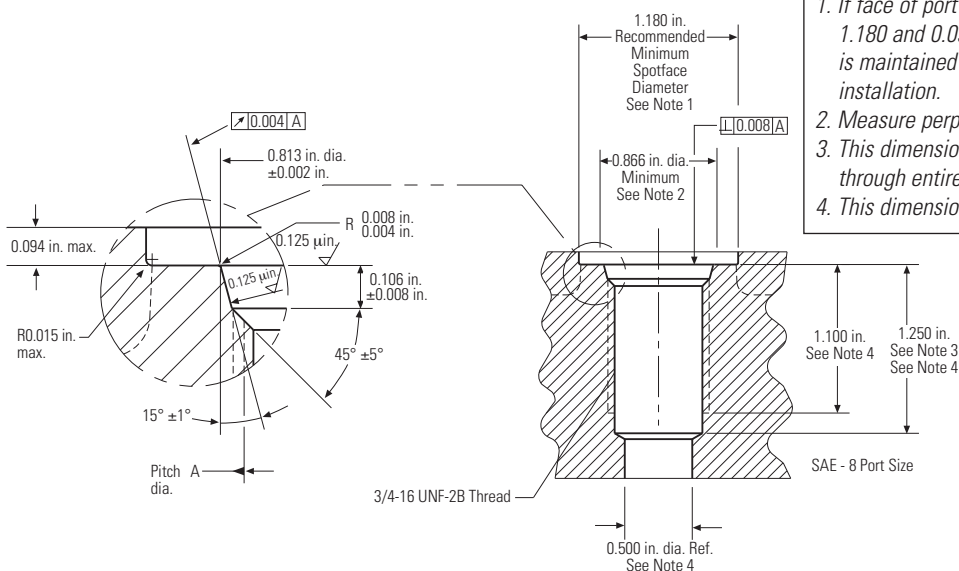

#### NOTES:

1. If face of port is on a machined surface, dimensions 1.180 and 0.094 need not apply as long as R0.008/0.004 is maintained to avoid damage to the O-ring during installation.
2. Measure perpendicularity to A at this diameter.
3. This dimension applies when tap drill cannot pass through entire boss.
4. This dimension does not conform to SAE J1926/1.

## 13. Glossary

### C

#### CAM

Cam position of a CAM channel in a cam gear. Each CAM position can be configured separately. With R-Series V POWERLINK, for each position magnet there is one CAM channel. Each CAM channel supports up to four CAM positions.

#### Controlled Node (CN)

All devices in the network, except the Managing Node, are **Controlled Nodes (CN)**. The Controlled Nodes may send their data only after being requested by the Managing Node. The R-Series V POWERLINK can only be used as a Controlled Node. (→ Managing Node)

### E

#### Extrapolation

The native measurement cycle time of a sensor increases with the stroke length. With extrapolation, the sensor is able to report data faster than the native cycle time, independent of the stroke length of the sensor. Without extrapolation, if data is requested faster than the native cycle time, the last measured value is repeated.

### F

#### FIR Filter

The FIR filter (**Finite Impulse Response**) is used to smooth the measured position value before output. To determine the output value, only input values corresponding to the window (filter window size) are used for filter calculation. The output value is calculated from these input values in form of a moving average value. (→ IIR Filter)

### I

#### I/O Mapping

I/O mapping is used to configure the cyclical data that is transferred between sensor and controller. The assignment of the inputs (**IN**) and outputs (**OUT**) is done from the perspective of the controller. Cyclical data from the sensor to the controller are, for example, the position and the velocity.

#### IIR Filter

The IIR filter (**Infinite Impulse Response**) is used to smooth the measured position value before output. To determine the output value, the input values corresponding to the filter grade (filter window size) are used for the filter calculation. The previous values are also taken into account when calculating the output value. (→ FIR Filter)

#### Internal Linearization

The internal linearization offers an improved linearity for an overall higher accuracy of the position measurement. The internal linearization is set for the sensor during production.

### M

#### Managing Node (MN)

The **Managing Node (MN)**, usually an industrial PC or a PLC, controls the communication in the network as master and sets the clock for the synchronization of all devices. In a network there is only one Managing Node. All other devices of the POWERLINK network are Controlled Nodes. (→ Controlled Node)

#### Measuring direction

When moving the position magnet, the position and velocity values increase in the measuring direction.

- Forward: Values increasing from sensor electronics housing to rod end/profile end
- Reverse: Values decreasing from sensor electronics housing to rod end/profile end

#### Multi-position measurement

During the measurement cycle, the positions of every magnet on the sensor are simultaneously reported. The velocity is continuously calculated based on these changing position values as the magnets are moved.

### N

#### Node ID

The addressing of the devices in a POWERLINK network is done via the node ID. Each node ID only exists once in a network. It can have a value between 1 and 240 (while 240 is reserved for the Managing Node). Meaning that a POWERLINK network can comprise up to 240 devices. With the R-Series V POWERLINK, the node ID (delivered with node ID 1) can be set via the TempoLink® smart assistant, for example.

### O

#### Offset

A value which will be added or deducted to the actual position value. This leads to a shift of the measurement range start. (→ Preset)

### P

#### POWERLINK

POWERLINK is an Industrial Ethernet interface and is managed by the **Ethernet POWERLINK Standardization Group (EPSG)**. The R-Series V POWERLINK and its corresponding XDD file are certified by the EPSG.

#### PLC

A PLC (**Programmable Logic Controller**) is a device for controlling or regulating machines and systems.

#### Preset

With the preset, a value is entered for the current position which is to be output at this position in the future. The difference between the entered value and the currently measured position is calculated as an offset. (→ Offset)

### R

#### RO

RO (**Read Only**) means that the value of the variable can only be read but is not modifiable.

#### RW

RW (**Read/Write**) means that the value of the variable can be read and written. The value of the variable is modifiable.

## S

### **Synchronization mode**

R-Series V POWERLINK supports synchronization mode. The synchronization mode enables clock-synchronous data exchange between sensor and control. The synchronous measurement is an essential requirement for motion-controlled applications

## V

### **Vendor ID**

A unique identification number (ID) assigned to each piece of computer hardware.

## X

### **XDD file**

The properties and functions of a POWERLINK device are described in a XDD file (**X**ML **D**evice **D**escription). The XML-based XDD file contains all relevant data that are important for the implementation of the device in the controller as well as for data exchange during operation. The XDD file of the R-Series V POWERLINK is available on the homepage [www.temposonics.com](http://www.temposonics.com).

**UNITED STATES**  
**Temposonics, LLC**  
Americas & APAC Region  
3001 Sheldon Drive  
Cary, N.C. 27513  
Phone: +1 919 677-0100  
E-mail: [info.us@temposonics.com](mailto:info.us@temposonics.com)

**GERMANY**  
**Temposonics**  
**GmbH & Co. KG**  
EMEA Region & India  
Auf dem Schüffel 9  
58513 Lüdenscheid  
Phone: +49 2351 9587-0  
E-mail: [info.de@temposonics.com](mailto:info.de@temposonics.com)

**ITALY**  
Branch Office  
Phone: +39 030 988 3819  
E-mail: [info.it@temposonics.com](mailto:info.it@temposonics.com)

**FRANCE**  
Branch Office  
Phone: +33 6 14 060 728  
E-mail: [info.fr@temposonics.com](mailto:info.fr@temposonics.com)

**UK**  
Branch Office  
Phone: +44 79 21 83 05 86  
E-mail: [info.uk@temposonics.com](mailto:info.uk@temposonics.com)

**SCANDINAVIA**  
Branch Office  
Phone: +46 70 29 91 281  
E-mail: [info.sca@temposonics.com](mailto:info.sca@temposonics.com)

**CHINA**  
Branch Office  
Phone: +86 21 3405 7850  
E-mail: [info.cn@temposonics.com](mailto:info.cn@temposonics.com)

**JAPAN**  
Branch Office  
Phone: +81 3 6416 1063  
E-mail: [info.jp@temposonics.com](mailto:info.jp@temposonics.com)

**Document Part Number:**  
552010 Revision E (EN) 05/2026



ETHERNET   
**POWERLINK**  
certified product

**temposonics.com**