

# Operation Manual

## **E-Series CANopen** Magnetostrictive Linear Position Sensors

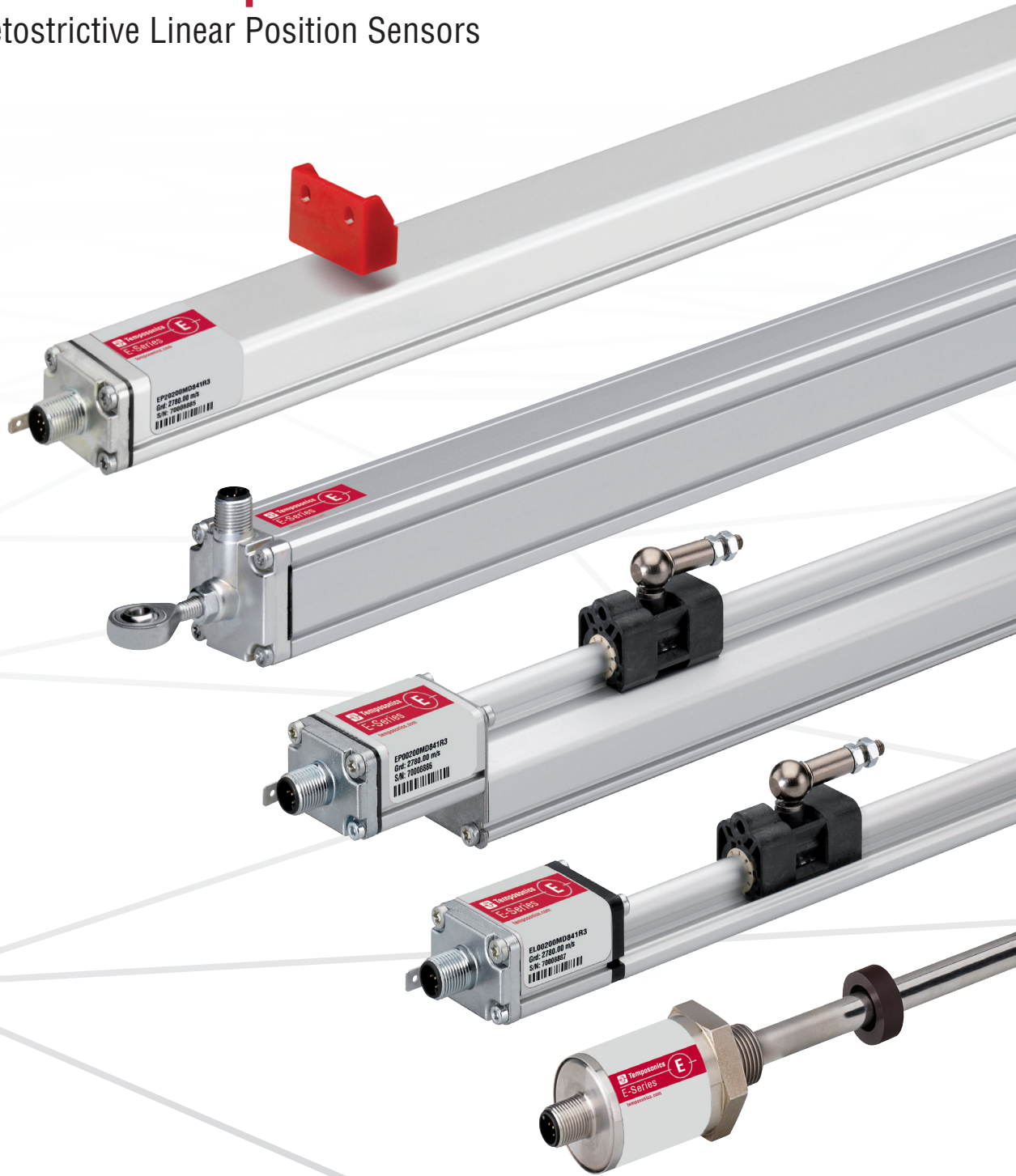

## Table of contents

<b>1. Introduction</b>	<b>3</b>
1.1 Purpose and use of this manual	3
1.2 Used symbols and warnings	3
<b>2. Safety instructions</b>	<b>3</b>
2.1 Intended use	3
2.2 Forseeable misuse	3
2.3 Installation, commissioning and operation	4
2.4 Safety instructions for use in explosion-hazardous areas	4
2.5 Warranty	4
2.6 Return	4
<b>3. Identification</b>	<b>5</b>
3.1 Order code of Temposonics® EH	5
3.2 Order code of Temposonics® EP/EL	6
3.3 Order code of Temposonics® EP2	7
3.4 Order code of Temposonics® ER	8
3.5 Nameplate	9
3.6 Approvals	9
3.7 Scope of delivery	9
<b>4. Product description and commissioning</b>	<b>10</b>
4.1 Functionality and system design	10
4.2 Installation and design of Temposonics® EH	11
4.3 Installation and design of Temposonics® EP/EL	13
4.4 Installation and design of Temposonics® EP2	14
4.5 Installation and design of Temposonics® ER	15
4.6 Magnet installation	16
4.7 Electrical connections	19
4.8 Frequently ordered accessories for Temposonics® EH	20
4.9 Frequently ordered accessories for Temposonics® EP/EL	21
4.10 Frequently ordered accessories for Temposonics® EP2	22
4.11 Frequently ordered accessories for Temposonics® ER	23
4.12 Frequently ordered accessories for CANopen output	24
<b>5. Commissioning</b>	<b>25</b>
5.1 Encoder functionality system description	25
5.2 Encoder installations configuration of node parameters	26
5.3 Configuration of process parameters	26
5.4 CANopen Network Management (NMT)	27
5.5 Configuration	29
5.6 Programming parameter	33
5.7 Process data	41
<b>6. Maintenance and troubleshooting</b>	<b>43</b>
6.1 Error conditions, troubleshooting	43
6.2 Maintenance	43
6.3 Repair	43
6.4 List of spare parts	43
6.5 Transport and storage	43
<b>7. Removal from service/dismantling</b>	<b>43</b>
<b>8. Technical data</b>	<b>44</b>
8.1 Technical data of Temposonics® EH	44
8.2 Technical data of Temposonics® EP/EL	45
8.3 Technical data of Temposonics® EP2	46
8.4 Technical data of Temposonics® ER	47
<b>9. Appendix – Safety declaration</b>	<b>48</b>

## 1. Introduction

### 1.1 Purpose and use of this manual

Before starting the operation of Temposonics® position sensors, read this documentation thoroughly and follow the safety information. Keep this manual for future reference!

The content of this technical documentation and of its appendix is intended to provide information on mounting, installation and commissioning by qualified automation personnel <sup>1</sup> or instructed service technicians who are familiar with the project planning and dealing with Temposonics sensors.

### 1.2 Used symbols and warnings

Warnings are intended for your personal safety and for avoidance of damage to the described product or connected devices. In this documentation, safety information and warnings to avoid dangers that might affect the life and health of operating or service personnel or cause material damage are highlighted by the pictogram defined below.

Symbol	Meaning
<b>NOTICE</b>	This symbol is used to point to situations that may lead to material damage, but not to personal injury.

## 2. Safety instructions

### 2.1 Intended use

This product may be used only for the applications defined under item 1 and only in conjunction with the third-party devices and components recommended or approved by Temposonics. As a prerequisite of proper and safe operation the product requires correct transport, storage, mounting and commissioning and must be operated with utmost care.

- The sensor systems of all Temposonics® series are intended exclusively for measurement tasks encountered in industrial, commercial and laboratory applications. The sensors are considered as system accessories and must be connected to suitable evaluation electronics, e.g. a PLC, IPC, indicator or other electronic control unit.

<sup>1/</sup> The term "qualified technical personnel" characterizes persons who:

- are familiar with the safety concepts of automation technology applicable to the particular project
- are competent in the field of electromagnetic compatibility (EMC)

### 2.2 Foreseeable misuse

Foreseeable misuse	Consequence
Wrong sensor connection	The sensor will not work properly or can be damaged
Operate the sensor out of the operating temperature range	No signal output – the sensor can be damaged
Power supply is out of the defined range	Signal output is wrong/ no signal output/ the sensor will be damaged
Position measurement is influenced by an external magnetic field	Signal output is wrong
Cables are damaged	Short circuit – the sensor can be damaged/sensor does not respond
Spacers are missing/ installed in a wrong order	Error in position measurement
Wrong connection of ground/shield	Signal output is disturbed – the electronics can be damaged
Use of a magnet that is not specified by Temposonics	Error in position measurement

**Do not alter the sensor afterwards.**  
→ The sensor might be damaged.

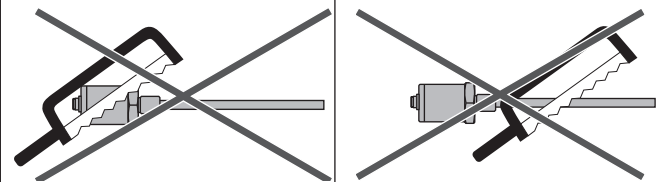

**Do not step on the sensor.**  
→ The sensor might be damaged.

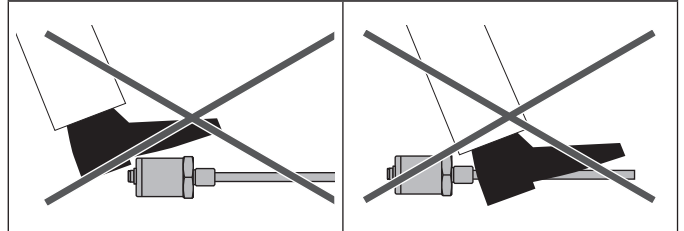

- have received adequate training for commissioning and service operations
- are familiar with the operation of the device and know the information required for correct operation provided in the product documentation

## 2.3 Installation, commissioning and operation

The position sensors must be used only in technically safe condition. To maintain this condition and to ensure safe operation, installation, connection and service, work may be performed only by qualified technical personnel. If danger of injury to persons or of damage to operating equipment is caused by sensor failure or malfunction, additional safety measures such as plausibility checks, limit switches, EMERGENCY STOP systems, protective devices etc. are required. In the event of trouble, shut down the sensor and protect it against accidental operation.

### Safety instructions for commissioning

To maintain the sensor's operability, it is mandatory to follow the instructions given below.

1. Protect the sensor against mechanical damage during installation and operation.
2. Do not open or dismantle the sensor.
3. Connect the sensor very carefully and pay attention to the polarity of connections and power supply.
4. Use only approved power supplies.
5. It is indispensable to ensure that the specified permissible limit values of the sensor for operating voltage, environmental conditions, etc. are met.
6. Check the function of the sensor regularly and provide documentation of the checks.
7. Before applying power, ensure that nobody's safety is jeopardized by starting machines.

## 2.4 Safety instructions for use in explosion-hazardous areas

The sensor is not suitable for operation in explosion-hazardous areas.

## 2.5 Warranty

Temposonics grants a warranty period<sup>2</sup> for its position sensors and supplied accessories relating to material defects and faults that occur despite correct use in accordance with the intended application. The Temposonics obligation is limited to repair or replacement of any defective part of the unit. No warranty can be provided for defects that are due to improper use or above average stress of the product as well as for wear parts. Under no circumstances will Temposonics accept liability in the event of offense against the warranty rules, no matter if these have been assured or expected, even in case of fault or negligence of the company.

Temposonics explicitly excludes any further warranties. Neither the company's representatives, agents, dealers nor employees are authorized to increase or change the scope of warranty.

## 2.6 Return

For diagnostic purposes, the sensor can be returned to Temposonics. Any shipment cost is the responsibility of the sender<sup>2</sup>. For a corresponding form, see chapter "9. Appendix – Safety declaration" on page 48

### NOTICE

When returning sensors, place protective caps on male and female connectors of the sensor. For pigtail cables, place the cable ends in a static shielding bag for electrostatic discharge (ESD) protection. Fill the outer packaging around the sensor completely to prevent damage during transport.

2/ See also applicable Temposonics terms of sales and delivery on:  
[www.temposonics.com](http://www.temposonics.com)

### 3. Identification

#### 3.1 Order code of Temposonics® EH

1	2	3	4	5	6	7	8	9	10	11	12	13	14	15	16	17	18	19	20	21	22		
E	H										1	C						1					
a	b	c						d			e	f					g	h	i	j			
optional																							

a	Sensor model
E H	Rod

b	Design
<b>EH rod-style sensor with housing material 1.4305 (AISI 303) and rod material 1.4301 (AISI 304)</b>	
K	Threaded flange M18×1.5-6g, Ø 7 mm rod
L	Threaded flange ¾"-16 UNF-3A, Ø 7 mm rod
<b>EH rod-style sensor with housing material 1.4305 (AISI 303) and rod material 1.4306 (AISI 304L)</b>	
M	Threaded flange M18×1.5-6g, Ø 10 mm rod
S	Threaded flange ¾"-16 UNF-3A, Ø 10 mm rod
<b>EH rod-style sensor with housing material 1.4404 (AISI 316L) and rod material 1.4404 (AISI 316L)</b>	
F	Threaded flange ¾"-16 UNF-3A, Ø 10 mm rod
W	Threaded flange M18×1.5-6g, Ø 10 mm rod

c	Stroke length
X X X X M	0050...2540 mm
Standard stroke length (mm)      Ordering steps	
50... 500 mm	5 mm
500... 750 mm	10 mm
750... 1000 mm	25 mm
1000... 2540 mm	50 mm
X X X X U	002.0...100.0 in.
Standard stroke length (in.)      Ordering steps	
2... 20 in.	0.2 in.
20... 30 in.	0.4 in.
30... 40 in.	1.0 in.
40... 100 in.	2.0 in.
Non-standard stroke lengths are available; must be encoded in 5 mm/0.1 in. increments.	

NOTICE	
<ul style="list-style-type: none"> <li>The number of magnets is limited by the stroke length. The minimum allowed distance between magnets (i.e. front face of one to the front face of the next one) is 75 mm (3 in.).</li> <li>Use magnets of the same type for multi-position measurement.</li> </ul>	

d	Connection type
D 3 4	M12 male connector (5 pin)

e	Operating voltage
1	+24 VDC (-15/+20 %)

f	Output
C 3 0 4	CANopen
C 4 0 4	CANopen (bus terminator)

g	Baud rate
1	1000 kBit/s
2	500 kBit/s
3	250 kBit/s
4	125 kBit/s

h	Resolution
4	10 µm
5	20 µm

i	Type
1	Standard

j	Number of magnets for multi-position measurement (optional)
Z 0 2	2 Positions (2 magnets)

\*/ Available on request, minimum quantity 25 pieces

### 3.2 Order code of Temposonics® EP/EL

1	2	3	4	5	6	7	8	9	10	11	12	13	14	15	16	17	18	19	20	21	22
E		0						D	3	4	1	C						1			
a		b	c					d			e	f				g	h	i	j		
optional																					

a Sensor model		
E	P	Ultra low profile
E	L	Compact profile

b Design	
0	Without position magnet

c Stroke length					
X	X	X	X	M	0050...2540 mm
Standard stroke length (mm)		Ordering steps			
50... 500 mm		25 mm			
500...2540 mm		50 mm			

X	X	X	X	U	002.0...100.0 in.
Standard stroke length (in.)		Ordering steps			
2... 20 in.		1.0 in.			
20...100 in.		2.0 in.			

Non-standard stroke lengths are available; must be encoded in 5 mm/0.1 in. increments.

d Connection type			
D	3	4	M12 male connector (5 pin)

e Operating voltage	
1	+24 VDC (-15/+20 %)

f Output				
C	3	0	4	CANopen
C	4	0	4	CANopen (bus terminator)

g Baud rate	
1	1000 kBit/s
2	500 kBit/s
3	250 kBit/s
4	125 kBit/s

h Resolution	
4	10 µm
5	20 µm

i Type	
1	Standard

j Number of magnets for multi-position measurement (optional)			
Z	0	2	2 Positions (2 magnets)

#### NOTICE

- The number of magnets is limited by the stroke length. The minimum allowed distance between magnets (i.e. front face of one to the front face of the next one) is 75 mm (3 in.).
- Use magnets of the same type for multi-position measurement.

### 3.3 Order code of Temposonics® EP2

1	2	3	4	5	6	7	8	9	10	11	12	13	14	15	16	17	18	19	20	21	22	
E	P	2						D	3	4	1	C						1				
a			b					c			d	e				f	g	h	i			
																				optional		

<b>a</b>	<b>Sensor model</b>		
E	P	2	Smooth profile

<b>b</b>	<b>Stroke length</b>				
X	X	X	X	M	0050...2540 mm

Standard stroke length (mm)	Ordering steps
50... 500 mm	25 mm
500...2540 mm	50 mm

X	X	X	X	U	002.0...100.0 in.
---	---	---	---	---	-------------------

Standard stroke length (in.)	Ordering steps
2... 20 in.	1.0 in.
20...100 in.	2.0 in.

Non-standard stroke lengths are available; must be encoded in 5 mm/0.1 in. increments.

<b>c</b>	<b>Connection type</b>		
D	3	4	M12 male connector (5 pin)

<b>d</b>	<b>Operating voltage</b>
1	+24 VDC (-15/+20 %)

<b>e</b>	<b>Output</b>			
C	3	0	4	CANopen
C	4	0	4	CANopen (bus terminator)

<b>f</b>	<b>Baud rate</b>
1	1000 kBit/s
2	500 kBit/s
3	250 kBit/s
4	125 kBit/s

<b>g</b>	<b>Resolution</b>
4	10 µm
5	20 µm

<b>h</b>	<b>Type</b>
1	Standard

<b>i</b>	<b>Number of magnets for multi-position measurement (optional)</b>		
Z	0	2	2 Positions (2 magnets)

**NOTICE**

- The number of magnets is limited by the stroke length. The minimum allowed distance between magnets (i.e. front face of one to the front face of the next one) is 75 mm (3 in.).
- Use magnets of the same type for multi-position measurement.
- Align all block magnets for a multi-position measurement so that the air gap of all magnets has the same height.

### 3.4 Order code of Temposonics® ER

1	2	3	4	5	6	7	8	9	10	11	12	13	14	15	16	17	18	19
E	R							D	3	4	1	C						1
a		b	c					d			e	f				g	h	i

a	Sensor model
E R	Aluminum cylinder with a guided driving rod

b	Design
M	Inside thread M6 at end of rod (For metric stroke length measurement)
S	Inside thread 1/4"-28 UNF at end of rod (For US customary stroke length measurement)

c	Stroke length
X X X X M	0050...1500 mm
Standard stroke length (mm)      Ordering steps	
50...500 mm	25 mm
500...1500 mm	50 mm
X X X X U	002.0...060.0 in.
Standard stroke length (in.)      Ordering steps	
2...20 in.	1.0 in.
20...60 in.	2.0 in.
Non-standard stroke lengths are available; must be encoded in 5 mm/0.1 in. increments.	

d	Connection type
D 3 4	M12 male connector (5 pin)

e	Operating voltage
1	+24 VDC (-15/+20 %)

f	Output
C 3 0 4	CANopen
C 4 0 4	CANopen (bus terminator)

g	Baud rate
1	1000 kBit/s
2	500 kBit/s
3	250 kBit/s
4	125 kBit/s

h	Resolution
4	10 µm
5	20 µm

i	Type
1	Standard

### 3.5 Nameplate

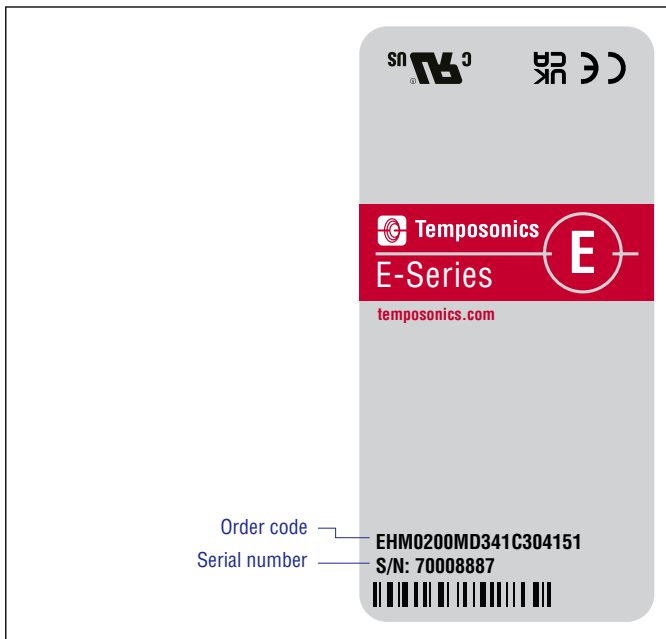

Fig. 1: Example of nameplate of E-Series EH sensor with CANopen output

### 3.6 Approvals

- CE declaration
- UKCA declaration
- UL certified <sup>3</sup>

#### NOTICE

For a detailed overview of the certifications, see:  
[www.temposonics.com](http://www.temposonics.com)

### 3.7 Scope of delivery

#### EH (rod sensor):

- Sensor
- O-ring

#### EP (compact profile sensor):

- Sensor
- 2 mounting clamps up to 1250 mm (50 in.) stroke length +  
1 mounting clamp for each 500 mm (20 in.) additional stroke length

#### EL (ultra low profile sensor):

- Sensor
- 2 mounting clamps up to 1250 mm (50 in.) stroke length +  
1 mounting clamp for each 500 mm (20 in.) additional stroke length

#### EP2 (smooth profile sensor):

- Sensor
- 2 mounting clamps up to 1250 mm (50 in.) stroke length +  
1 mounting clamp for each 500 mm (20 in.) additional stroke length

#### ER (aluminum cylinder with a guided driving rod sensor):

- Sensor

3/ Only sensors with connector outlets are UL certified

## 4. Product description and commissioning

### 4.1 Functionality and system design

#### Product designation

- Position sensor Temposonics® E-Series

#### Sensor model

- Temposonics® E-Series EH (rod sensor)
- Temposonics® E-Series EP (compact profile sensor)
- Temposonics® E-Series EL (ultra low profile sensor)
- Temposonics® E-Series EP2 (smooth profile sensor)
- Temposonics® E-Series ER (aluminum cylinder with a guided driving rod sensor)

#### Stroke length

- Temposonics® E-Series EH: 50...2540 mm (2...100 in.)
- Temposonics® E-Series EP: 50...2540 mm (2...100 in.)
- Temposonics® E-Series EL: 50...2540 mm (2...100 in.)
- Temposonics® E-Series EP2: 50...2540 mm (2...100 in.)
- Temposonics® E-Series ER: 50...1500 mm (2...60 in.)

#### Output signal

- CANopen

#### Application

The Temposonics® position sensors are used for measurement and conversion of the length (position) variable in the fields of automated systems and mechanical engineering.

#### Principle of operation and system construction

The absolute, linear position sensors provided by Temposonics rely on the company's proprietary magnetostrictive technology, which can determine position with a high level of precision and robustness. Each Temposonics® position sensor consists of a ferromagnetic waveguide, a position magnet, a strain pulse converter and supporting electronics. The magnet, connected to the object in motion in the application, generates a magnetic field at its location on the waveguide. A short current pulse is applied to the waveguide. This creates a momentary radial magnetic field and torsional strain on the waveguide. The momentary interaction of the magnetic fields releases a torsional strain pulse that propagates the length of the waveguide. When the ultrasonic wave reaches the beginning of the waveguide it is converted into an electrical signal. Since the speed of the ultrasonic wave in the waveguide is precisely known, the time required to receive the return signal can be converted into a linear position measurement with both high accuracy and repeatability.

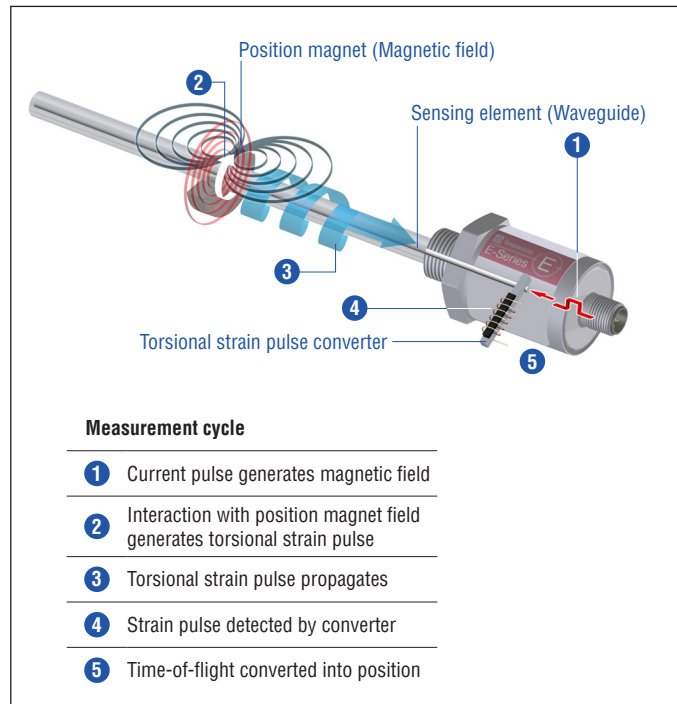

Fig. 2: Time-of-flight based magnetostrictive position sensing principle

#### Modular mechanical and electronic construction

- The sensor profile or rod protects the inner sensor element.
- The sensor electronics housing, a rugged construction, contains the complete electronic interface with active signal conditioning.
- The external position magnet is a permanent magnet. Mounted on the mobile machine part, it travels along the sensor profile or rod and triggers the measurement through the sensor profile/rod wall.
- The sensor can be connected directly to a control system. Its electronics generates a strictly position proportional signal output between start and end position.

## 4.2 Installation and design of Temposonics® EH

### EH with threaded flange M18x1.5-6g or 3/4"-16 UNF-3A, example: Connection type D34 (connector outlet)

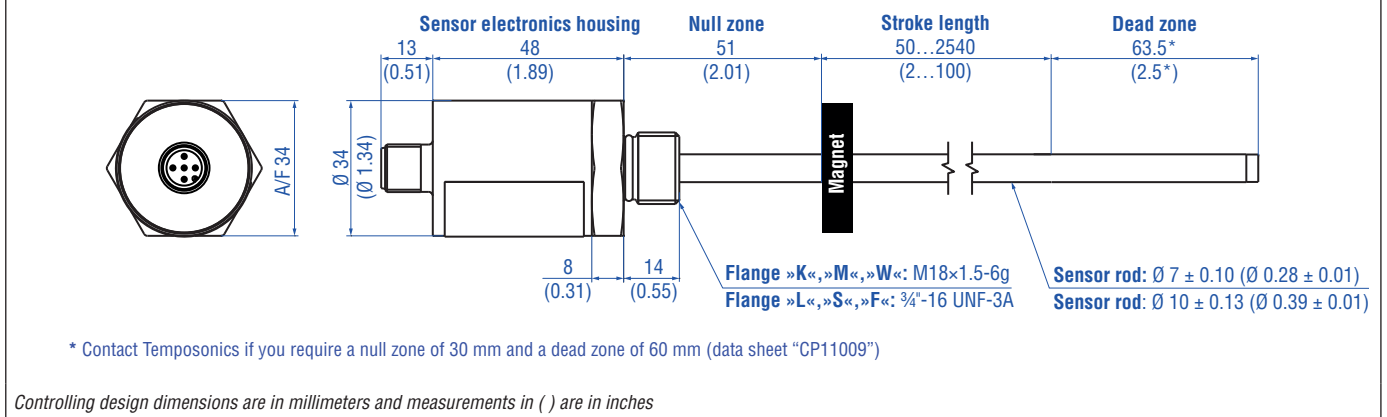

Fig. 3: Temposonics® EH with ring magnet

### Installation of EH with threaded flange

Fix the sensor rod via threaded flange M18x1.5-6g or 3/4"-16 UNF-3A. Note the fastening torque shown in Fig. 4. Lightly oil the thread before tightening.

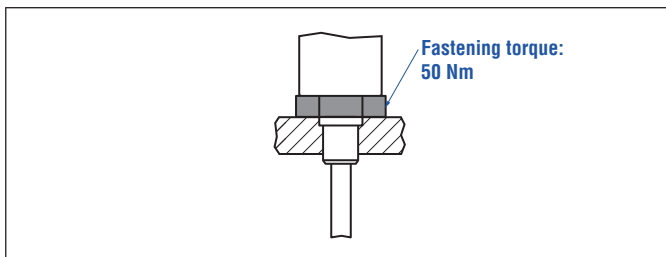

Fig. 4: Mounting example of threaded flange

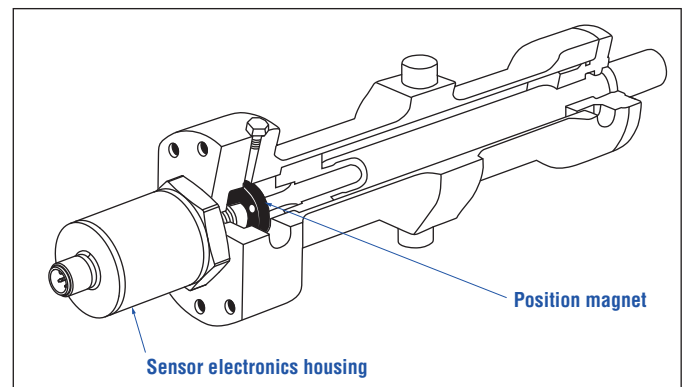

Fig. 5: Sensor in cylinder

### Installation of a rod-style sensor in a fluid cylinder

The rod-style version has been developed for direct stroke measurement in a fluid cylinder. Mount the sensor via threaded flange or a hex nut.

- Mounted on the face of the piston, the position magnet travels over the rod without touching it and indicates the exact position through the rod wall – independent of the hydraulic fluid.
- The pressure resistant sensor rod is installed into a bore in the piston rod.

**Hydraulics sealing**

Seal the flange contact surface via O-ring in the undercut (Fig. 6).

For threaded flange (3/4"-16 UNF-3A) »F« / »L« / »S«:

O-ring 16.4 × 2.2 mm (0.65 × 0.09 in.) (part no. 560315)

For threaded flange (M18×1.5-6g) »K« / »M« / »W«:

O-ring 15.3 × 2.2 mm (0.60 × 0.09 in.) (part no. 401133)

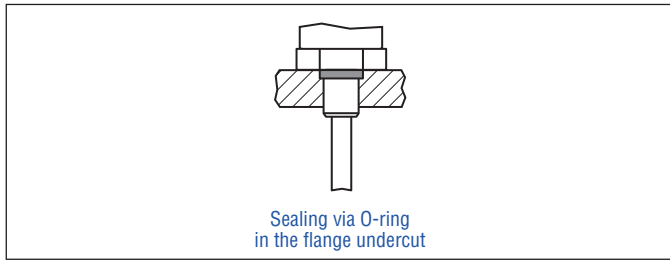

Fig. 6: Possibility of sealing

In the case of threaded flange M18×1.5-6g provide a screw hole based on DIN EN ISO 6149-1 (Fig. 7). See DIN EN ISO 6149-1 for further information.

- Seat the flange contact surface completely on the cylinder mounting surface.
- The cylinder manufacturer determines the pressure-resistant gasket (copper gasket, O-ring, etc.).
- The position magnet should not grind on the sensor rod.
- The piston rod drilling  
(EH-K/-L: Ø 7 mm rod: ≥ Ø 10 mm (≥ Ø 0.40 in.);  
EH-M/-S/-F/-W: Ø 10 mm rod: ≥ Ø 13 mm (≥ Ø 0.52 in.))  
depends on the pressure and piston speed.
- Adhere to the information relating to operating pressure.
- Protect the sensor rod against wear.

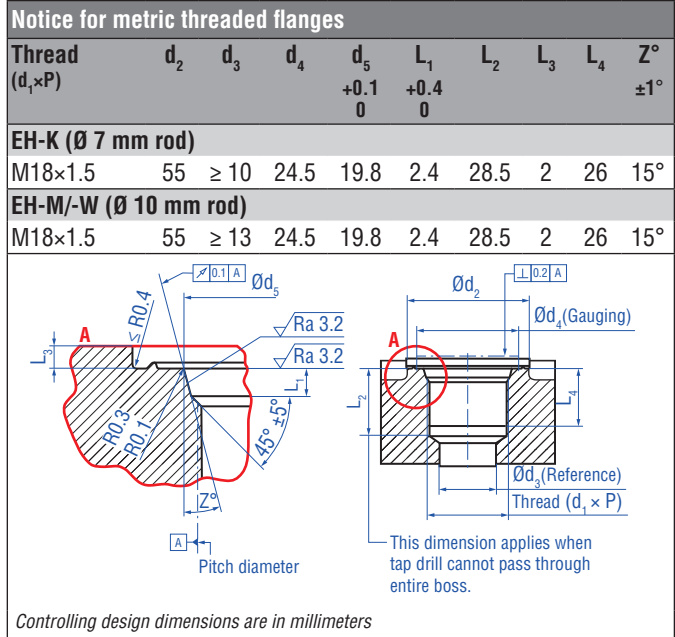

Fig. 7: Notice for metric threaded flange M18×1.5-6g based on DIN ISO 6149-1

### 4.3 Installation and design of Temposonics® EP/EL

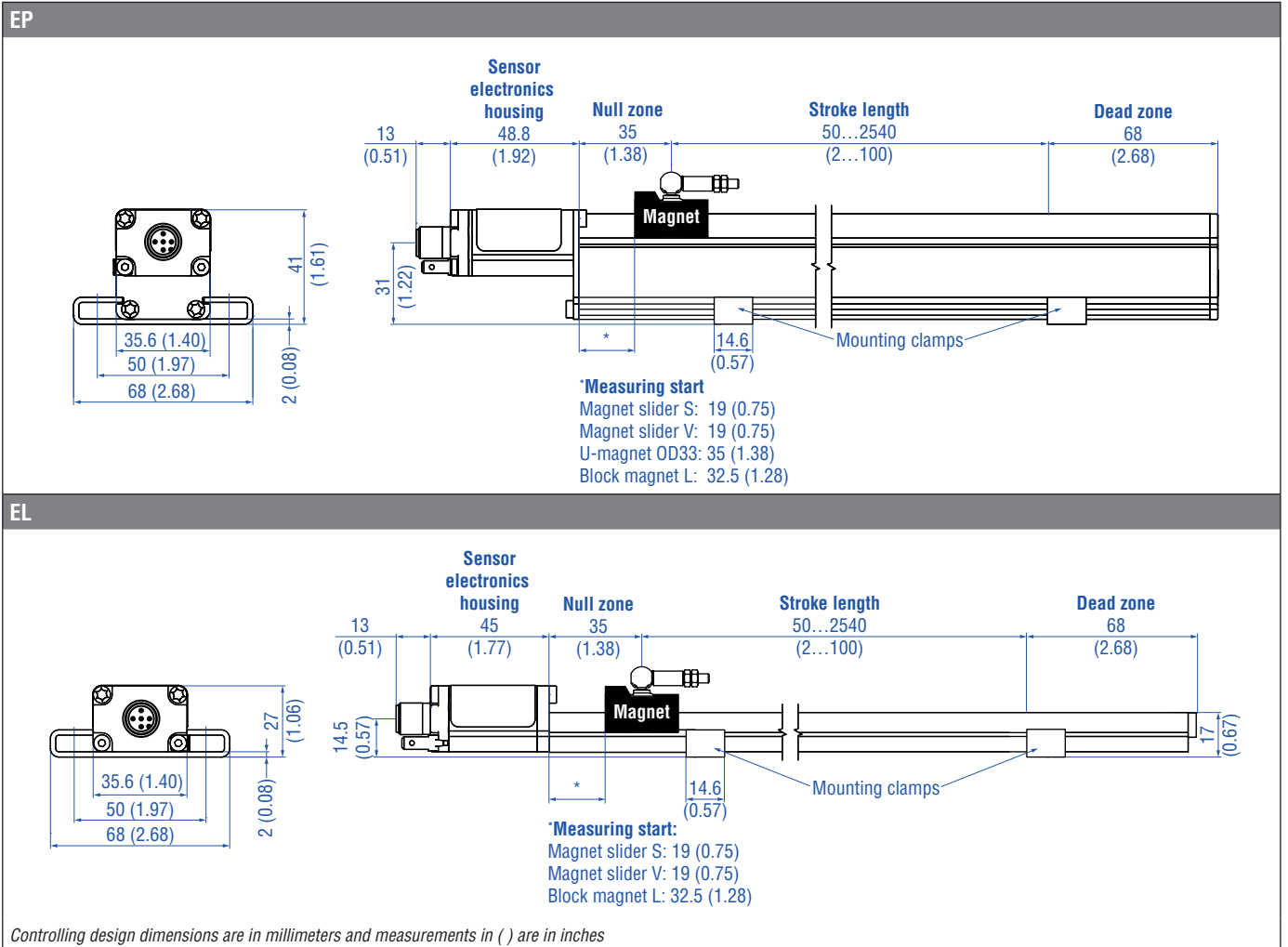

Fig. 8: Temposonics® EP/EL with magnet slider

#### Installation of EP/EL

The position sensor can be installed in any position. Normally, the sensor is firmly installed and the position magnet is fastened to the mobile machine part. Thus it can travel along the sensor profile. The sensor is fitted on a flat machine surface using the mounting clamps (Fig. 9). A length-dependent number of these clamps are delivered with the sensor and must be distributed over the profile at regular distances. For fastening use M5×20 screws to DIN 6912 that should be tightened with a fastening torque of 5 Nm.

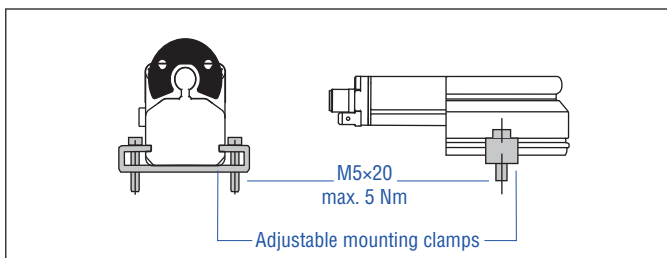

Fig. 9: EP with mounting clamps with cylinder screw M5×20 (part no. 403 508)

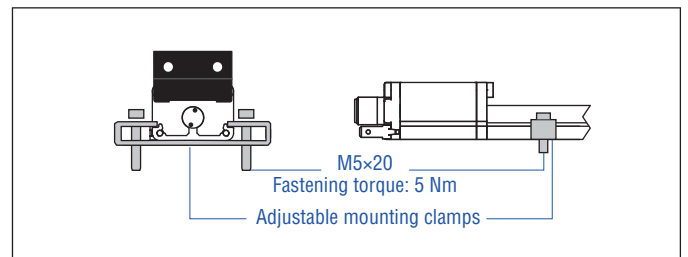

Fig. 10: EL with mounting clamps with cylinder screw M5×20 (part no. 403 508)

#### NOTICE

Take care to mount the sensor in an axially parallel position to avoid damage to magnet and sensor rod.

#### 4.4 Installation and design of Temposonics® EP2

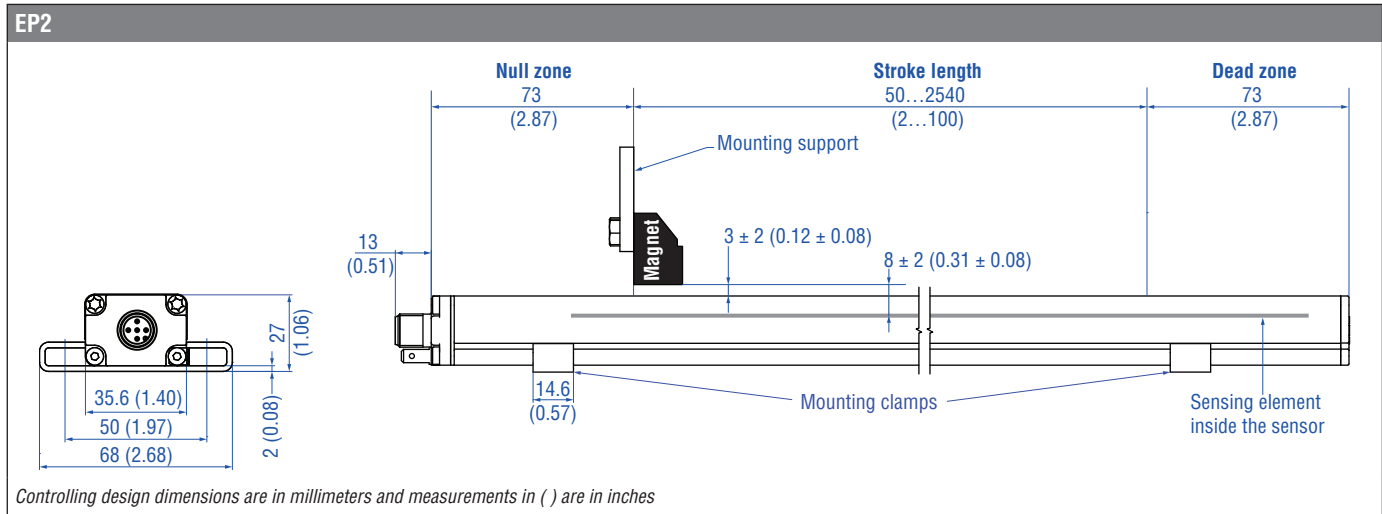

Fig. 11: Temposonics® EP2 with block magnet

#### Installation of EP2

The position sensor can be installed in any position. Normally, the sensor is firmly installed and the position magnet is fastened to the mobile machine part. Thus it can travel along the measuring rod without touching it. The sensor is fitted on a flat machine surface using the mounting clamps (Fig. 12). A length-dependent number of these clamps are delivered with the sensor and must be distributed over the profile at regular distances. For fastening use M5×20 screws to DIN 6912 that should be tightened with a fastening torque of 5 Nm.

#### NOTICE

- Take care to mount the sensor in an axially parallel position to avoid impairment of the position measurement.
- To ensure a reliable position measurement align all block magnets for a multi-position measurement so that the air gap of all magnets has the same height.

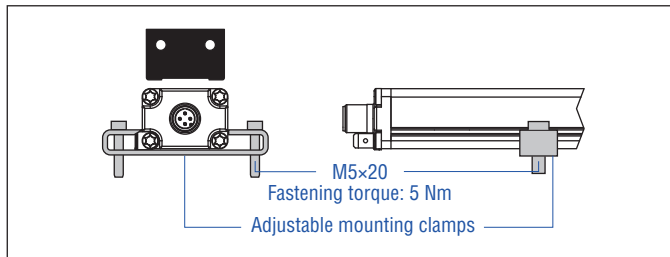

Fig. 12: Mounting clamps with cylinder screw M5×20 (part no. 403 508)

#### 4.5 Installation and design of Temposonics® ER

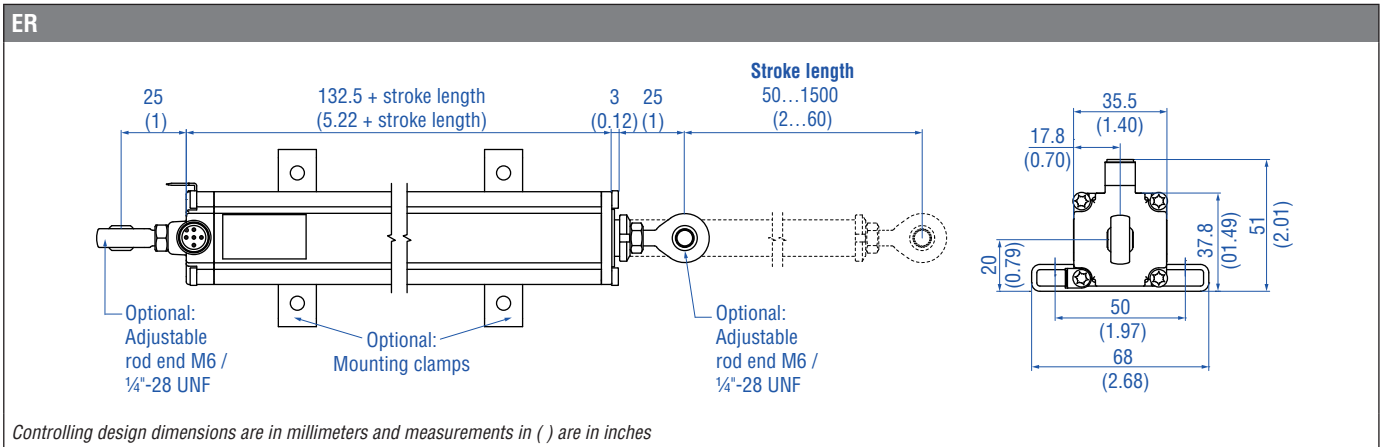

Fig. 13: Temposonics® ER

#### There are two ways to install the sensor ER:

##### 1. Via the mounting clamps

The position sensor can be installed in any position. The sensor is fitted on a flat machine surface using the mounting clamps (Fig. 14), while the guided driving rod is attached to the moving machine part. The mounting clamps are supplied in length-dependent quantities and must be evenly distributed on the profile. For fastening use M5×20 screws to DIN 6912 that should be tightened with a fastening torque of 5 Nm. The guided driving rod is fitted with an internal thread M6 or 1/4" for connection to the moving machine part. Alternatively, the connection can also be made using the M6 or 1/4" rod end available as an accessory.

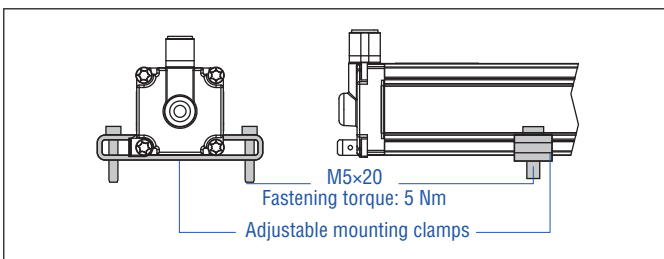

Fig. 14: Mounting clamps with cylinder screw M5×20 (part no. 403 508)

#### NOTICE

Take care to mount the sensor in an axially parallel position to avoid damage to the sensor.

##### 2. Suspension via the adjustable rod ends

The position sensor can be installed in any position. Tighten the M6 or 1/4" rod ends, which are available as accessories, into the M6 or 1/4" internal threads on both sides of the sensor. Suspend the sensor in the machine via the rod ends so that the guided driving rod is connected to the moving part of the machine.

#### NOTICE

Do not extend the driving rod more than 75 % of the stroke length to avoid the driving rod from getting caught.

#### NOTICE

Do not raise up the ER sensor, if the driving rod is extended.

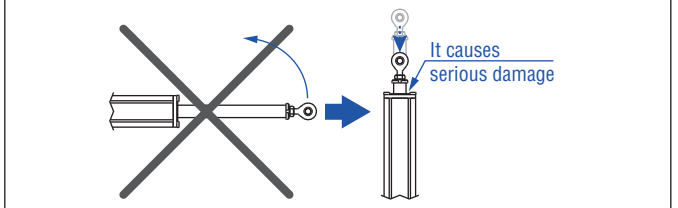

## 4.6 Magnet installation

### Typical use of magnets



Magnet	Typical sensors	Benefits
 <p><b>Ring magnets</b></p>	<b>Rod model</b> (EH)	<ul style="list-style-type: none"> <li>Rotationally symmetrical magnetic field</li> </ul>
 <p><b>U-magnets</b></p>	<b>Profile &amp; rod models</b> (EH, EP)	<ul style="list-style-type: none"> <li>Height tolerances can be compensated, because the magnet can be lifted off</li> </ul>
 <p><b>Block magnets</b></p>	<b>Profile &amp; rod models</b> (EH, EP, EL, EP2)	<ul style="list-style-type: none"> <li>Height tolerances can be compensated, because the magnet can be lifted off</li> </ul>
 <p><b>Magnet sliders</b></p>	<b>Profile models</b> (EP, EL)	<ul style="list-style-type: none"> <li>The magnet is guided by the profile</li> <li>The distance between the magnet and the waveguide is strictly defined</li> <li>Easy coupling via the ball joint</li> </ul>

Fig. 15: Typical use of magnets

### Mounting the ring magnets, U-magnets & block magnets

Install the magnet using non-magnetic material for mounting device, screws, spacers etc.. The magnet must not grind on the sensor rod/profile. Alignment errors are compensated via the air gap.

- Permissible surface pressure: Max. 40 N/mm<sup>2</sup> (only for ring magnets and U-magnets)
- Fastening torque for M4 screws: 1 Nm; use washers, if necessary
- Minimum distance between position magnet and any magnetic material has to be 15 mm (0.6 in.) (Fig. 18).
- If no other option exists and magnetic material is used, observe the specified dimensions (Fig. 18).

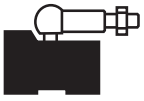
### NOTICE

- Mount ring magnets and U-magnets concentrically.
- Mount block magnets centrally over the sensor rod or the sensor profile. The maximum permissible air gap must not be exceeded (Fig. 16, Fig. 17).
- Take care to mount the primary sensor axis in parallel to the magnet path in order to avoid damage to the carriage, magnet and sensor rod/profile.

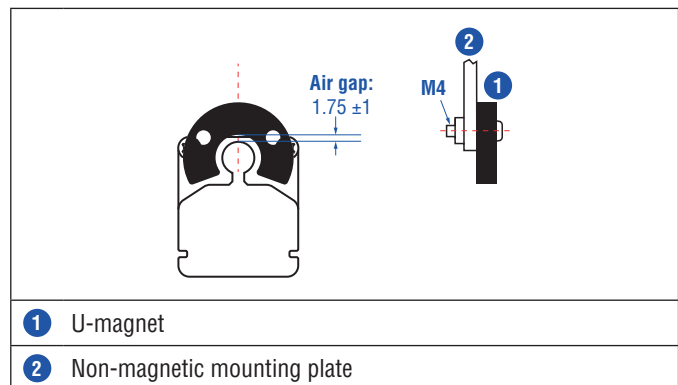

Fig. 16: Mounting of U-magnet (part no. 251 416-2), example of EP sensor

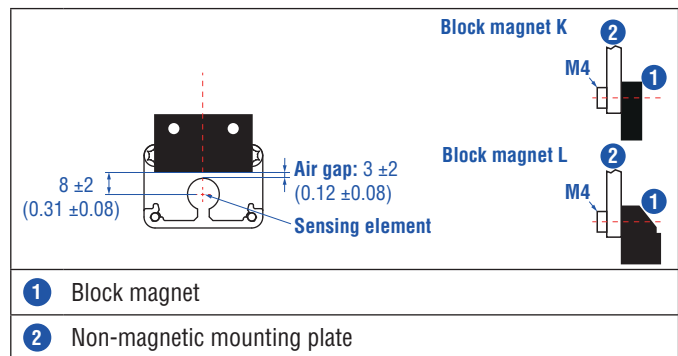

Fig. 17: Mounting of block magnet K (part no. 251 298-2) and block magnet L (part no. 403 448), example of EL sensor

### Magnet mounting with magnetic material

When using magnetic material the dimensions of Fig. 18 must be observed.

- If the position magnet aligns with the drilled piston rod
- If the position magnet is set further into the drilled piston rod, install another non-magnetic spacer (e.g. part no. 400 633) above the magnet.

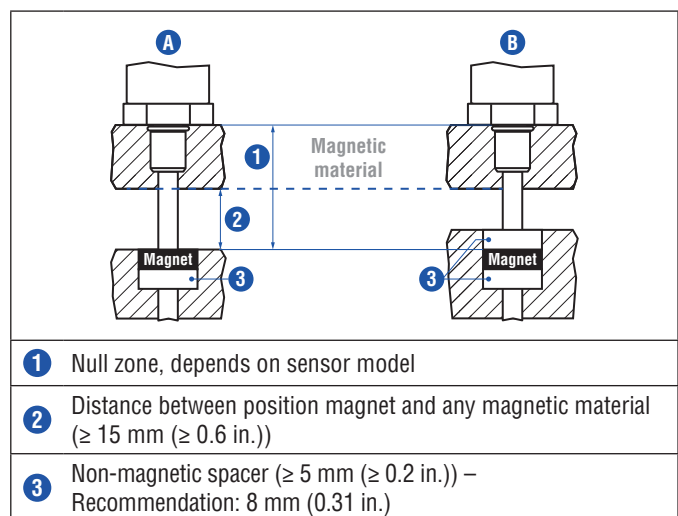

Fig. 18: Installation with magnetic material

**Rod sensors with stroke lengths  $\geq 1$  meter (3.3 ft.)**

Support horizontally installed rod sensors with a stroke length from 1 meter (3.3 ft.) mechanically at the rod end. Without the use of a support, rod and position magnet may be damaged. A false measurement result is also possible. Longer rods require evenly distributed mechanical support over the entire length (e.g. part no. 561 481). Use an U-magnet (Fig. 19) for measurement.

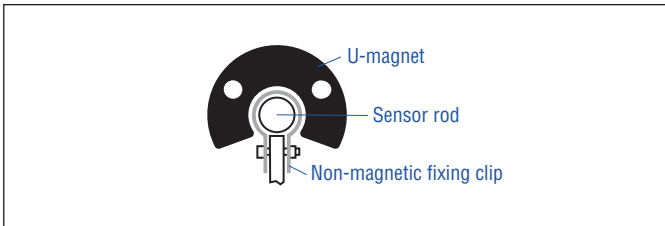

Fig. 19: Example of sensor support (part no. 561 481)

**Start and end positions of the position magnets**

Consider the start and end positions of the position magnets during the installation. To ensure that the entire stroke length is electrically usable, the position magnet must be mechanically mounted as follows.

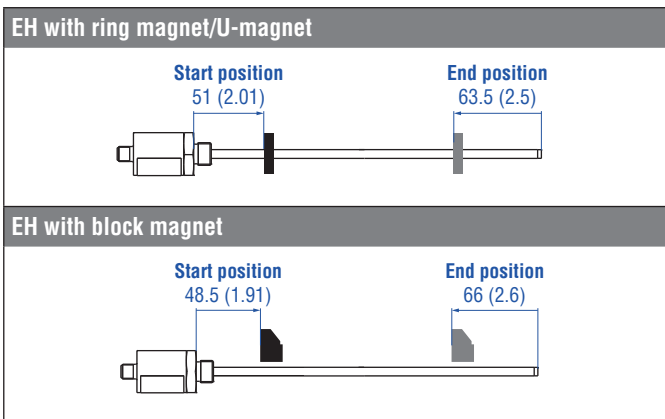

Fig. 20: Start- and end positions of magnets for EH

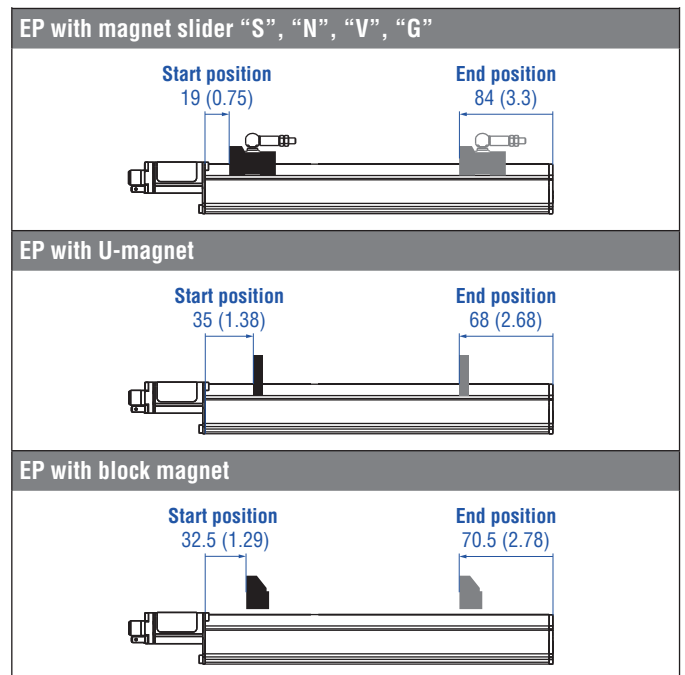

Fig. 21: Start- and end positions of magnets for EP

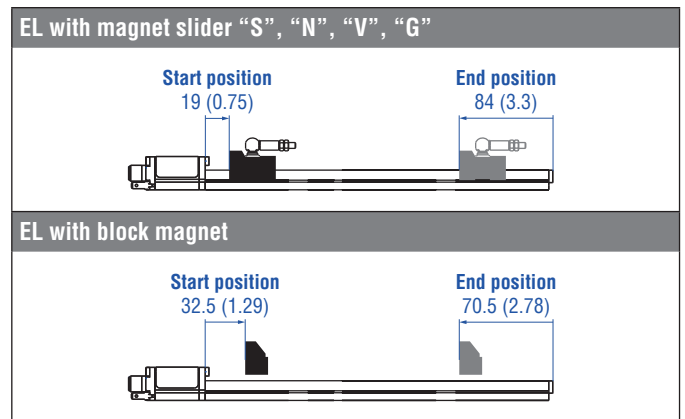

Fig. 22: Start- and end positions of magnets for EL

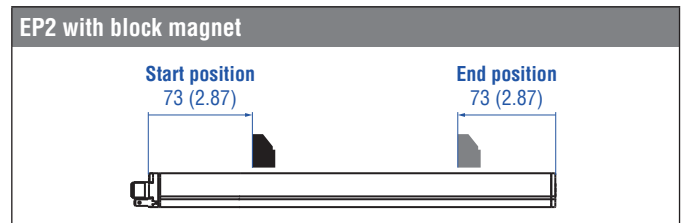

Fig. 23: Start- and end positions of magnets for EP2

**Multi-position measurement**

The minimum distance between the magnets is 75 mm (3 in.).

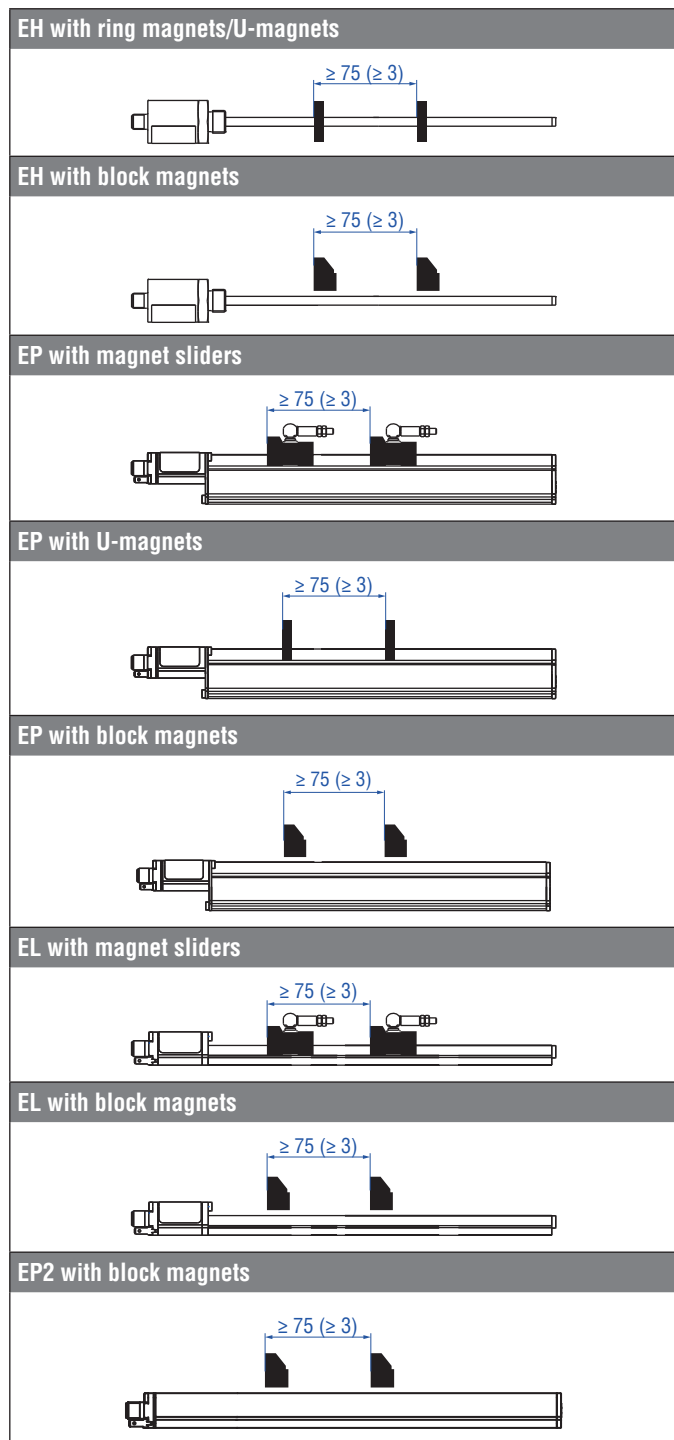

Fig. 24: Minimum distance for multi-position measurement

**NOTICE**

Use magnets of the same type for multi-position measurement. Do not go below a minimal distance of 75 mm (3 in.) between the magnets for multi-position measurement. Contact Temposonics if you need a magnet distance, which is smaller than 75 mm (3 in.).

#### 4.7 Electrical connections

Placement of installation and cabling have decisive influence on the sensor's electromagnetic compatibility (EMC). Hence correct installation of this active electronic system and the EMC of the entire system must be ensured by using suitable metal connectors, shielded<sup>4</sup> cables and grounding. Overvoltages or faulty connections can damage its electronics despite protection against wrong polarity.

#### NOTICE

1. Do not mount the sensors in the area of strong magnetic or electric noise fields.
2. Never connect/disconnect the sensor when voltage is applied.

#### Instructions for connection

- Use low-resistant twisted pair and shielded cables. Connect the shield to ground externally via the control system equipment.
- Keep control and sign leads separate from power cables and sufficiently far away from motor cables, frequency inverters, valve lines, relays, etc..
- Use only connectors with metal housing and connect the shielding to the connector housing.
- Keep the connection surface at both shielding ends as large as possible. Connect the cable clamps to function as a ground.
- Keep all non-shielded leads as short as possible.
- Keep the earth connection as short as possible with a large cross section. Avoid ground loops.
- With potential differences between machine and electronics earth connections, no compensating currents are allowed to flow across the cable shielding.

#### Recommendation:

Install potential compensating leads with large cross section, or use cables with separate double shielding, and connect only one end of the shield.

- Use only stabilized power supplies in compliance with the specified electrical ratings.

#### Grounding of profile and rod sensors

Connect the sensor electronics housing to machine ground. Ground sensor models EP, EL, EP2 and ER via ground lug as shown in Fig. 25. The sensor model EH is grounded via thread.

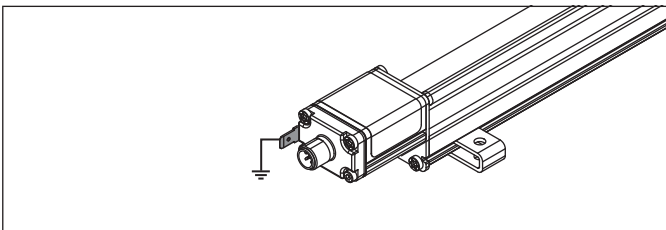

Fig. 25: Grounding via ground lug on the example of an EP sensor

D34		
Signal + power supply		
M12 male connector (A-coded)	Pin	Function
<p>View on sensor</p>	1	Shield
	2	+24 VDC (-15/+20 %)
	3	DC Ground (0 V)
	4	CAN_H
	5	CAN_L

Fig. 26: Connector wiring D34

EH with cable outlet (EHX/ETX)		
Signal + power supply		
Cable	Color	Function
	GY	CAN_L
	PK	CAN_H
	YE	Not connected
	GN	Not connected
	BN	+24 VDC (-15/+20 %)
	WH	DC Ground (0 V)

Fig. 27: Connector wiring for EH with cable outlet

<sup>4/</sup> The use of shielded cables is a recommendation of Temposonics to afford a better protection against signal disturbances

4.8 Frequently ordered accessories for Tempsonics® EH – Additional options available in our [Accessories Catalog](#) 551 444

Position magnets

<p><b>U-magnet OD33</b> Part no. 251 416-2</p>	<p><b>Ring magnet OD33</b> Part no. 201 542-2</p>	<p><b>Ring magnet OD25.4</b> Part no. 400 533</p>	<p><b>Ring magnet OD17.4</b> Part no. 401 032</p>
<p>Material: PA ferrite GF20 Weight: Approx. 11 g Surface pressure: Max. 40 N/mm<sup>2</sup> Fastening torque for M4 screws: 1 Nm Operating temperature: -40...+105 °C (-40...+221 °F)</p>	<p>Material: PA ferrite GF20 Weight: Approx. 14 g Surface pressure: Max. 40 N/mm<sup>2</sup> Fastening torque for M4 screws: 1 Nm Operating temperature: -40...+105 °C (-40...+221 °F)</p>	<p>Material: PA ferrite Weight: Approx. 10 g Surface pressure: Max. 40 N/mm<sup>2</sup> Operating temperature: -40...+105 °C (-40...+221 °F)</p>	<p>Material: PA neobond Weight: Approx. 5 g Surface pressure: Max. 20 N/mm<sup>2</sup> Operating temperature: -40...+105 °C (-40...+221 °F)</p>

Position magnets

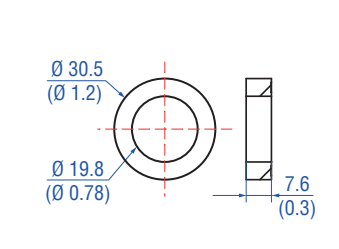

**Ring magnet**  
Part no. 402 316

Material: PA ferrite coated  
Weight: Approx. 13 g  
Surface pressure: Max. 20 N/mm<sup>2</sup>  
Operating temperature:  
-40...+100 °C (-40...+212 °F)

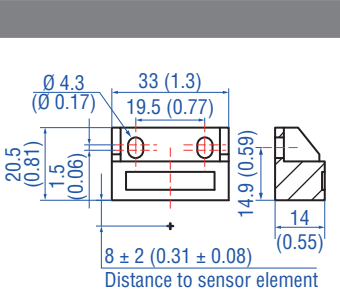

**Block magnet L**  
Part no. 403 448

Material: Plastic carrier with hard ferrite magnet  
Weight: Approx. 20 g  
Fastening torque for M4 screws: 1 Nm  
Operating temperature:  
-40...+75 °C (-40...+167 °F)

This magnet may influence the sensor performance specifications for some applications.

Magnet spacer

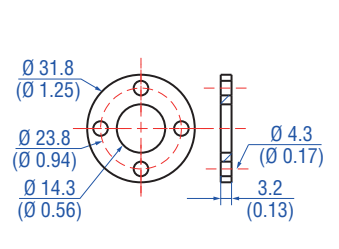

**Magnet spacer**  
Part no. 400 633

Material: Aluminum  
Weight: Approx. 5 g  
Surface pressure: Max. 20 N/mm<sup>2</sup>  
Fastening torque for M4 screws: 1 Nm

O-ring

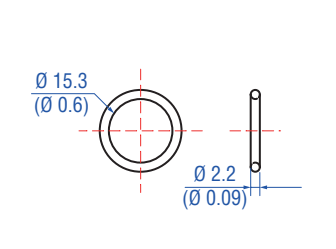

**O-ring for threaded flange**  
M18×1.5-6g  
Part no. 401 133

Material: Fluoroelastomer  
Durometer: 75 ±5 Shore A  
Operating temperature:  
-40...+204 °C (-40...+400 °F)

O-ring

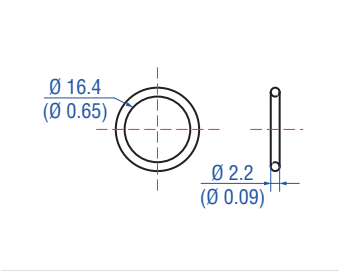

**O-ring for threaded flange**  
¼"-16 UNF-3A  
Part no. 560 315

Material: Fluoroelastomer  
Durometer: 75 ±5 Shore A  
Operating temperature:  
-40...+204 °C (-40...+400 °F)

Mounting accessories

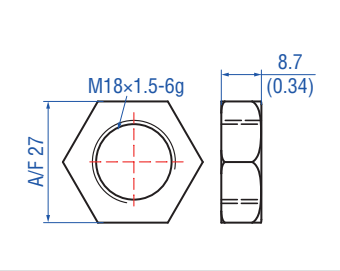

**Hex jam nut M18×1.5-6g**  
Part no. 500 018

Material: Steel, zinc plated

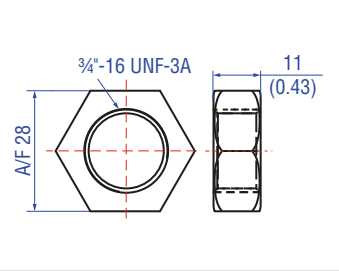

**Hex jam nut ¼"-16 UNF-3A**  
Part no. 500 015

Material: Steel, zinc plated

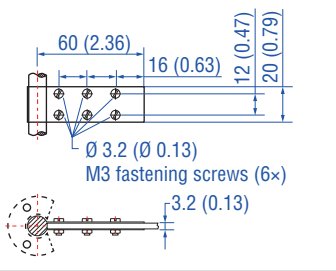

**Fixing clip**  
Part no. 561 481

Application: Used to secure sensor rods (Ø 10 mm (Ø 0.39 in.)) when using an U-magnet or block magnet  
Material: Brass, non-magnetic

4.9 Frequently ordered accessories for Temposonics® EP/EL – Additional options available in our [Accessories Catalog](#) 551 444

Position magnets

<p><b>Magnet slider S, joint at top</b> Part no. 252 182</p>	<p><b>Magnet slider V, joint at front</b> Part no. 252 184</p>	<p><b>U-magnet OD33</b> Part no. 251 416-2</p>	<p><b>Block magnet L</b> Part no. 403 448</p>
<p>Material: GRP, magnet hard ferrite Weight: Approx. 35 g Operating temperature: -40...+85 °C (-40...+185 °F)</p>	<p>Material: GRP, magnet hard ferrite Weight: Approx. 35 g Operating temperature: -40...+85 °C (-40...+185 °F)</p>	<p>Material: PA ferrite GF20 Weight: Approx. 11 g Surface pressure: Max. 40 N/mm<sup>2</sup> Fastening torque for M4 screws: 1 Nm Operating temperature: -40...+105 °C (-40...+221 °F)</p>	<p>Material: Plastic carrier with hard ferrite magnet Weight: Approx. 20 g Fastening torque for M4 screws: 1 Nm Operating temperature: -40...+75 °C (-40...+167 °F)</p> <p>This magnet may influence the sensor performance specifications for some applications.</p>

Mounting accessory

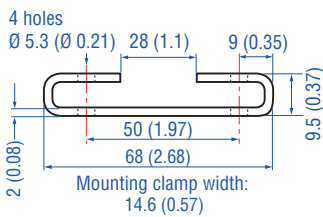

**Mounting clamp**  
Part no. 403 508

Material: Stainless steel 1.4301/1.4305  
(AISI 304/303)

**4.10 Frequently ordered accessories for Temposonics® EP2** – Additional options available in our [Accessories Catalog](#)  [551 444](#)

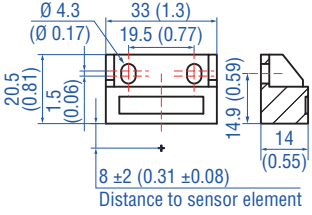
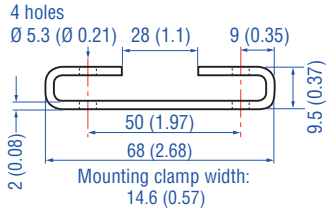
Position magnet	Mounting accessory
	
<p><b>Block magnet L</b> <b>Part no. 403 448</b></p>	<p><b>Mounting clamp</b> <b>Part no. 403 508</b></p>
<p>Material: Plastic carrier with hard ferrite magnet Weight: Approx. 20 g Fastening torque for M4 screws: 1 Nm Operating temperature: -40...+75 °C (-40...+167 °F)</p> <p>This magnet may influence the sensor performance specifications for some applications.</p>	<p>Material: Stainless steel 1.4301/1.4305 (AISI 304/303)</p>

4.11 Frequently ordered accessories for Temposonics® ER – Additional options available in our [Accessories Catalog](#) 551 444

Mounting accessories

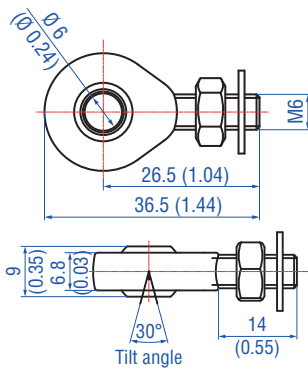

**Rod end with M6 thread**  
**Part no. 254 210**

Material: Galvanized steel

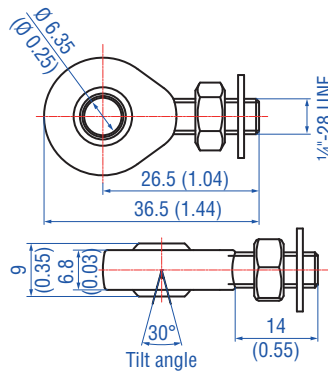

**Rod end with 1/4\"/>**

Material: Galvanized steel

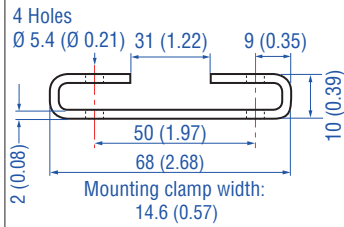

**Mounting clamp**  
**Part no. 403 508**

Material: Stainless steel 1.4301/1.4305  
(AISI 304/303)

4.12 Frequently ordered accessories for CANopen output – Additional options available in our [Accessories Catalog](#) 551 444

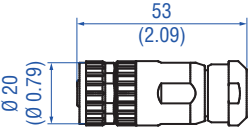
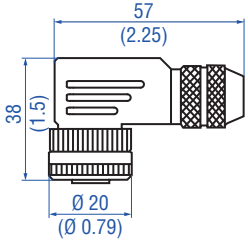
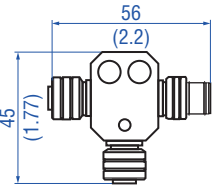
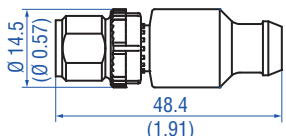
Cable connectors*		Connection accessories	
			
<b>M12 A-coded female connector (4 pin/5 pin), straight</b> Part no. 370 677	<b>M12 A-coded female connector (5 pin), angled</b> Part no. 370 678	<b>M12 A-coded T connector (5 pin)</b> Part no. 370 691	<b>Passive M12 A-coded male bus terminator (5 pin)</b> Part no. 370 700
Material: GD-Zn, Ni Termination: Screw Contact insert: CuZn Cable Ø: 4...8 mm (0.16...0.31 in.) Wire: max. 1.5 mm <sup>2</sup> (16 AWG) Operating temperature: -30...+85 °C (-22...+185 °F) Ingress protection: IP67 (correctly fitted) Fastening torque: 0.6 Nm	Material: GD-Zn, Ni Termination: Screw Contact insert: CuZn Cable Ø: 5...8 mm (0.2...0.31 in.) Wire: max 0.75 mm <sup>2</sup> (18 AWG) Operating temperature: -25...+85 °C (-13...+185 °F) Ingress protection: IP67 (correctly fitted) Fastening torque: 0.4 Nm	Selfcuring coupling nut 2 × female connector 1 × male connector Feature: Shielded Ingress protection: IP67 (correctly fitted)	Material: PUR Termination: Screw Contact insert: Au Operating temperature: -25...+85 °C (-13...+121 °F) Ingress protection: IP68 (correctly fitted)
Cables			

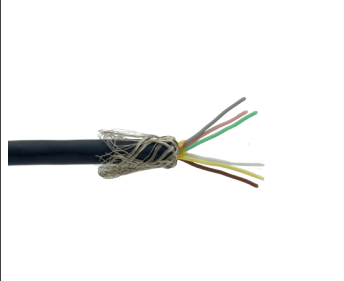
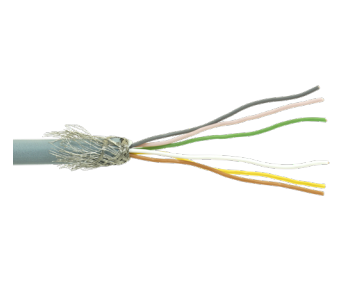

**PUR cable**  
Part no. 530 166

Material: PUR jacket; grey  
Features: Flexible, halogen free, mostly oil resistant  
Cable Ø: 6.2 mm (0.24 in.)  
Cross section: 3 × 2 × 0.14 mm<sup>2</sup>  
Bending radius: 7.5 × D  
Operating temperature: -40...+80 °C (-40...+176 °F)

**FEP cable**  
Part no. 530 157

Material: FEP jacket; black  
Features: Twisted pair, shielded  
Cable Ø: 6.7 mm (0.26 in.)  
Cross section: 3 × 2 × 0.14 mm<sup>2</sup>  
Operating temperature: -40...+180 °C (-40...+356 °F)

\*/ Follow the manufacturer's mounting instructions  
Color of connectors and cable jacket may change. Color codes for the individual wires and technical properties remain unchanged.  
Controlling design dimensions are in millimeters and measurements in ( ) are in inches

## 5. Commissioning

### CANopen bus interface

CANopen is a CAN-based (Controller Area Network) high-layer communication protocol for distributed industrial automation technology. CAN is a vendor independent open fieldbus system, based on standard ISO 11898. CAN specifies the functional and technical parameters with which the intelligent digital automation devices can be networked via a master-slave serial link by using a communication profile. Protocol architecture of functional and applications data is oriented to the OSI reference model (ISO 7498). Bus technology is administrated and developed by the user organisation CiA (CAN in Automation).

### 5.1 Encoder functionality system description

The position sensor E-Series CANopen is suitable for a CANopen protocol network. The sensor can be used as a CAN bus slave in networks with the CANopen data protocol (CiA Standard DS 301 V4.02), the encoder profile DS 406 V3.2 and the LSS Service DS 305 V2.1.1. The sensor is performing Class C2 functionality.

### Network Management (NMT) – Slave

The NMT state machine defines the communication behavior of the CANopen device.

### Layer Setting Services (LSS) DS 305

Layer Setting Services (LSS) are used in order to configure the sensor in terms of node-ID and/or the baud rate. The sensor can be switched to LSS configuration mode either globally or selectively.

### Service Data Object (SDO)

SDO messages are used for reading and writing access to all entries of the object dictionary. SDOs are used for device configuration in the first place.

### Identity objects

Identity including vendor-ID, product code, revision number and serial number.

### Variable Process Data Object (PDO) mapping

The real-time data transfer of position, velocity and limit switch states is performed by PDO messages. Data is transmitted within four TPDO's (transmit PDO) and each with a maximum 8 byte wide data block. Variable PDO mapping can be configured via SDO messages.

### Special Function Object (SFO) sync object

The sync object is broadcasted periodically by the synchronisation device to all application devices. Synchronous PDOs will be transmitted to the controller after receiving the sync message.

### Emergency object

Emergency messages are triggered by the occurrence of a device internal fatal error situation and are transmitted from the application device concerned to the other devices with highest priority. This makes them suitable for interrupting type error alerts.

### Node guarding object

The node guarding object is used to monitor the whole network state. The node guarding object is sent cyclically to detect the sensor that the controller works well. On a missing node guarding object (i.e. controller stopped) the sensor automatically can stop PDO data transmission to reduce the busload.

### Heartbeat function

Instead of the node guarding the heartbeat-function can be used. The Producer-Heartbeat-Time defines the time frame in which a new heartbeat message is sent.

### Event timer

The event timer defines the asynchronous transmission period for PDOs.

### Encoder profile DS 406

Up to four work areas with upper and lower limits and corresponding status register are possible. Up to four cam switches with upper or lower threshold level and status register are available.

### CANbus connection

The CANopen encoders are equipped with a bus trunk line in various lengths and can be terminated in the device. The devices do not have an integrated T-coupler nor they are looped internally. If possible, drop lines should be avoided, as in principle, they lead to signal reflections. As a rule the reflections caused by the drop lines are not critical, if they have completely decayed before the point in time when the scanning occurs.

## 5.2 Encoder installations configuration of node parameters

### LSS address

Each sensor (node) in the CAN network is defined unique by the LSS address. This address consists of:

Vendor-ID: 0x40  
Product Code: 0x0000000E (E-Series)  
Revision No.: 0x03090001  
Serial No.: e.g. 70008887

CANbus specific parameters like baud rate and node address (node-ID) can be configured and recorded by LSS service routines.

### Configure baud rate

The maximum baud rate depends on the cable length of the total CAN network. The baud rate of the sensor is set according to the order code, as printed on the sensor label. If necessary, the baud rate can be changed via LSS service.

#### NOTICE

Program the baud rates according to the LSS protocol.  
Note the parameters given in Table 1.

Cable length	Baud rate
< 25 m (82 ft.)	1000 kBit/s
< 100 m (328 ft.)	500 kBit/s
< 250 m (820 ft.)	250 kBit/s
< 500 m (1640 ft.)	125 kBit/s

Table 1: Baud rate according to cable length (see CiA DS 301)

### Configure node-ID

Each node gets a node identifier (node-ID) for identification in a CANopen network. Each node-ID can be assigned only once in a CAN network. Valid node-IDs range is from 1...127, with 127 being the default setting on delivery.

### Bus termination

For internal bus termination select CANopen (bus terminator) (C404) in section **f** "Output" of the order code (section **e** for sensor model EP2).

### EDS file

The EDS file (Electronic Data Sheet) is the standardized format for the description of devices. It contains information about:

- File properties (name, version, release date,...)
- General device information (manufacturer name and code)
- Device name and type, version, LSS address
- Supported baud rates and boot-up options
- Description of supported objects and attributes

#### NOTICE

The EDS file for E-Series CANopen is available at  
[www.temposonics.com](http://www.temposonics.com)

## 5.3 Configuration of process parameters

The sensor starts up using the parameters stored in its internal NVRAM (Non-Volatile Random Access Memory); the user can change and/or permanently store settings using SDO uploads as desired. Note that in case the node-ID is changed using LSS, the identifiers for PDOs etc. will be changed accordingly.

The sensor implements the encoder communication profile "Device Profile for Encoder – DS 406 V3.2". In the object dictionary the programming of the operating parameters is described.

## 5.4 CANopen Network Management (NMT)

The following description is part of the CANopen communication profile DS 301.

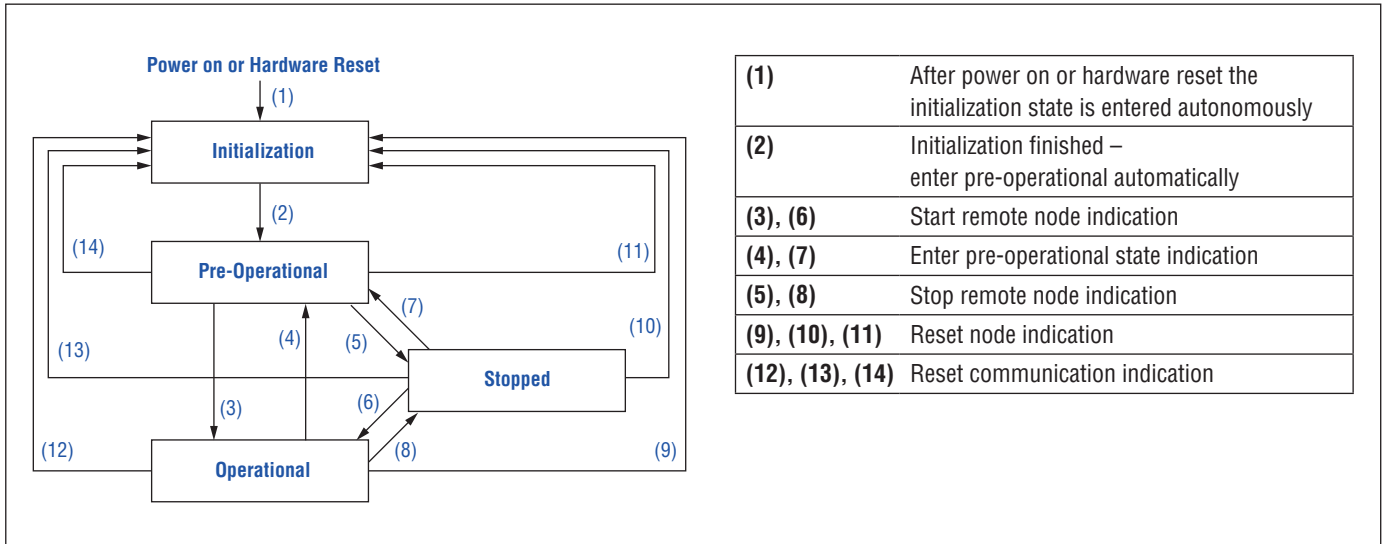

Fig. 28: CANopen state machine

COB-ID	Request/Respond	DLC	Data		Description
			D0	D1	
0x000	Rx	2	<b>Command</b>	<b>Address</b>	
			0x01		<b>Start remote node (3), (6):</b> Through this service the NMT master sets the state of the selected NMT slave(s) to “operational”.
			0x02		<b>Stop remote node (5), (8):</b> Through this service the NMT master sets the state of the selected NMT slave(s) to “stopped”.
			0x80		<b>Enter pre-operational state (4), (7):</b> Through this service the NMT master sets the state of the selected NMT slave(s) to “pre-operational”.
			0x81		<b>Reset node (9), (10), (11):</b> Through this service the NMT master sets the state of the selected NMT slave(s) from any state to the “reset application” sub-state.
			0x82		<b>Reset communication (12), (13), (14):</b> Through this service the NMT master sets the state of the selected NMT slave(s) from any state to the “reset communication” sub-state. After completion of the service, the state of the selected remote nodes will reset communication.
			0x00		set 0x00 for all devices (global mode)
			Node-ID		set node-ID (0x01...0x7F) for a specific device

Table 2: Description of NMT commands

### Network initialization

When powering the sensor after a Network Management (NMT) reset command or after an internal reset, the sensor automatically enters the NMT initialization state. In this state the sensor loads all parameters from the non-volatile memory into the RAM. The sensor performs several test functions and configuration tasks. In this state there is no communication with the sensor. After finishing the NMT initialization state the sensor automatically enters the NMT pre-operational state. During this state transition the CANopen sensor sends its boot-up message (Table 3).

COB ID	Rx/Tx	DLC	DATA
			DO
0x700 + Node-ID	Tx	1	0x00

Table 3: Boot-up message

### Network Pre-Operational state

In the pre-operational state communication via SDOs (chapter 5.6) is possible, while (PDO) communication is not allowed. Configuration of PDOs and device parameters may be performed. Also the emergency objects and error control service like the CANopen sensors “heartbeat message” occur in this state. The node will be switched into the operational state directly by sending a NMT “start remote node” (3) (Fig. 28).

### Network Operational State

In the operational state all communication objects – including PDO handling – are active. Object dictionary access via SDO is possible.

### Network Stopped State

By switching a device into the stopped state it is forced to stop the communication, except node guarding and heartbeat, if active.

## 5.5 Configuration

The complete configuration of the E-Series CANopen sensor is done through the CANbus interface.

### 5.5.1. Layer Setting Service (LSS)

The node-ID and the baud rate can be programmed by using the LSS protocol DS 305 published by the CiA.

The following table describes the settings that can be changed via the LSS protocol.

COB ID	Request/ Respond	DLC	DATA								Description			
			D0	D1	D2	D3	D4	D5	D6	D7				
0x7E5	Rx	8	<b>Entry</b>	<b>Index</b>	0x00	0x00	0x00	0x00	0x00	0x00	0x00			
			0x04	0x01								Configuration mode ( <i>without confirmation</i> )		
				0x00									Waiting state/Normal mode ( <i>without confirmation</i> )	
			0x11	0x01...0x7F									Set node-ID (1...127)	
			0x13	0x00	0x00									Set baud rate 1000 kbit/s
				0x00	0x01									Set baud rate 800 kbit/s
				0x00	0x02									Set baud rate 500 kbit/s
				0x00	0x03									Set baud rate 250 kbit/s
				0x00	0x04									Set baud rate 125 kbit/s
				0x00	0x06									Set baud rate 50 kbit/s
				0x00	0x07									Set baud rate 20 kbit/s
			0x15	Switch delay (in ms)										Active bit timing parameter switch delay according to DS305
			0x17											Store configuration in NVRAM
			0x40											Vendor-ID
			0x41											Product code
			0x42											Revision number
			0x43											Serial number
			0x5A											Inquire identity vendor-ID
			0x5B											Inquire identity product code
			0x5C											Inquire identity revision number
0x5D											Inquire identity serial number			
0x5E											Inquire node-ID			
0x7E4	Tx	8	<b>Entry</b>	<b>Status</b>	0x00	0x00	0x00	0x00	0x00	0x00	0x00			
			0x11	0									Protocol successfully completed	
			0x11	1									Node-ID out of range	
			0x13	0									Protocol successfully completed	
			0x13	1									Bit timing not supported	
			0x17	0									Protocol successfully completed	
			0x17	2									Storage media access error	

Table 4: LSS commands and options

**Example: How to read a node-ID**

COB ID	Request/ Respond	DLC	Byte								Description	
			0	1	2	3	4	5	6	7		
0x7E5	Rx	8	0x04	0x01								Configuration mode global
0x7E5	Rx	8	0x5E									Inquire node-ID
0x7E4	Tx	8	0x5E	0x7F								Node-ID: 0x7F (127)

**Example: How to configure a new node-ID**

0x7E5	Rx	8	0x04	0x01								Configuration mode global
0x7E5	Rx	8	0x11	0x23								Configure new node-ID 0x23 (35)
0x7E4	Tx	8	0x11									Protocol successfully completed
0x7E5	Rx	8	0x17									Store configuration NVRAM
0x7E4	Tx	8	0x17									Protocol successfully completed
0x7E5	Rx	8	0x04									Waiting state/Normal mode
0x000	Rx	2	0x81									NMT reset node-ID

Example 1: Configuration of node-ID

**NOTICE**

The new node-ID will get active after a reset of the sensor or after a LSS communication reset command. Furthermore the following COB IDs will be automatically updated according to the pre-defined connection set of the #2 DS 301:

- SDO(Tx);
- SDO(Rx);
- Emergency;
- Error control;
- PDO1-4(Tx)

**Example: Configure the baud rate to 500 kbit/s**

COB ID	Request/ Respond	DLC	Byte								Description	
			0	1	2	3	4	5	6	7		
0x00	Rx	2	0x80	0x7F								Enter pre-operational state (node-ID 127)
0x7E5	Rx	8	0x04	0x01								Configuration mode (global) <i>(without confirmation)</i>
0x7E5	Rx	8	0x13	0x00	0x02							Set baud rate 500 kbit/s
0x7E4	Tx	8	0x13									Protocol successfully completed
0x7E5	Rx	8	0x17									Store configuration in NVRAM
0x7E4	Tx	8	0x17									Protocol successfully completed
0x7E5	Rx	8	0x04									Normal mode <i>(without confirmation)</i>

Example 2: Configure the baud rate to 500 kbit/s

**NOTICE**

The baud rate will get active after receiving the “activate bit timing parameters” command or after the “store configuration data” command with the next power-on or reset

## Emergency messages (EMCY)

Emergency objects are triggered by the incident of a CANopen device internal error situation and are transmitted onto the network. Emergency objects are suitable for error alerts. An emergency object is transmitted only once per event. Emergency objects go along with changes of the internal error status register. An emergency object consists of 8 data bytes and is built like shown (Table 5).

COB ID	Request/ Respond	DLC	Byte								Description
			0	1	2	3	4	5	6	7	
0x080 + Node-ID	Tx	8	<b>Error code</b>	<b>Register</b>	<b>Manufacturer specific error field</b>						
			0x0000								Error reset or no error
			0x3100								Main voltage (generic)
			0x5000								CANopen device hardware – generic error
			0x8100								Communication (generic)
			0x8110								CAN overrun (objects lost)
			0x8120								CAN in error or heartbeat error
			0x8130								Life guard error or heartbeat error
			0x8140								Recovered from bus off
			0x8150								CAN-ID collision
			0x8210								PDO not processed due to length error

Table 5: Error codes

Register								Hex	Description
Bit									
7	6	5	4	3	2	1	0		
Manufacturer specific	Reserved	Device profile specific	Communication error	Temperature	Voltage	Current	Generic error		
0	0	0	0	0	0	0	0	0x00	No error
0	0	0	1	0	0	0	1	0x11	Communication error
0	0	0	0	0	1	0	1	0x05	Main voltage error
1	0	0	0	0	0	0	1	0x81	Transducer error

Table 6: Error code register

**NOTICE**  
The emergency message error register is equal to the content of register 1001.

Example											
COB ID	Request/ Respond	DLC	Byte								Description
			0	1	2	3	4	5	6	7	
0x080 + Node-ID	Tx	8	0x00	0x31	0x05						Main operating voltage error generic
0x080 + Node-ID	Tx	8	0x00	0x50	0x81						Missing magnet

Example 3: Emergency message for voltage error and missing magnet

The following is a list of errors, alarms and warnings supported by the E-Series CANopen:

Class	Code	Meaning
0x31xx		Mains Voltage
	0x3100	Generic Mains Voltage Error
0x50xx		CANopen device hardware
	0x5000	Generic CANopen device hardware
0x81xx		Communication
	0x8100	Generic Communication error
	0x8110	CAN overrun
	0x8120	CAN error passive
	0x8130	CAN Lifeguard/Heartbeat error
	0x8140	CAN Bus off recover
	0x8150	CAN Bus ID Collision
0x82xx		Protocol
	0x8210	PDO not processed due to length error

Table 7: Supported emergency codes (16 bit format)

Code	Meaning
0x81	Position error (Missing magnet)
0x05	Undervoltage error
0x11	Bus warning   Bus passive   Life Guarding Event   Heartbeat Event

Table 8: Supported errors (8 bit format)

Bit	Value	Meaning
0	0x0001	Position error (Missing magnet)

Table 9: Supported alarms (16 bit format)

Bit	Value	Meaning
12	0x1000	Manufacturer specific warning 1: Poor signal
13	0x2000	Manufacturer specific warning 2: Rank signal
14	0x4000	Manufacturer specific warning 3: Supply voltage below limit

Table 10: Supported warnings (16 bit format)

### 5.5.2. Error control service

Through error control services the NMT detects failures in a CAN based network. If the error control service is enabled, the E-Series CANopen sensor transmits a heartbeat message cyclically. One or more heartbeat consumers receive the indication. The relationship between producer and consumer is configurable via the object dictionary by SDOs. By default the heartbeat is disabled. The data byte of the heartbeat message contains the current network management state of the CANopen sensor. Consider the change of the node-ID takes place after a restart of the device or “immediately”.

COB ID	Request/ Respond	DLC	Byte	Description
			0	
0x700 + Node-ID	Tx	1	<b>State</b>	
			0x00	Boot up
			0x04	Stopped
			0x05	Operational
			0x7F	Pre-operational

Table 11: Heartbeat message

## 5.6 Programming parameter

### 5.6.1. SDO download

The SDO download service is used to configure the communication, device and manufacturer specific parameters of the E-Series CANopen sensor.

COB ID	Request/ Respond	DLC	DATA							
			D0	D1	D2	D3	D4	D5	D6	D7
0x600 + Node-ID	Rx	8	0x2x	Index		Subindex	Data LSB	Data	Data	Data MSB
0x580 + Node-ID	Tx	8	0x60	Index		Subindex	0x00	0x00	0x00	0x00

Table 12: SDO download and sensor response

D0	Description
0x22	Write bytes without explicit length specification
0x23	Write 4 bytes
0x2B	Write 2 bytes
0x2F	Write 1 byte

Table 13: Explanation of the command byte “D0”

### 5.6.2. SDO upload

The SDO upload service is used to read the communication, device and manufacturer specific parameters of the E-Series CANopen sensor.

COB ID	Request/ Respond	DLC	DATA							
			D0	D1	D2	D3	D4	D5	D6	D7
0x600 + Node-ID	Rx	8	0x40	Index		Subindex	0x00	0x00	0x00	0x00
0x580 + Node-ID	Tx	8	0x4x	Index		Subindex	Data LSB	Data	Data	Data MSB

Table 14: SDO upload and sensor response

D0	Description
0x43	Upload of 4 bytes
0x4B	Upload of 2 bytes
0x4F	Upload of 1 byte

Table 15: Explanation of the response byte “D0”

### 5.6.3. SDO abort

If SDO download or SDO upload service fails for any reason, the E-Series CANopen sensor does not respond with the corresponding SDO message, but with an SDO abort protocol.

COB ID	Request/ Respond	DLC	Byte								Description
			0	1	2	3	4	5	6	7	
0x580 + Node-ID	Tx	8	0x80	Index	Subindex	Abort code					
						0x06	0x09	0x00	0x11	0x11	Subindex does not exist
						0x06	0x09	0x00	0x30	0x30	Value exceeded
						0x06	0x02	0x00	0x00	0x00	Object does not exist in the object dictionary
						0x06	0x01	0x00	0x01	0x01	Object is write only
						0x06	0x01	0x00	0x02	0x02	Attempt to write a read only object
						0x08	0x00	0x00	0x20	0x20	Data transport error
						0x08	0x00	0x00	0x00	0x00	General error
						0x08	0x00	0x00	0x22	0x22	Wrong state
						0x06	0x01	0x00	0x00	0x00	Unsupported access to an object
						0x06	0x07	0x00	0x01	0x01	Data type does not match

Table 16: SDO abort codes

### 5.6.4. SDO TPDO communication parameter: Index 1800 (PDO1) to index 1803 (PDO4)

#### Example

COB ID	Request/ Respond	DLC	Byte								Description
			0	1	2	3	4	5	6	7	
<b>Subindex 1 COB ID of the TPDO</b>											
600 + Node-ID	Rx	8	0x23	0x00	0x18	0x01	0x80 + Node-ID	0x01	0x00	0x40	Set transmission types example (11-bit CAN-ID 1FFh, no RTR allowed, valid: yes)
580 + Node-ID	Tx	8	0x60	0x00	0x18	0x01	0x00	0x00	0x00	0x00	
600 + Node-ID	Rx	8	0x40	0x00	0x18	0x01	0x00	0x00	0x00	0x00	Readout transmission types example
580 + Node-ID	Tx	8	0x43	0x00	0x18	0x01	0x80 + Node-ID	0x01	0x00	0x40	
<b>Subindex 2 transmission character</b>											
0x67F	Rx	8	0x2F	0x00	0x18	0x02	0xFE	0x00	0x00	0x00	Set transmission character "FE event-driven (manufacturer-specific)"
0x5FF	Tx	8	0x60	0x00	0x18	0x02	0x00	0x00	0x00	0x00	
0x67F	Rx	8	0x40	0x00	0x18	0x02	0x00	0x00	0x00	0x00	Readout transmission character example "FE"
0x5FF	Tx	8	0x4F	0x00	0x18	0x02	0xFE	0x00	0x00	0x00	
<b>Subindex 5 contains the event-timer</b> (The value is defined as multiple of 1 msec. A value of "0" disables the event-timer.)											
0x67F	Rx	8	0x2B	0x00	0x18	0x05	0x01	0x00	0x00	0x00	Set event timer example "1 ms"
0x5FF	Tx	8	0x60	0x00	0x18	0x05	0x00	0x00	0x00	0x00	
0x67F	Rx	8	0x40	0x00	0x18	0x05	0x00	0x00	0x00	0x00	Readout event timer example "1 ms"
0x5FF	Tx	8	0x4B	0x00	0x18	0x05	0x01	0x00	0x00	0x00	

Example 4: Configuration of Index 1800 (PDO1)

### 5.6.5. SDO PDO mapping: Index 1A00 to index 1A03

This object contains the mapping for the PDOs the device is able to transmit. Make sure to disable the dedicated PDO by setting the number of mapping entries to zero before changing it. Subindex 0x00 contains the number of valid object entries within the mapping record.

#### Example

COB ID	Request/ Respond	DLC	Byte								Description
			0	1	2	3	4	5	6	7	
0x67F	Rx	8	0x40	0x00	0x1A	0x00	0x00	0x00	0x00	0x00	Readout of amount of currently mapping PDOs "3"
0x5FF	Tx	8	0x4F	0x00	0x1A	0x00	0x03	0x00	0x00	0x00	
0x67F	Rx	8	0x2F	0x00	0x1A	0x00	0x00	0x00	0x00	0x00	Set number of application objects "0 disable"
0x5FF	Tx	8	0x60	0x00	0x1A	0x00	0x00	0x00	0x00	0x00	
<b>Subindex 1: PDO mapping for the 1st application object</b>											
0x67F	Rx	8	0x23	0x00	0x1A	0x01	0x20	0x01	0x20	0x60	Set the mapping PDO1 to Position1 "Object: Index 6020 subindex 1; length bits: 20h"
0x5FF	Tx	8	0x60	0x00	0x1A	0x01	0x00	0x00	0x00	0x00	
0x67F	Rx	8	0x40	0x00	0x1A	0x01	0x00	0x00	0x00	0x00	Readout of the mapping PDO1 to Position1 "0x60200120"
0x5FF	Tx	8	0x43	0x00	0x1A	0x01	0x20	0x01	0x20	0x60	
<b>Subindex 2: PDO mapping for the 2nd application object</b>											
0x67F	Rx	8	0x23	0x00	0x1A	0x02	0x10	0x01	0x30	0x60	Set the mapping PDO1 to Velocity1 "Object: Index 6030 subindex 1; length bits: 10h"
0x5FF	Tx	8	0x60	0x00	0x1A	0x02	0x00	0x00	0x00	0x00	
0x67F	Rx	8	0x40	0x00	0x1A	0x02	0x00	0x00	0x00	0x00	Readout of the mapping PDO1 to Velocity1 "60300110h"
0x5FF	Tx	8	0x43	0x00	0x1A	0x02	0x10	0x01	0x30	0x60	
<b>Subindex 3: PDO mapping for the 3rd application object</b>											
0x67F	Rx	8	0x23	0x00	0x1A	0x03	0x08	0x01	0x00	0x64	Set the mapping PDO1 to WorkAreaRegister, Object 0x6400, subindex 0x01, length 8 bits
0x5FF	Tx	8	0x60	0x00	0x1A	0x03	0x00	0x00	0x00	0x00	
0x67F	Rx	8	0x40	0x00	0x1A	0x03	0x00	0x00	0x00	0x00	Readout of the mapping PDO1 to WorkAreaRegister "64000108h"
0x5FF	Tx	8	0x43	0x00	0x1A	0x03	0x08	0x01	0x00	0x64	
<b>Set number of application objects</b>											
0x67F	Rx	8	0x2F	0x00	0x1A	0x00	0x03	0x00	0x00	0x00	Set number of application objects to "3"
0x5FF	Tx	8	0x60	0x00	0x1A	0x00	0x00	0x00	0x00	0x00	

Example 5: How to modify the PDO settings

### 5.6.6. SDO store parameter index 1010

Using the store parameter command, all current settings are transferred into permanent memory. The COB IDs for the emergency object and the PDOs are not stored as they are linked to and based on the node-ID. The COB IDs must be adjusted each time the sensor is restarted if other COB IDs are used for the emergency object and/or the PDOs that do not follow this scheme.

COB ID	Request/ Respond	DLC	Byte								Description
			0	1	2	3	4	5	6	7	
0x67F	Rx	8	0x22	0x10	0x10	0x01	0x73	0x61	0x76	0x65	<b>Note:</b> This takes at least 20 ms of time!
0x5FF	Tx	8	0x60	0x10	0x10	0x01	0x00	0x00	0x00	0x00	

Table 17: Store parameter and sensor response

### 5.6.7. Restore default parameters index 1011

Using the restore parameter command, all current settings are restored to default values. The COB IDs for the emergency object and the PDOs are not restored as they are linked to and based on the node-ID. The COB IDs must be adjusted each time the sensor is restarted if other COB IDs are used for the emergency object and/or the PDOs that do not follow this scheme.

COB ID	Request/ Respond	DLC	Byte								Description
			0	1	2	3	4	5	6	7	
0x67F	Rx	8	0x22	0x11	0x10	0x01	0x6C	0x6F	0x61	0x64	
0x5FF	Tx	8	0x60	0x11	0x10	0x01	0x00	0x00	0x00	0x00	

Table 18: Restore parameters

### 5.6.8. Sensor communication default parameter

These parameters are related to CANopen (C304) in section **f** “Output” of the order code (section **e** for sensor model EP2).

Index	Subindex	Description	Type	Attribute	Default value	Comment
1000		Device type	16 bit	ro	0x000A0196	Multi-sensor encoder interface   profile 406
1001		Error register	Byte	ro	State dependent	
1005		COB ID sync	Unsigned 32	rw	0x080	
1008		Device name	String	ro	ECAN	
1009		Hardware version release	String	ro	2.00	
100A		Software version release	String	ro	2.x	
100C		Guard time	Unsigned 16	rw	0	
100D		Life time factor	Unsigned 8	rw	0	
1014		EMCY ID	Unsigned 32	rw	0x080 + Node-ID	
1017		Producer heartbeat	Unsigned 16	rw	0	
1018	0	Identity object	Unsigned 8	ro	4	
	1	Vendor-ID	Unsigned 32	ro	0x00000040	Temposonics GmbH & Co. KG
	2	Product code	Unsigned 32	ro	0x0000000E	E-Series
	3	Revision number	Unsigned 32	ro	0x03090001	
	4	Serial number	Unsigned 32	ro	8-digit-serial	e.g. 70008887

Table 19: Device properties

#### Reading the serial number:

067F 8 40 18 10 04 00 00 00 00;  
05FF 8 43 18 10 04 87 88 00 70;

read 0x1018:4  
serial number “0x70008887”

### 5.6.9. PDO mapping

Index	Subindex	Description	Type	Attribute	Default Value	Description
<b>Process Data Object (PDO1)</b>						
1800	0	Transmit 1st PDO	Unsigned 8	ro	5	Number of largest subindex
	1	COB ID used by PDO1	Unsigned 32	rw	0x40000180 + Node-ID	PDO enabled
	2	Transmission type	Unsigned 8	rw	0xFE	254 (event-driven)
	3	Inhibit time	Unsigned 16	rw	0x0000	
	5	Event timer	Unsigned 16	rw	1	msec
1A00	0	1st transmit PDO mapping	Unsigned 8	rw	3	Number of largest subindex
	1	1st application object	Unsigned 32	rw	0x60200120	Position
	2	2nd application object	Unsigned 32	rw	0x60300110	Velocity
	3	3rd application object	Unsigned 32	rw	0x64000108	Work area state reg.
<b>Process Data Object (PDO2)</b>						
1801	0	Transmit 2nd PDO	Unsigned 8	ro	5	Number of largest subindex
	1	COB ID used by PDO2	Unsigned 32	rw	0xC0000280 + Node-ID	PDO disabled
	2	Transmission type	Unsigned 8	rw	0xFE	254 (event-driven)
	3	Inhibit time	Unsigned 16	rw	0x0000	
	5	Event timer	Unsigned 16	rw	1	msec
1A01	0	2nd transmit PDO mapping	Unsigned 8	rw	3	Number of largest subindex
	1	1st application object	Unsigned 32	rw	0x60200220	Position
	2	2nd application object	Unsigned 32	rw	0x60300210	Velocity
	3	3rd application object	Unsigned 32	rw	0x64000208	Work area state reg.
<b>Process Data Object (PDO3)</b>						
1802	0	Transmit 3rd PDO	Unsigned 8	ro	5	Number of largest subindex
	1	COB ID used by PDO3	Unsigned 32	rw	0xC0000380 + Node-ID	PDO disabled
	2	Transmission type	Unsigned 8	rw	0xFE	254 (event-driven)
	3	Inhibit time	Unsigned 16	rw	0x0000	
	5	Event timer	Unsigned 16	rw	1	msec
1A02	0	3rd transmit PDO mapping	Unsigned 8	rw	3	Number of largest subindex
	1	1st application object	Unsigned 32	rw	0x60200320	Position
	2	2nd application object	Unsigned 32	rw	0x60300310	Velocity
	3	3rd application object	Unsigned 32	rw	0x64000308	Work area state reg.
<b>Process Data Object (PDO4)</b>						
1803	0	Transmit 4th PDO	Unsigned 8	ro	5	Number of largest subindex
	1	COB ID used by PDO4	Unsigned 32	rw	0xC0000480 + Node-ID	PDO disabled
	2	Transmission type	Unsigned 8	rw	0xFE	254 (event-driven)
	3	Inhibit time	Unsigned 16	rw	0x0000	
	5	Event timer	Unsigned 16	rw	1	msec
1A03	0	4th transmit PDO mapping	Unsigned 8	rw	3	Number of largest subindex
	1	1st application object	Unsigned 32	rw	0x60200420	Position
	2	2nd application object	Unsigned 32	rw	0x60300410	Velocity
	3	3rd application object	Unsigned 32	rw	0x64000408	Work area state reg.

Table 20: PDO configuration

The following objects can be mapped:

- 6020: Position
- 6030: Velocity
- 6300: CAM state
- 6400: Work area state
- 6503: Alarms

As described in Table 16 on page 34, a maximum of 3 objects can be arranged during PDO mapping.

### 5.6.10. Device properties according to CiA DS 406

Index	Subindex	Description	Type	Attribute	Default Value	Description
6000		Operating parameter	Unsigned 16	rw	0x0000	Scaling fix
6002		Total measuring range	Unsigned 32	rw	Sensor specific	Stroke length in measuring units
6005	0	Linear encoder measuring step settings	Unsigned 8	ro	2	Number of objects
	1	Position measuring step	Unsigned 32	ro	Resolution dependend	Position step in 0.001 µm
	2	Velocity measuring step	Unsigned 32	ro	100	Velocity step in 0.01 mm/s
6200		Cyclic timer	Unsigned 16	rw	0x01	Cycle time in msec
6500		Operating status	Unsigned 16	ro	0x0000	
6501		Measuring step	Unsigned 32	ro	Resolution dependend	Measuring step in 0.001 µm
6503		Alarms occurred	Unsigned 16	ro	0x0000	
6504		Alarms supported	Unsigned 16	ro	0x0001	
6505		Warning occurred	Unsigned 16	ro	0x0000	
6506		Warning supported	Unsigned 16	ro	0x7000	
6507		Profile and software version	Unsigned 32	ro	0x02170302*	
6508		Operation time	Unsigned 32	ro	FF FF FF FF	Not supported
650A	0	Module identification	Unsigned 8	ro	3	Number of objects
	1	Manufacturer offset value	Integer 32	ro	Sensor specific	Sensor units
	2	Manufacturer min. position value	Integer 32	ro	Start position	Sensor units
	3	Manufacturer max. position value	Integer 32	ro	Max. position	Sensor units
650B		Serial number	Unsigned 32	ro	8-digit-serial	e.g. 70008887
650E		Device capability	Unsigned 32	ro	2	Encoder class 2

Table 21: Device properties

\* / at the time of publication

### 5.6.11. Cam Channels

Index	Subindex	Description	Type	Attribute	Default Value	Description
<b>Cam Channel 1</b>						
6010	1	Preset value channel 1	Integer 32	rw	0	Sensor units, clear preset with 0xFFFFFFFF
6020	1	Position value channel 1	Integer 32	ro		Current position in sensor units
6030	1	Velocity value channel 1	Integer 16	ro		Current velocity in sensor units
6300	1	Cam state channel 1	Unsigned 8	ro		
6301	1	Cam enable channel 1	Unsigned 8	rw	0	
6302	1	Cam polarity channel 1	Unsigned 8	rw	0	
6310	1	Cam1 low limit channel 1	Integer 32	rw	0	
6311	1	Cam2 low limit channel 1	Integer 32	rw	0	
6312	1	Cam3 low limit channel 1	Integer 32	rw	0	
6313	1	Cam4 low limit channel 1	Integer 32	rw	0	
650C	1	Offset value for multi sensor devices	Integer 32	ro	0	
6400	1	Work area state channel 1	Unsigned 8	ro		
6401	1	Work area low limit channel 1	Integer 32	rw	0	Sensor units
6402	1	Work area high limit channel 1	Integer 32	rw	1	Sensor units
<b>Cam Channel 2</b>						
6010	2	Preset value channel 2	Integer 32	rw	0	Sensor units, clear preset with 0xFFFFFFFF
6020	2	Position value channel 2	Integer 32	ro		Current position in sensor units
6030	2	Velocity value channel 2	Integer 16	ro		Current velocity in sensor units
6300	2	Cam state channel 2	Unsigned 8	ro		
6301	2	Cam enable channel 2	Unsigned 8	rw	0	
6302	2	Cam polarity channel 2	Unsigned 8	rw	0	
6310	2	Cam1 low limit channel 2	Integer 32	rw	0	
6311	2	Cam2 low limit channel 2	Integer 32	rw	0	
6312	2	Cam3 low limit channel 2	Integer 32	rw	0	
6313	2	Cam4 low limit channel 2	Integer 32	rw	0	
650C	2	Offset value for multi sensor devices	Integer 32	ro	0	
6400	2	Work area state channel 2	Unsigned 8	ro		
6401	2	Work area low limit channel 2	Integer 32	rw	0	Sensor units
6402	2	Work area high limit channel 2	Integer 32	rw	1	Sensor units

Table 22: Cam/work area configuration

Index	Subindex	Description	Type	Attribute	Default Value	Description
<b>Cam Channel 3</b>						
6010	3	Preset value channel 3	Integer 32	rw	0	Sensor units, clear preset with 0xFFFFFFFF
6020	3	Position value channel 3	Integer 32	ro		Current position in sensor units
6030	3	Velocity value channel 3	Integer 16	ro		Current velocity in sensor units
6300	3	Cam state channel 3	Unsigned 8	ro		
6301	3	Cam enable channel 3	Unsigned 8	rw	0	
6302	3	Cam polarity channel 3	Unsigned 8	rw	0	
6310	3	Cam1 low limit channel 3	Integer 32	rw	0	
6311	3	Cam2 low limit channel 3	Integer 32	rw	0	
6312	3	Cam3 low limit channel 3	Integer 32	rw	0	
6313	3	Cam4 low limit channel 3	Integer 32	rw	0	
650C	3	Offset value for multi sensor devices	Integer 32	ro	0	
6400	3	Work area state channel 3	Unsigned 8	ro		
6401	3	Work area low limit channel 3	Integer 32	rw	0	Sensor units
6402	3	Work area high limit channel 3	Integer 32	rw	1	Sensor units
<b>Cam Channel 4</b>						
6010	4	Preset value channel 4	Integer 32	rw	0	Sensor units, clear preset with 0xFFFFFFFF
6020	4	Position value channel 4	Integer 32	ro		Current position in sensor units
6030	4	Velocity value channel 4	Integer 16	ro		Current velocity in sensor units
6300	4	Cam state channel 4	Unsigned 8	ro		
6301	4	Cam enable channel 4	Unsigned 8	rw	0	
6302	4	Cam polarity channel 4	Unsigned 8	rw	0	
6310	4	Cam1 low limit channel 4	Integer 32	rw	0	
6311	4	Cam2 low limit channel 4	Integer 32	rw	0	
6312	4	Cam3 low limit channel 4	Integer 32	rw	0	
6313	4	Cam4 low limit channel 4	Integer 32	rw	0	
650C	4	Offset value for multi sensor devices	Integer 32	ro	0	
6400	4	Work area state channel 4	Unsigned 8	ro		
6401	4	Work area low limit channel 4	Integer 32	rw	0	Sensor units
6402	4	Work area high limit channel 4	Integer 32	rw	1	Sensor units

Table 23: Cam/work area configuration

## 5.7 Process data

### Transmission the data

The transmission type object (index 1800 ff subindex 2) enables to switch between the different transmission modes synchronous and event-driven mode.

#### 5.7.1. Synchronous mode

When the E-Series CANopen sensor is in NMT operational state and the transmission type (Index 1800 ff subindex 2) is between  $n = 0 \dots 240$ , the synchronous mode is enabled. The PDO is transmitted by the CANopen sensor after receiving every  $n$ th sync object. The sync object has the following format:

COB ID	Rx/Tx	DLC	DATA							
			D0	D1	D2	D3	D4	D5	D6	D7
0x080	Rx	0	-	-	-	-	-	-	-	-

Table 24: Sync object

#### NOTICE

The COB ID of the sync object message can be programmed individually with index 1005.  
So the COB ID of the sync message may be different, depending on the configuration of the sensor.

#### 5.7.2. Event-driven mode

When the E-Series CANopen sensor is in NMT operational state and the transmission type (Index 1800 ff subindex 2) is 254 or 255, the event-driven mode is enabled. The PDO is transmitted by the sensor after the event timer (Index 1800 ff subindex 5) is expired. The value of the timer is given in ms.

#### 5.7.3. PDO message format

Table 25 describes the default format of the E-Series CAN sensor PDO message. The current PDO mapping can be seen at Index 1A00 ff.

COB ID	Rx/Tx	DLC	DATA							
			D0	D1	D2	D3	D4	D5	D6	D7
0x180 + Node-ID	Tx	6	Pos LSB	Pos	Pos	Pos MSB	Velocity LSB	Velocity MSB	Status	-

Table 25: Default PDO format

#### NOTICE

For the PDO message the measuring steps for the position (Pos) and velocity values can be read with object linear encoder measuring step settings (Index 6005).

#### 5.7.4. PDO transmission time consideration

For the configuration of the network it is helpful to estimate the time of data transmission. According to the physical cable length the baud rate of the data transmission is limited. Furthermore the event timer interval indicates how often PDOs are generated. The number of PDOs generated by the slave double the time required for these continues transmission.

In case of default PDO mapping (hosting 1 PDO with 4 byte position, 2 byte velocity and 1 byte for status data) the CAN message becomes 103...126 bits (depending on stuff bit count).

Data transmission times depends on the baud rate in the network assuming default PDO mapping.

Baud rate [kbaud]	Time [ $\mu$ s]
125	824 ... 1004
250	412 ... 502
500	206 ... 251
1000	103 ... 125.5

Table 26: Data transmission times

#### 5.7.5. Cam switch

The sensor enables a cam switch depending on the position of the magnet. When the magnet passes the switch position, the cam is activated or inactivated respectively.

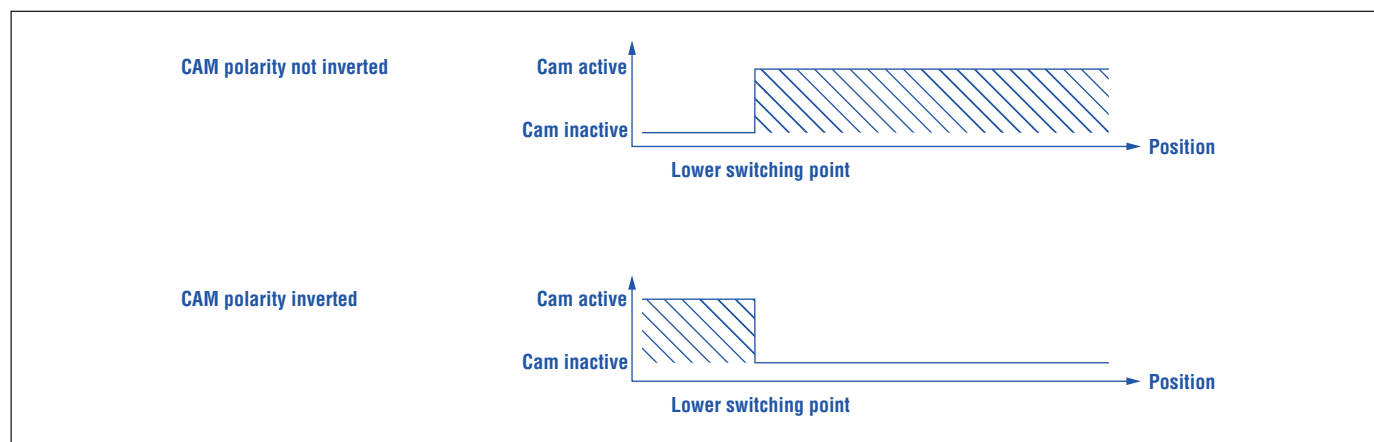

Fig. 29: CAM switch

## 6. Maintenance and troubleshooting

### 6.1 Error conditions, troubleshooting

See chapter “5. Commissioning” on page 25.

### 6.2 Maintenance

The sensor is maintenance-free.

### 6.3 Repair

Repairs of the sensor may be performed only by Temposonics or a repair facility explicitly authorized by Temposonics. For return see chapter “2.6 Return” on page 4.

### 6.4 List of spare parts

No spare parts are available for this sensor.

### 6.5 Transport and storage

The conditions of transport and storage of the sensor match the operating conditions mentioned in this document.

## 7. Removal from service/dismantling

The product contains electronic components and must be disposed of in accordance with the local regulations.

## 8. Technical data

### 8.1 Technical data of Temposonics® EH

Output	
Interface	CAN System ISO 11898
Data protocol	CANopen: CiA Standard DS 301 V3.0/encoder profile DS 406 V3.2
Baud rate, kBit/s	1000    500    250    125    50    20
Cable length, m	< 25   < 100   < 250   < 500   < 1000   < 2500
	The sensor will be supplied with ordered baud rate, changeable by customer via LSS
Measured value	Position, velocity/option: Multi-position measurement (2 positions)
Measurement parameters	
Resolution	10 µm, 20 µm
Velocity	1 mm/s
Cycle time	1 ms
Linearity deviation <sup>5</sup>	≤ ±0.02 % F.S. (minimum ±60 µm)
Repeatability	≤ ±0.005 % F.S. (minimum ±20 µm)
Operating conditions	
Operating temperature	-40...+75 °C (-40...+167 °F)
Humidity	90 % relative humidity, no condensation
Ingress protection	IP67/IP69K for connector outlet (connectors correctly fitted) and for cable outlet
Shock test	100 g (single shock), IEC standard 60068-2-27
Vibration test	15 g/10...2000 Hz, IEC standard 60068-2-6 (excluding resonant frequencies)
EMC test	Electromagnetic emission according to EN 61000-6-3 Electromagnetic immunity according to EN 61000-6-2 The EH sensors fulfill the requirements of the EMC directives 2014/30/EU and UKSI 2016 No. 1091
Operating pressure	7 mm (0.28 in.) rod Ø: 300 bar (4351 psi), 450 bar (6527 psi) peak 10 mm (0.39 in.) rod Ø: 350 bar (5076 psi), 530 bar (7687 psi) peak
Magnet movement velocity	Any
Design/Material	
Sensor electronics housing	Stainless steel 1.4305 (AISI 303); option: Stainless steel 1.4404 (AISI 316L)
Sensor flange	Stainless steel 1.4305 (AISI 303); option: Stainless steel 1.4404 (AISI 316L)
Sensor rod	7 mm (0.28 in.) rod Ø: Stainless steel 1.4301 (AISI 304) 10 mm (0.39 in.) rod Ø: Stainless steel 1.4306 (AISI 304L); option: Stainless steel 1.4404 (AISI 316L)
RoHS compliance	The used materials are compliant with the requirements of EU directive 2011/65/EU and EU regulation 2015/863 as well as UKSI 2022 No. 622 with amendments
Stroke length	50...2540 mm (2...100 in.)
Mechanical mounting	
Mounting position	Any
Electrical connection	
Connection type	M12 male connector (5 pin)
Operating voltage	+24 VDC (-15/+20 %); The EH sensors must be power supplied via an external Class 2 power source in accordance with the UL approval
Ripple	≤ 0.28 V <sub>pp</sub>
Current consumption	40...60 mA (depending on stroke length)
Dielectric strength	500 VDC (DC ground to machine ground)
Polarity protection	Up to -30 VDC
Overvoltage protection	Up to 36 VDC

8.2 Technical data of Temposonics® EP/EL	
<b>Output</b>	
Interface	CAN System ISO 11898
Data protocol	CANopen: CiA Standard DS 301 V3.0/encoder profile DS 406 V3.1
Baud rate, kBit/s	1000    500    250    125    50    20
Cable length, m	< 25   < 100   < 250   < 500   < 1000   < 2500
	The sensor will be supplied with ordered baud rate, changeable by customer via LSS
Measured value	Position, velocity/option: Multi-position measurement (2 positions)
<b>Measurement parameters</b>	
Resolution	10 µm, 20 µm
Velocity	1 mm/s
Cycle time	1 ms
Linearity deviation <sup>6</sup>	≤ ±0.02 % F.S. (minimum ±60 µm)
Repeatability	≤ ±0.005 % F.S. (minimum ±20 µm)
<b>Operating conditions</b>	
Operating temperature	-40...+75 °C (-40...+167 °F)
Humidity	90 % relative humidity, no condensation
Ingress protection <sup>7</sup>	IP67 for connector outlet (connectors correctly fitted)
Shock test	100 g (single shock), IEC standard 60068-2-27
Vibration test	15 g/10...2000 Hz, IEC standard 60068-2-6 (excluding resonant frequencies)
EMC test	Electromagnetic emission according to EN 61000-6-3 Electromagnetic immunity according to EN 61000-6-2 The EP/EL sensors fulfill the requirements of the EMC directives 2014/30/EU and UKSI 2016 No. 1091
Magnet movement velocity	Magnet slider: ≤ 5 m/s; U-magnet: Any; block magnet: Any
<b>Design/Material</b>	
Sensor electronics housing	Aluminum
Sensor profile	Aluminum
RoHS compliance	The used materials are compliant with the requirements of EU directive 2011/65/EU and EU regulation 2015/863 as well as UKSI 2022 No. 622 with amendments
Stroke length	50...2540 mm (2...100 in.)
<b>Mechanical mounting</b>	
Mounting position	Any
<b>Electrical connection</b>	
Connection type	M12 male connector (5 pin)
Operating voltage	+24 VDC (-15/+20 %); The EP/EL sensors must be power supplied via an external Class 2 power source in accordance with the UL approval
Ripple	≤ 0.28 V <sub>pp</sub>
Current consumption	40...60 mA (depending on stroke length)
Dielectric strength	500 VDC (DC ground to machine ground)
Polarity protection	Up to -30 VDC
Overvoltage protection	Up to 36 VDC

6/ With magnet slider # 252 182 and # 252 184, U-magnet # 251 416-2

7/ The IP rating IP67 is only valid for the sensor electronics housing, as water and dust can get inside the profile.

### 8.3 Technical data of Temposonics® EP2

Output						
Interface	CAN System ISO 11898					
Data protocol	CANopen: CiA Standard DS 301 V3.0/encoder profile DS 406 V3.1					
Baud rate, kBit/s	1000	500	250	125	50	20
Cable length, m	< 25	< 100	< 250	< 500	< 1000	< 2500
Measured variable	The sensor will be supplied with ordered baud rate, changeable by customer via LSS Position, velocity/option: Multi-position measurement (2 positions)					
Measurement parameters						
Resolution	10 µm, 20 µm					
Velocity	1 mm/s					
Cycle time	1 ms					
Linearity deviation <sup>8</sup>	≤ ±0.02 % F.S. (minimum ±90 µm)					
Repeatability	≤ ±0.005 % F.S. (minimum ±20 µm)					
Operating conditions						
Operating temperature	-40...+75 °C (-40...+167 °F)					
Humidity	90 % relative humidity, no condensation					
Ingress protection <sup>9</sup>	IP67 for connector outlet (connectors correctly fitted)					
Shock test	100 g (single shock), IEC standard 60068-2-27					
Vibration test	8 g/10...2000 Hz, IEC standard 60068-2-6 (excluding resonant frequencies)					
EMC test	Electromagnetic emission according to EN 61000-6-3 Electromagnetic immunity according to EN 61000-6-2 The EP2 sensors fulfill the requirements of the EMC directives 2014/30/EU and UKSI 2016 No. 1091					
Magnet movement velocity	Any					
Design/Material						
Sensor lid	Zinc die-cast					
Sensor profile	Aluminum					
RoHS compliance	The used materials are compliant with the requirements of EU directive 2011/65/EU and EU regulation 2015/863 as well as UKSI 2022 No. 622 with amendments					
Stroke length	50...2540 mm (2...100 in.)					
Mechanical mounting						
Mounting position	Any					
Electrical connection						
Connection type	M12 male connector (5 pin)					
Operating voltage	+24 VDC (-15/+20 %); The EP2 sensors must be power supplied via an external Class 2 power source in accordance with the UL approval					
Ripple	≤ 0.28 V <sub>pp</sub>					
Current consumption	40...60 mA (depending on stroke length)					
Dielectric strength	500 VDC (DC ground to machine ground)					
Polarity protection	Up to -30 VDC					
Overvoltage protection	Up to 36 VDC					

8/ With block magnet # 403 448

9/ The IP rating IP67 is only valid for the sensor electronics housing, as water and dust can get inside the profile.

#### 8.4 Technical data of Temposonics® ER

Output	
Interface	CAN System ISO 11898
Data protocol	CANopen: CiA Standard DS 301 V3.0/encoder profile DS 406 V3.1
Baud rate, kBit/s	1000    500    250    125    50    20
Cable length, m	< 25   < 100   < 250   < 500   < 1000   < 2500
	The sensor will be supplied with ordered baud rate, changeable by customer via LSS
Measured value	Position, velocity
Measurement parameters	
Resolution	10 µm, 20 µm
Velocity	1 mm/s
Cycle time	1 ms
Linearity deviation	≤ ±0.02 % F.S. (minimum ±60 µm)
Repeatability	≤ ±0.005 % F.S. (minimum ±20 µm)
Operating conditions	
Operating temperature	-40...+75 °C (-40...+167 °F)
Humidity	90 % relative humidity, no condensation
Ingress protection <sup>10</sup>	IP67 for connector outlet (connectors correctly fitted)
Shock test	100 g (single shock), IEC standard 60068-2-27
Vibration test	5 g/10...2000 Hz, IEC standard 60068-2-6 (excluding resonant frequencies)
EMC test	Electromagnetic emission according to EN 61000-6-3 Electromagnetic immunity according to EN 61000-6-2 The ER sensors fulfill the requirements of the EMC directives 2014/30/EU and UKSI 2016 No. 1091
Magnet movement velocity	≤ 5 m/s
Design/Material	
Sensor electronics housing	Aluminum
Guided driving rod	Aluminum
RoHS compliance	The used materials are compliant with the requirements of EU directive 2011/65/EU and EU regulation 2015/863 as well as UKSI 2022 No. 622 with amendments
Stroke length	50...1500 mm (2...60 in.)
Mechanical mounting	
Mounting position	Any
Electrical connection	
Connection type	M12 male connector (5 pin)
Operating voltage	+24 VDC (-15/+20 %); The ER sensors must be power supplied via an external Class 2 power source in accordance with the UL approval
Ripple	≤ 0.28 V <sub>PP</sub>
Current consumption	40...60 mA (depending on stroke length)
Dielectric strength	500 VDC (DC ground to machine ground)
Polarity protection	Up to -30 VDC
Overvoltage protection	Up to 36 VDC

<sup>10</sup>/The IP rating IP67 is only valid for the sensor electronics housing, as water and dust can get inside the profile.

## 9. Appendix – Safety declaration

Dear Customer,

If you return one or several sensors for checking or repair, we need you to sign a safety declaration. The purpose of this declaration is to ensure that the returned items do not contain residues of harmful substances and/or that people handling these items will not be in danger.

Temposonics order code: \_\_\_\_\_ Sensor model(s): \_\_\_\_\_

Serial number(s): \_\_\_\_\_ Stroke length(s): \_\_\_\_\_

**The sensor has been in contact with the following materials:**

Do not specify chemical formulas.  
 Please include safety data sheets of the substances, if applicable.

In the event of suspected penetration of substances into the sensor, consult Temposonics to determine measures to be taken before shipment.

**Short description of malfunction:**

**Corporate information**

Company: \_\_\_\_\_

Address: \_\_\_\_\_

\_\_\_\_\_

**Contact partner**

Phone: \_\_\_\_\_

Fax: \_\_\_\_\_

Email: \_\_\_\_\_

We hereby certify that the measuring equipment has been cleaned and neutralized.  
 Equipment handling is safe. Personnel exposure to health risks during transport and repair is excluded.

Stamp

Signature

Date

**Temposonics, LLC** Tel. +1 919 677-0100  
 3001 Sheldon Drive Fax +1 (919) 677-0200  
 Cary, N.C. 27513 info.us@temposonics.com  
 United States www.temposonics.com

**Temposonics GmbH & Co.KG** Tel. +49 2351/95 87-0  
 Auf dem Schüffel 9 Fax. +49 2351/56 49 1  
 58513 Lüdenscheid info.de@temposonics.com  
 Germany www.temposonics.com

**UNITED STATES**  
**Temposonics, LLC**  
Americas & APAC Region  
3001 Sheldon Drive  
Cary, N.C. 27513  
Phone: +1 919 677-0100  
E-mail: [info.us@temposonics.com](mailto:info.us@temposonics.com)

**GERMANY**  
**Temposonics**  
**GmbH & Co. KG**  
EMEA Region & India  
Auf dem Schüffel 9  
58513 Lüdenscheid  
Phone: +49 2351 9587-0  
E-mail: [info.de@temposonics.com](mailto:info.de@temposonics.com)

**ITALY**  
Branch Office  
Phone: +39 030 988 3819  
E-mail: [info.it@temposonics.com](mailto:info.it@temposonics.com)

**FRANCE**  
Branch Office  
Phone: +33 6 14 060 728  
E-mail: [info.fr@temposonics.com](mailto:info.fr@temposonics.com)

**UK**  
Branch Office  
Phone: +44 79 21 83 05 86  
E-mail: [info.uk@temposonics.com](mailto:info.uk@temposonics.com)

**SCANDINAVIA**  
Branch Office  
Phone: +46 70 29 91 281  
E-mail: [info.sca@temposonics.com](mailto:info.sca@temposonics.com)

**CHINA**  
Branch Office  
Phone: +86 21 3405 7850  
E-mail: [info.cn@temposonics.com](mailto:info.cn@temposonics.com)

**JAPAN**  
Branch Office  
Phone: +81 3 6416 1063  
E-mail: [info.jp@temposonics.com](mailto:info.jp@temposonics.com)

**Document Part Number:**  
551774 Revision B (EN) 05/2026



**temposonics.com**