

## Data Sheet

### ER SSI

#### Magnetostrictive Linear Position Sensors

- Compact sensor model
- Operating temperature up to +75 °C (+167 °F)
- Ideal for flexible mounting

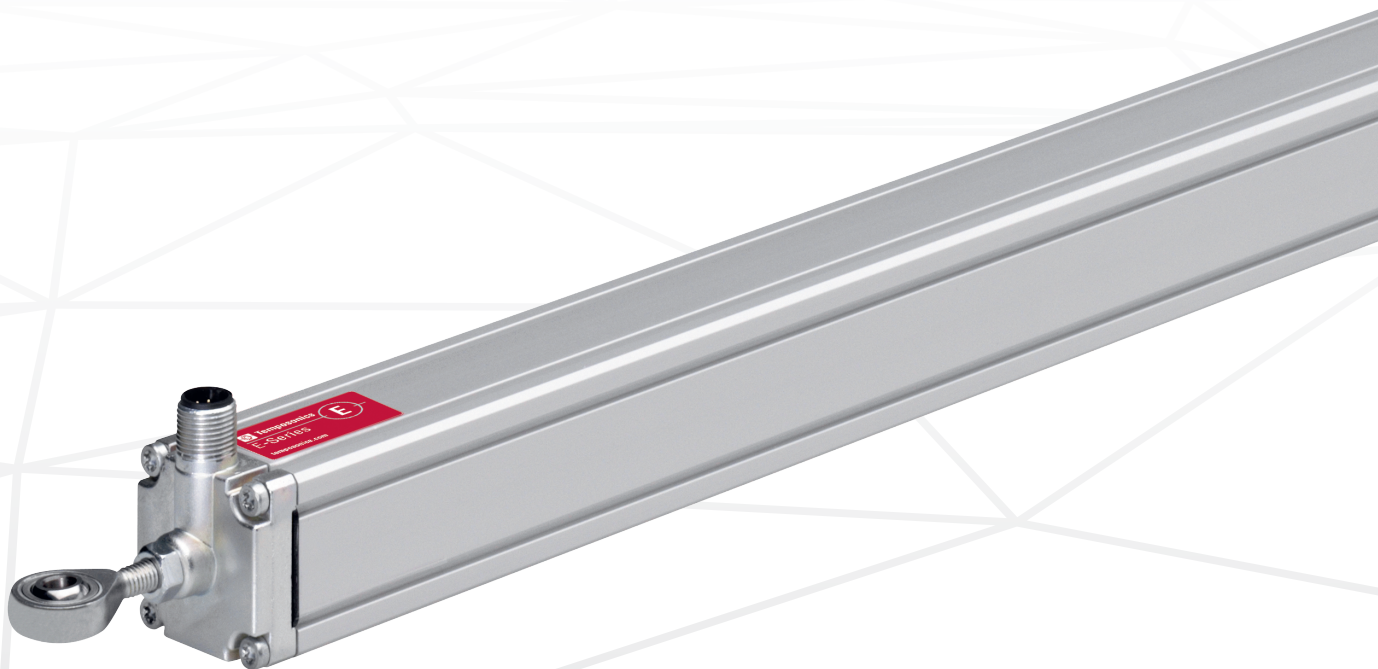

## MEASURING TECHNOLOGY

The absolute, linear position sensors provided by Temposonics rely on the company's proprietary magnetostrictive technology, which can determine position with a high level of precision and robustness. Each Temposonics position sensor consists of a ferromagnetic waveguide, a position magnet, a strain pulse converter and supporting electronics. The magnet, connected to the object in motion in the application, generates a magnetic field at its location on the waveguide. A short current pulse is applied to the waveguide. This creates a momentary radial magnetic field and torsional strain on the waveguide. The momentary interaction of the magnetic fields releases a torsional strain pulse that propagates the length of the waveguide. When the ultrasonic wave reaches the end of the waveguide it is converted into an electrical signal. Since the speed of the ultrasonic wave in the waveguide is precisely known, the time required to receive the return signal can be converted into a linear position measurement with both high accuracy and repeatability.

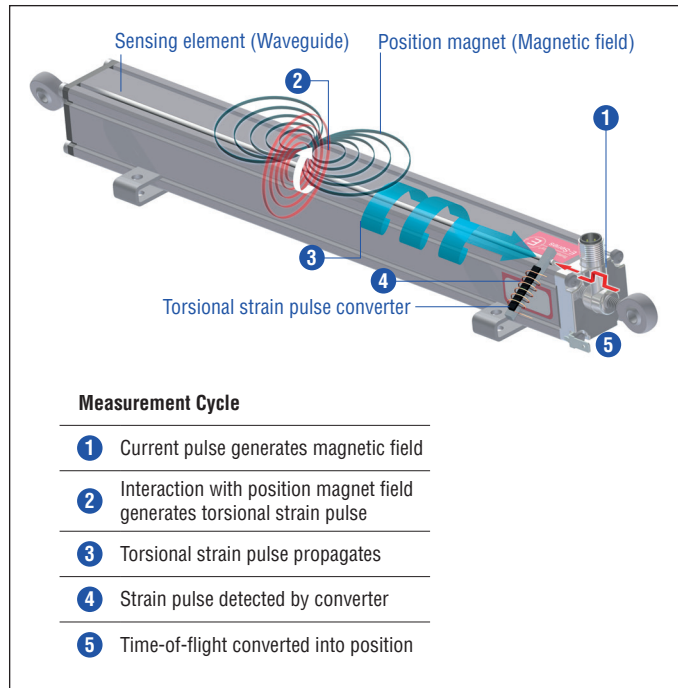

Fig. 1: Time-of-flight based magnetostrictive position sensing principle

## ER SENSOR

Robust, non-contact and wear free, the Temposonics linear position sensors provide the best durability and precise position measurement feedback in harsh industrial environments. Measurement accuracy is tightly controlled by the quality of the waveguide manufactured exclusively by Temposonics.

The Temposonics® ER has an aluminum rod-and-cylinder design where the rod can extend and retract from the sensor housing to measure linear position. Inside, a magnet is secured to the end of the rod and remains protected within the sensor electronics housing. Accessory rod ends are available for attaching the rod to the machine's moving part. The rod-and-cylinder sensor design can be installed in any orientation, and provides a convenient and versatile position feedback solution. Typical fields of applications are printing and paper industry, machine tools and plastics industry as well as control systems.



Fig. 2: Typical application: Paper industry

## TECHNICAL DATA

Output					
Interface	SSI (Synchronous Serial Interface)				
Data format	Binary or gray				
Data length	24, 25 bit				
Data transmission rate	70 kBaud*...1 MBaud, dependent on cable length:				
	Cable length	< 3 m	< 50 m	< 100 m	< 200 m   < 400 m
	Baud rate	1,0 MBd	< 400 kBd	< 300 kBd	< 200 kBd   < 100 kBd
Measured value	Position				
Measurement parameters					
Resolution	20 µm, 50 µm or 100 µm				
Cycle time	Stroke length	300 mm	750 mm	1000 mm	2000 mm
	Measurement rate	3,7 kHz	3,0 kHz	2,3 kHz	1,2 kHz
Linearity	≤ ±0.02 % F.S. (minimum ±60 µm)				
Repeatability	≤ ±0.005 % F.S. (minimum ±20 µm)				
Operating conditions					
Operating temperature	−40...+75 °C (−40...+167 °F)				
Humidity	90 % reative humidity, no condensation				
Ingress protection <sup>1,2</sup>	IP67 (connectors correctly fitted)				
Shock test	100 g (single shock) IEC standard 60068-2-27				
Vibration test	5 g / 10...2000 Hz IEC standard 60068-2-6 (resonance frequencies excluded)				
EMC test	Electromagnetic emission according to EN 61000-6-3				
	Electromagnetic immunity according to EN 61000-6-2				
	The sensor meets the requirements of the EC directives and is marked with 				
Magnet movement velocity	≤ 5 m/s				
Design / Material					
Sensor electronics housing	Aluminum				
Guided driving rod	Aluminum				
Stroke length	50...1500 mm (2...60 in.)				
Mechanical mounting					
Mounting position	Any				
Mounting instruction	Please consult the technical drawings and the brief instructions (document number: <a href="#">551684</a> )				
Electrical connection					
Connection type	M12 (8 pin) male connector				
Operating voltage	+24 VDC (−15 / +20 %); UL recognition requires an approved power supply with energy limitation (UL 61010-1), or Class 2 rating according to the National Electrical Code (USA) / Canadian Electrical Code.				
Ripple	≤ 0.28 V <sub>pp</sub>				
Current consumption	Typ. 90 mA				
Dielectric strength	500 VDC (DC ground to machine ground)				
Polarity protection	Up to −30 VDC				
Overvoltage protection	Up to 36 VDC				

\* / With standard one shot of 16 µs.

1 / The IP rating is not part of the UL recognition.

2 / The IP rating IP67 is only valid for the sensor electronics housing, as water and dust can get inside the profile.

## TECHNICAL DRAWING

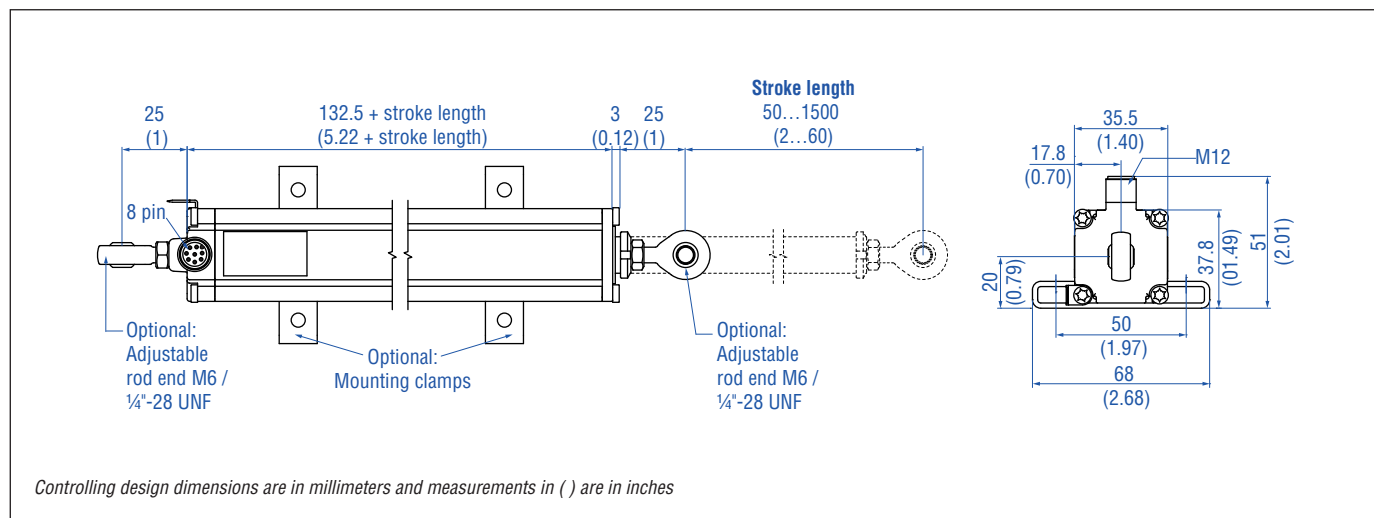

Fig. 3: Temposonics® ER

## CONNECTOR WIRING

D84		
Signal + power supply		
M12 male connector (A-coded)	Pin	Function
<p>View on sensor</p>	1	Clock (+)
	2	Clock (-)
	3	Data (+)
	4	Data (-)
	5	Not connected
	6	Not connected
	7	+24 VDC (-15 / +20 %)
	8	DC Ground (0 V)

Fig. 4: Connector wiring D84

**FREQUENTLY ORDERED ACCESSORIES** – Additional options available in our [Accessories Guide](#) 551444

Cable connectors <sup>3</sup>		Cord sets	
<p><b>M12 A-coded female connector (8 pin), straight</b> Part no. 370 694</p>	<p><b>M12 A-coded female connector (8 pin), angled</b> Part no. 370 699</p>	<p><b>Cable with M12 A-coded female connector (8 pin), straight – pigtail</b> Part no. 370 674</p>	<p><b>Cable with M12 A-coded female connector (8 pin), angled – pigtail</b> Part no. 370 676</p>
<p>Housing: GD-ZnAL Termination: Screw Contact insert: CuZn Cable Ø: 4...9 mm (0.16...0.35 in.) Wire: 0.75 mm<sup>2</sup> Operating temperature: -25...+90 °C (-13...+194 °F) Ingress protection: IP67 (correctly fitted) Fastening torque: 0.6 Nm</p>	<p>Housing: GD-ZnAL Termination: Screw Contact insert: CuZn Cable Ø: 6...8 mm (0.24...0.31 in.) Wire: 0.5 mm<sup>2</sup> Operating temperature: -25...+85 °C (-13...+185 °F) Ingress protection: IP67 (correctly fitted) Fastening torque: 0.6 Nm</p>	<p>Material: PUR jacket; black Features: Shielded Cable length: 5 m (16.4 ft) Ingress protection: IP67, IP69K (correctly fitted) Operating temperature: -25...+80 °C (-13...+176 °F)</p>	<p>Cable: Shielded Cable length: 5 m (16.4 ft) Ingress protection: IP67 (correctly fitted)</p>

Rod ends		Mounting clamp
<p><b>Rod end with M6 thread</b> Part no. 254 210</p>	<p><b>Rod end with 1/4"-28 UNF thread</b> Part no. 254 235</p>	<p><b>Mounting clamp</b> Part no. 403 508</p>
<p>Material: Galvanized steel</p>	<p>Material: Galvanized steel</p>	<p>Material: Stainless steel 1.4301/1.4305 (AISI 304/303)</p>

<sup>3</sup> Follow the manufacturer's mounting instructions  
Controlling design dimensions are in millimeters and measurements in ( ) are in inches

## ORDER CODE

1	2	3	4	5	6	7	8	9	10	11	12	13	14	15	16	17	18	19	
E	R							D	8	4	1	S					1	0	0
a		b	c					d			e	f							

<b>a</b>	<b>Sensor model</b>
E R	Aluminum cylinder with a guided driving rod

<b>b</b>	<b>Design</b>
M	Inside thread M6 at end of rod (For metric stroke length measurement)
S	Inside thread 1/4"-28 UNF at end of rod (For US customary stroke length measurement)

<b>c</b>	<b>Stroke length</b>
X X X X M	0050...1500 mm
<b>Standard stroke length (mm)*</b>	
50 ... 500 mm	25 mm
500...1500 mm	50 mm
X X X X U	002.0...060.0 in.
<b>Standard stroke length (in.)*</b>	
2...22 in.	1.0 in.
22...60 in.	2.0 in.

<b>d</b>	<b>Connection type</b>
D 8 4	M12 (8 pin) male connector

<b>e</b>	<b>Operating voltage</b>
1	+24 VDC (-15 / +20 %)

<b>f</b>	<b>Output</b>
S	(14) (15) (16) (17) (18) (19) = Synchronous Serial Interface
<b>Data length (box no. 14)</b>	
1	25 bit
2	24 bit
<b>Output format (box no. 15)</b>	
B	Binary
G	Gray
<b>Resolution (box no. 16)</b>	
3	0.05 mm
4	0.1 mm
5	0.02 mm
<b>Performance (box no. 17)</b>	
1	Standard
<b>Signal option (box no. 18 and 19)</b>	
0 0	Measuring direction forward

## DELIVERY



- Sensor  
Select mounting accessories regarding your application:
  - 1 or 2 rod ends M6 / 1/4"-28 UNF or / and
  - 2 mounting clamps up to 1250 mm (50 in.) stroke length, 3 mounting clamps for 1500 mm (60 in.) stroke length

Accessories have to be ordered separately.

Manuals, Software & 3D models available at:  
[www.temposonics.com](http://www.temposonics.com)

\* / Non standard stroke lengths are available; must be encoded in 5 mm / 0.1 in. increments.  
 Some preferred stroke lengths may be available with faster lead time. Contact MTS Sensors for details.

**UNITED STATES**  
**Temposonics, LLC**  
Americas & APAC Region  
3001 Sheldon Drive  
Cary, N.C. 27513  
Phone: +1 919 677-0100  
E-mail: info.us@temposonics.com

---

**GERMANY**  
**Temposonics**  
**GmbH & Co. KG**  
EMEA Region & India  
Auf dem Schüffel 9  
58513 Lüdenscheid  
Phone: +49 2351 9587-0  
E-mail: info.de@temposonics.com

---

**ITALY**  
Branch Office  
Phone: +39 030 988 3819  
E-mail: info.it@temposonics.com

---

**FRANCE**  
Branch Office  
Phone: +33 6 14 060 728  
E-mail: info.fr@temposonics.com

---

**UK**  
Branch Office  
Phone: +44 79 21 83 05 86  
E-mail: info.uk@temposonics.com

---

**SCANDINAVIA**  
Branch Office  
Phone: + 46 70 29 91 281  
E-mail: info.sca@temposonics.com

---

**CHINA**  
Branch Office  
Phone: +86 21 2415 1000 / 2415 1001  
E-mail: info.cn@temposonics.com

---

**JAPAN**  
Branch Office  
Phone: +81 3 6416 1063  
E-mail: info.jp@temposonics.com

---

**Document Part Number:**  
551342 Revision D (EN) 05/2026



**temposonics.com**