

Data Sheet

ER CANopen

Magnetostrictive Linear Position Sensors

- Compact sensor model
- Operating temperature up to +75 °C (+167 °F)
- Ideal for flexible mounting

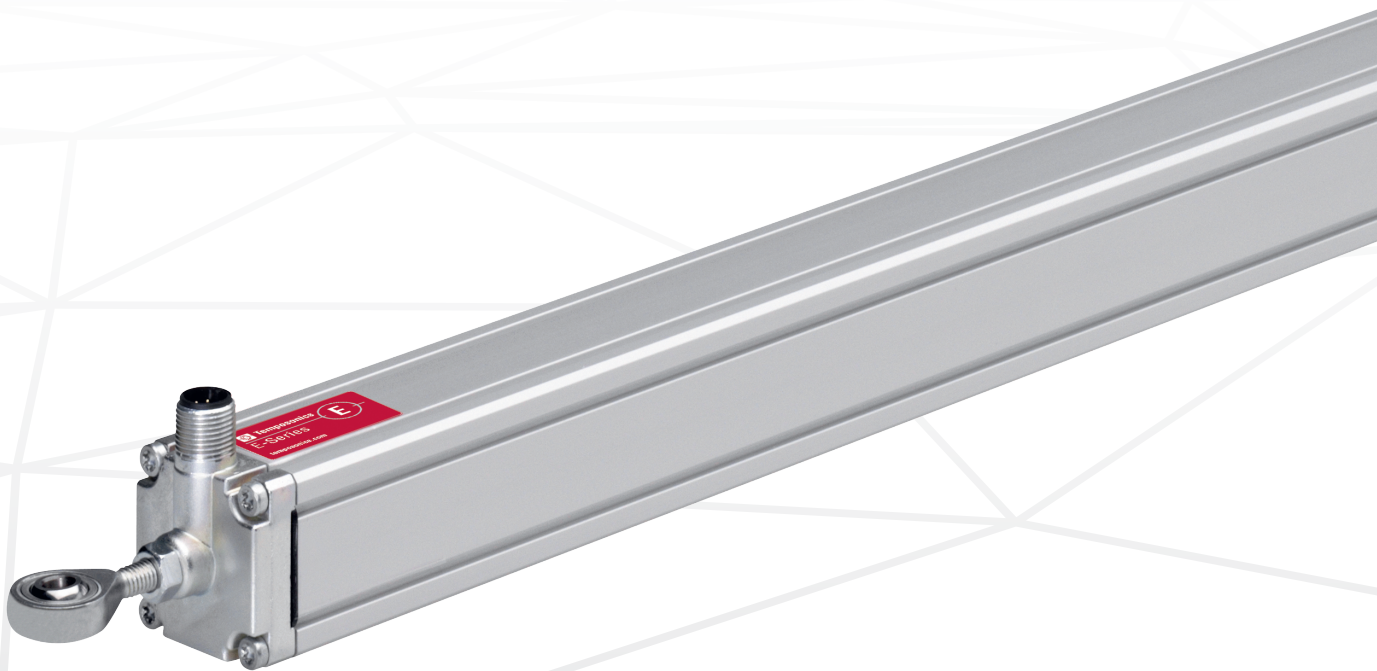

MEASURING TECHNOLOGY

The absolute, linear position sensors provided by Temposonics rely on the company's proprietary magnetostrictive technology, which can determine position with a high level of precision and robustness. Each Temposonics position sensor consists of a ferromagnetic waveguide, a position magnet, a strain pulse converter and supporting electronics. The magnet, connected to the object in motion in the application, generates a magnetic field at its location on the waveguide. A short current pulse is applied to the waveguide. This creates a momentary radial magnetic field and torsional strain on the waveguide. The momentary interaction of the magnetic fields releases a torsional strain pulse that propagates the length of the waveguide. When the ultrasonic wave reaches the end of the waveguide it is converted into an electrical signal. Since the speed of the ultrasonic wave in the waveguide is precisely known, the time required to receive the return signal can be converted into a linear position measurement with both high accuracy and repeatability.

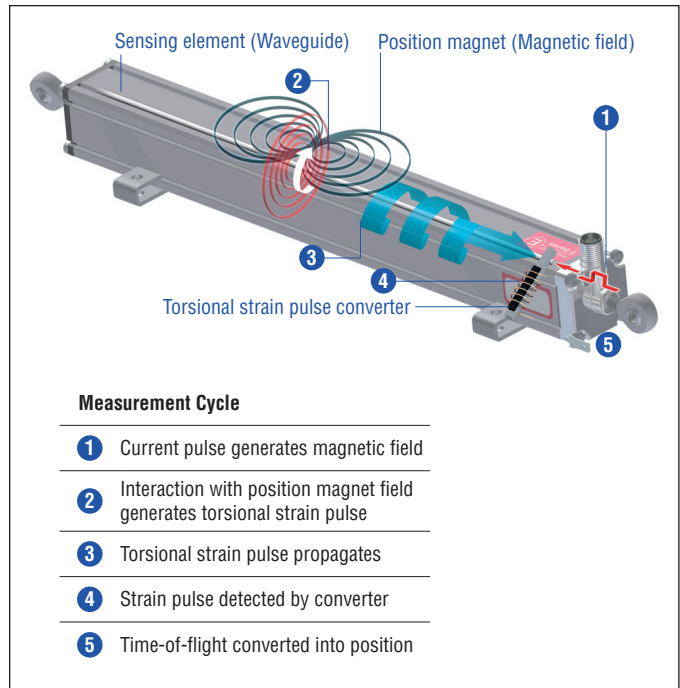

Fig. 1: Time-of-flight based magnetostrictive position sensing principle

ER SENSOR

Robust, non-contact and wear free, the Temposonics linear position sensors provide the best durability and precise position measurement feedback in harsh industrial environments. Measurement accuracy is tightly controlled by the quality of the waveguide manufactured exclusively by Temposonics.

The Temposonics® ER has an aluminum rod-and-cylinder design where the rod can extend and retract from the sensor housing to measure linear position. Inside, a magnet is secured to the end of the rod and remains protected within the sensor electronics housing. Accessory rod ends are available for attaching the rod to the machine's moving part. The rod-and-cylinder sensor design can be installed in any orientation, and provides a convenient and versatile position feedback solution. Typical fields of applications are printing and paper industry, machine tools and plastics industry as well as control systems.



Fig. 2: Typical application: Paper industry

TECHNICAL DATA

Output					
Interface	CAN System ISO 11898				
Data protocol	CANopen: CiA Standard DS 301 V3.0 / Encoder Profile DS 406 V3.1				
Baud rate, kBit/s	1000	800	500	250	125
Cable length, m	< 25	< 50	< 100	< 250	< 500
	The sensor will be supplied with ordered baud rate, changeable by customer via LSS				
Measured value	Position				
Measurement parameters					
Resolution	10 µm oder 20 µm				
Cycle time	1 ms				
Linearity	≤ ±0.02 % F.S. (minimum ±60 µm)				
Repeatability	≤ ±0.005 % F.S. (minimum ±20 µm)				
Operating conditions					
Operating temperature	-40...+75 °C (-40...+167 °F)				
Humidity	90 % relative humidity, no condensation				
Ingress protection ^{1,2}	IP67 (connectors correctly fitted)				
Shock test	100 g (single shock) IEC standard 60068-2-27				
Vibration test	5 g / 10...2000 Hz IEC standard 60068-2-6 (resonance frequencies excluded)				
EMC test	Electromagnetic emission according to EN 61000-6-3 Electromagnetic immunity according to EN 61000-6-2 The sensor meets the requirements of the EC directives and is marked with CE .				
Magnet movement velocity	≤ 5 m/s				
Design / Material					
Sensor electronics housing	Aluminum				
Guided driving rod	Aluminum				
Stroke length	50...1500 mm (2...60 in.)				
Mechanical mounting					
Mounting position	Any				
Mounting instruction	Please consult the technical drawings and the brief instructions (document number: 551774)				
Electrical connection					
Connection type	M12 (5 pin) male connector				
Operating voltage	+24 VDC (-15 / +20 %); UL recognition requires an approved power supply with energy limitation (UL 61010-1), or Class 2 rating according to the National Electrical Code (USA) / Canadian Electrical Code.				
Ripple	≤ 0.28 V _{pp}				
Current consumption	40...60 mA (depending on stroke length)				
Dielectric strength	500 VDC (DC ground to machine ground)				
Polarity protection	Up to -30 VDC				
Overvoltage protection	Up to 36 VDC				

1/ The IP rating is not part of the UL recognition.

2/ The IP rating IP67 is only valid for the sensor electronics housing, as water and dust can get inside the profile.

TECHNICAL DRAWING

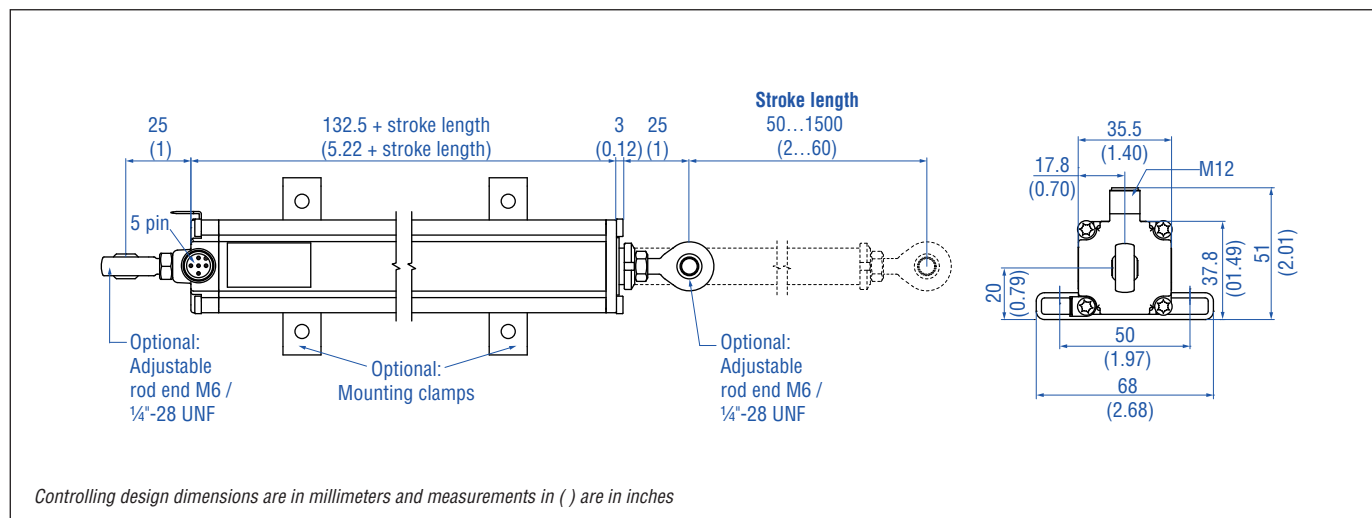



Fig. 3: Temposonics® ER

CONNECTOR WIRING

D34		
Signal + power supply		
M12 male connector (A-coded)	Pin	Function
<p>View on sensor</p>	1	Shield
	2	+24 VDC (-15 / +20 %)
	3	DC Ground (0 V)
	4	CAN_H
	5	CAN_L

Fig. 4: Connector wiring D34

FREQUENTLY ORDERED ACCESSORIES – Additional options available in our [Accessories Guide](#)  [551444](#)

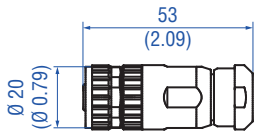
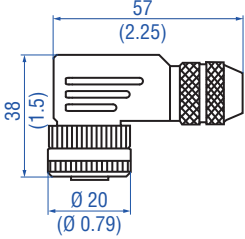
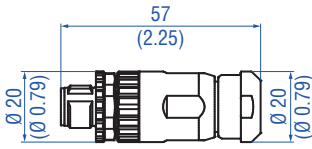
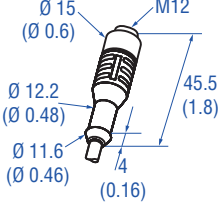
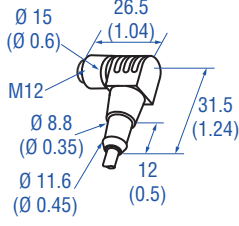
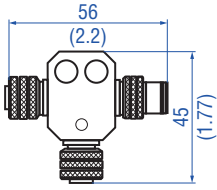
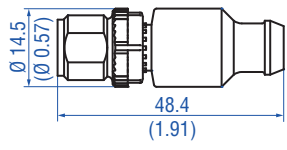
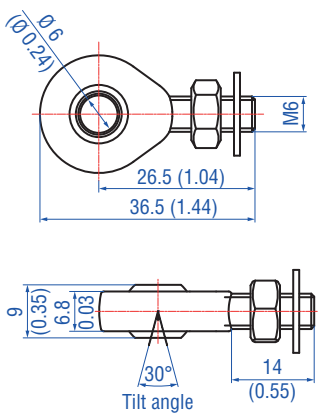
Cable connectors ³		Cord sets	
			
<p>M12 A-coded female connector (5 pin), straight Part no. 370 677</p>	<p>M12 A-coded female connector (5 pin), angled Part no. 370 678</p>	<p>M12 A-coded male connector (5 pin), straight Part no. 561 665</p>	<p>Cable with M12 A-coded female connector (5 pin), straight – pigtail Part no. 370 673</p>
<p>Material: GD-Zn, Ni Termination: Screw Contact insert: CuZn Cable Ø: 4...8 mm (0.16...0.31 in.) Wire: 1.5 mm² Operating temperature: –30...+85 °C (–22...+185 °F) Ingress protection: IP67 (correctly fitted) Fastening torque: 0.6 Nm</p>	<p>Material: GD-Zn, Ni Termination: Screw; max. 0.75 mm² Contact insert: CuZn Cable Ø: 5...8 mm (0.2...0.31 in.) Wire: 0.75 mm² (18 AWG) Operating temperature: –25...+85 °C (–13...+185 °F) Ingress protection: IP67 (correctly fitted) Fastening torque: 0.4 Nm</p>	<p>Housing: GD-Zn, Ni Termination: Screw Contact insert: CuZn Cable Ø: 4...8 mm (0.16...0.31 in.) Wire: 1.5 mm² Operating temperature: –30...+85 °C (–22...+185 °F) Ingress protection: IP67 (correctly fitted) Fastening torque: 0.6 Nm</p>	<p>Material: PUR jacket; black Features: Shielded Cable length: 5 m (16.4 ft) Ingress protection: IP67 (correctly fitted) Operating temperature: –25...+80 °C (–13...+176 °F)</p>
Mounting accessories		Mounting clamp	
			
<p>Cable with M12 A-coded female connector (5 pin), angled – pigtail Part no. 370 675</p>	<p>M12 A-coded T connector (5 pin) Part no. 370 691</p>	<p>Passive M12 A-coded male bus terminator (5 pin) Part no. 370 700</p>	<p>Rod end with M6 thread Part no. 254 210</p>
<p>Material: PUR jacket Features: Shielded Cable length: 5 m (16.4 ft) Ingress protection: IP67 (correctly fitted) Operating temperature: –25...+80 °C (–13...+176 °F)</p>	<p>Selfcuring coupling nut 2 × female connector 1 × male connector Feature: Shielded Ingress protection: IP67 (correctly fitted)</p>	<p>Material: PUR Termination: Screw Contact insert: AU Operating temperature: –25...+85 °C (–13...+121 °F) Ingress protection: IP68 (correctly fitted)</p>	<p>Material: Galvanized steel</p>

³/ Follow the manufacturer's mounting instructions

Controlling design dimensions are in millimeters and measurements in () are in inches

FREQUENTLY ORDERED ACCESSORIES – Additional options available in our [Accessories Guide](#) 551444

Rod end **Mounting clamp**

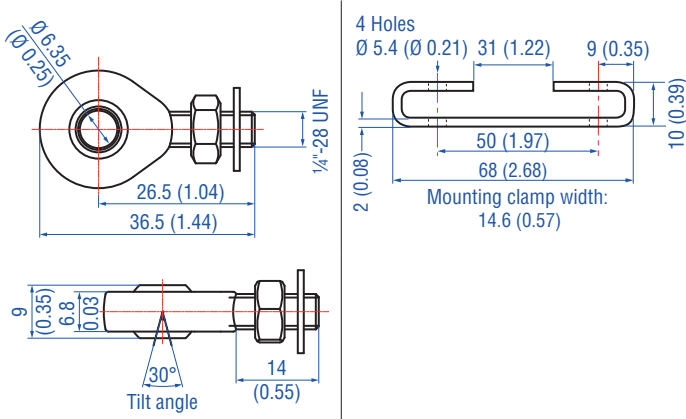

Rod end with 1/4"-28 UNF thread
Part no. 254 235

Material: Galvanized steel

Mounting clamp
Part no. 403 508

Material: Stainless steel 1.4301 / 1.4305
 (AISI 304 / 303)

ORDER CODE

1	2	3	4	5	6	7	8	9	10	11	12	13	14	15	16	17	18	19
E	R							D	3	4	1	C						1
a	b	c						d	e	f			g	h	i			

a	Sensor model
E R	Aluminum cylinder with a guided driving rod

i	Type
1	Standard

b	Design
M	Inside thread M6 at end of rod (For metric stroke length measurement)
S	Inside thread 1/4"-28 UNF at end of rod (For US customary stroke length measurement)

c	Stroke length
X X X X M	0050...1500 mm
Standard stroke length (mm)*	
50 ... 500 mm	25 mm
500...1500 mm	50 mm
X X X X U	002.0...060.0 in.
Standard stroke length (in.)*	
2...22 in.	1.0 in.
22...60 in.	2.0 in.

d	Connection type
D 3 4	M12 (5 pin) male connector

e	Operating voltage
1	+24 VDC (-15 / +20 %)

f	Output
C 3 0 4	CANopen
C 4 0 4	CANopen (bus terminator)

g	Baud rate
1	1000 kBit/s
2	500 kBit/s
3	250 kBit/s
4	125 kBit/s

h	Resolution
4	10 µm
5	20 µm

DELIVERY



- Sensor
Select mounting accessories regarding your application:
 - 1 or 2 rod ends M6 / 1/4"-28 UNF or / and
 - 2 mounting clamps up to 1250 mm (50 in.) stroke length, 3 mounting clamps for 1500 mm (60 in.) stroke length

Accessories have to be ordered separately.

Manuals, Software & 3D models available at:
www.temposonics.com

* / Non standard stroke lengths are available; must be encoded in 5 mm / 0.1 in. increments.
Some preferred stroke lengths may be available with faster lead time. Contact MTS Sensors for details.

UNITED STATES
Temposonics, LLC
Americas & APAC Region
3001 Sheldon Drive
Cary, N.C. 27513
Phone: +1 919 677-0100
E-mail: info.us@temposonics.com

GERMANY
Temposonics
GmbH & Co. KG
EMEA Region & India
Auf dem Schüffel 9
58513 Lüdenscheid
Phone: +49 2351 9587-0
E-mail: info.de@temposonics.com

ITALY
Branch Office
Phone: +39 030 988 3819
E-mail: info.it@temposonics.com

FRANCE
Branch Office
Phone: +33 6 14 060 728
E-mail: info.fr@temposonics.com

UK
Branch Office
Phone: +44 79 21 83 05 86
E-mail: info.uk@temposonics.com

SCANDINAVIA
Branch Office
Phone: + 46 70 29 91 281
E-mail: info.sca@temposonics.com

CHINA
Branch Office
Phone: +86 21 2415 1000 / 2415 1001
E-mail: info.cn@temposonics.com

JAPAN
Branch Office
Phone: +81 3 6416 1063
E-mail: info.jp@temposonics.com

Document Part Number:
551341 Revision B (EN) 05/2026



temposonics.com