

Data Sheet

E-Series ER Analog

Magnetostrictive Linear Position Sensors

- Compact sensor model
- Operating temperature up to +75 °C (+167 °F)
- Ideal for flexible mounting

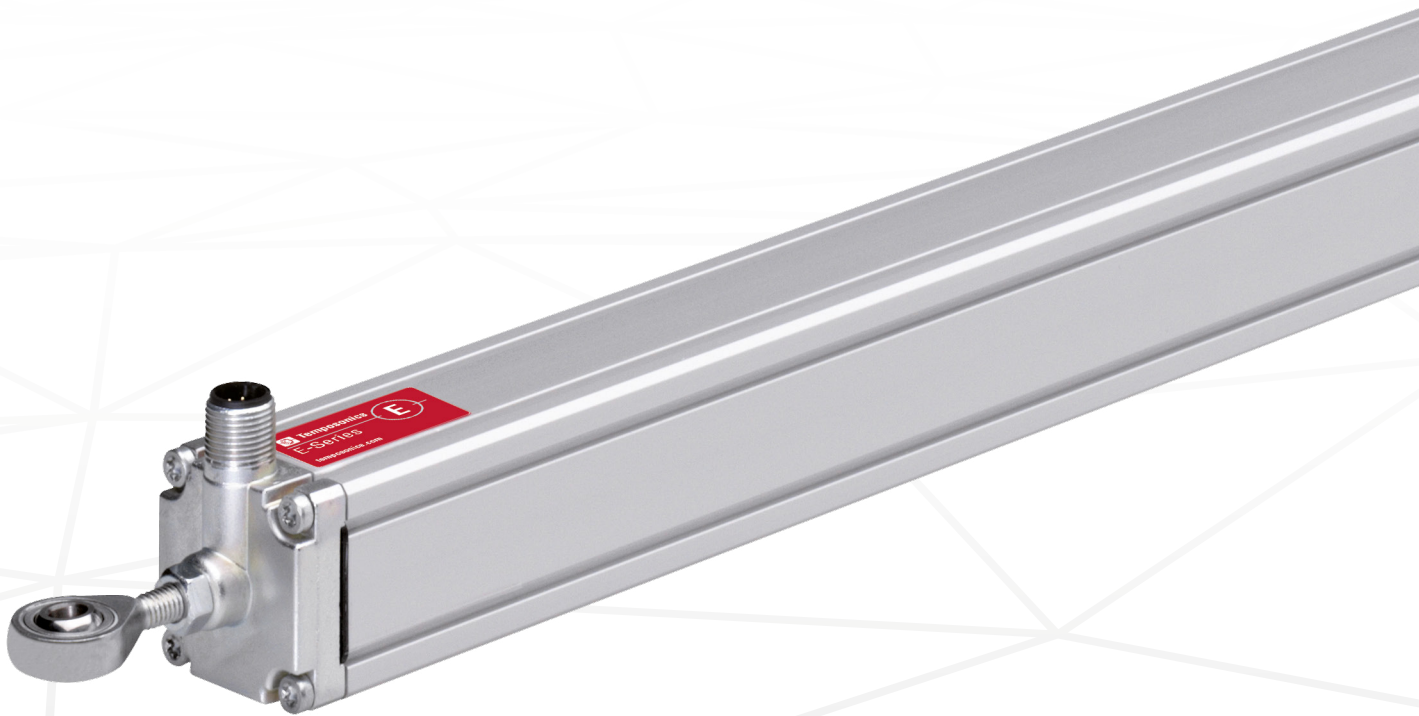

MEASURING TECHNOLOGY

The absolute, linear position sensors provided by Temposonics rely on the company's proprietary magnetostrictive technology, which can determine position with a high level of precision and robustness. Each Temposonics® position sensor consists of a ferromagnetic waveguide, a position magnet, a strain pulse converter and supporting electronics. The magnet, connected to the object in motion in the application, generates a magnetic field at its location on the waveguide. A short current pulse is applied to the waveguide. This creates a momentary radial magnetic field and torsional strain on the waveguide. The momentary interaction of the magnetic fields releases a torsional strain pulse that propagates the length of the waveguide. When the ultrasonic wave reaches the beginning of the waveguide it is converted into an electrical signal. Since the speed of the ultrasonic wave in the waveguide is precisely known, the time required to receive the return signal can be converted into a linear position measurement with both high accuracy and repeatability.

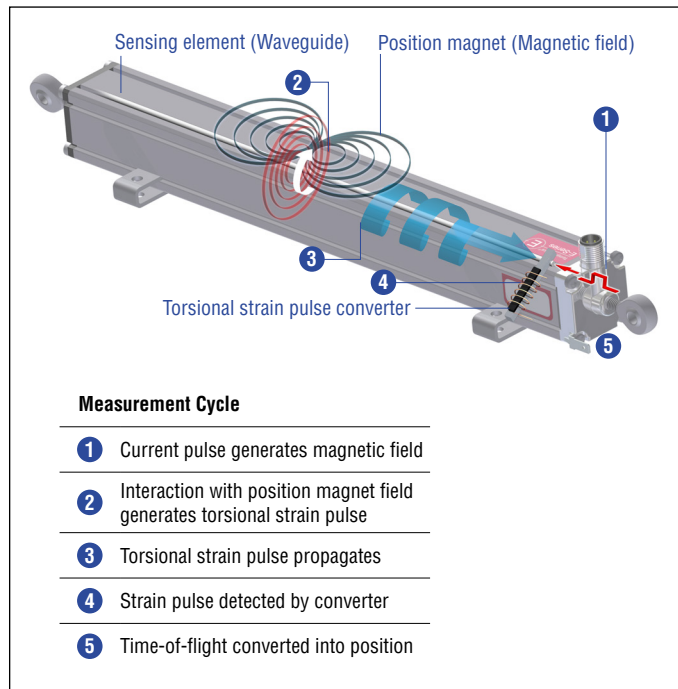

Fig. 1: Time-of-flight based magnetostrictive position sensing principle

ER SENSOR

Robust, non-contact and wear free, the Temposonics® linear position sensors provide the best durability and precise position measurement feedback in harsh industrial environments. Measurement accuracy is tightly controlled by the quality of the waveguide manufactured exclusively by Temposonics.

The Temposonics® ER has an aluminum rod-and-cylinder design where the rod can extend and retract from the sensor housing to measure linear position. Inside, a magnet is secured to the end of the rod and remains protected within the sensor electronics housing. Accessory rod ends are available for attaching the rod to the machine's moving part. The rod-and-cylinder sensor design can be installed in any orientation, and provides a convenient and versatile position feedback solution. Typical fields of applications are printing and paper industry, machine tools and plastics industry as well as control systems.



Fig. 2: Typical application: Paper industry

TECHNICAL DATA

Output	
Analog	Voltage: 0...10 VDC/10...0 VDC (controller input resistance $R_i > 5 \text{ k}\Omega$) Current: 4...20 mA/20...4 mA (minimum/maximum load: 0/500 Ω)
Measured value	Position
Measurement parameters	
Resolution	Infinite
Cycle time	Typical 0.3 ms < t < 2 ms (depending on stroke length)
Linearity deviation	$\leq \pm 0.02 \%$ F.S. (minimum $\pm 60 \mu\text{m}$)
Repeatability	$\leq \pm 0.005 \%$ F.S. (minimum $\pm 20 \mu\text{m}$)
Operating conditions	
Operating temperature	$-40...+75 \text{ }^\circ\text{C}$ ($-40...+167 \text{ }^\circ\text{F}$)
Humidity	90 % relative humidity, no condensation
Ingress protection ¹	IP67 (connectors correctly fitted)
Shock test	100 g (single shock), IEC standard 60068-2-27
Vibration test	5 g/10...2000 Hz, IEC standard 60068-2-6 (excluding resonant frequencies)
EMC test	Electromagnetic emission according to EN 61000-6-3 Electromagnetic immunity according to EN 61000-6-2 The ER sensors fulfill the requirements of the EMC directives 2014/30/EU and UKSI 2016 Nr. 1091
Magnet movement velocity	$\leq 5 \text{ m/s}$
Design/Material	
Sensor electronics housing	Aluminum
Guided driving rod	Aluminum
RoHS compliance	The used materials are compliant with the requirements of EU directive 2011/65/EU and EU regulation 2015/863 as well as UKSI 2022 No. 622 with amendments
Stroke length	50...1500 mm (2...60 in.)
Mechanical mounting	
Mounting position	Any
Mounting instruction	Please consult the technical drawing on page 4
Electrical connection	
Connection type	M12 male connector (5 pin)
Operating voltage	+24 VDC ($-15/+20 \%$); The ER sensors must be power supplied via an external Class 2 power source in accordance with the UL approval
Ripple	$\leq 0.28 \text{ V}_{pp}$
Current consumption	50...140 mA
Dielectric strength	500 VDC (DC ground to machine ground)
Polarity protection	Up to -30 VDC
Overvoltage protection	Up to 36 VDC

1/ The IP rating IP67 is only valid for the sensor electronics housing, as water and dust can get inside the profile.

TECHNICAL DRAWING

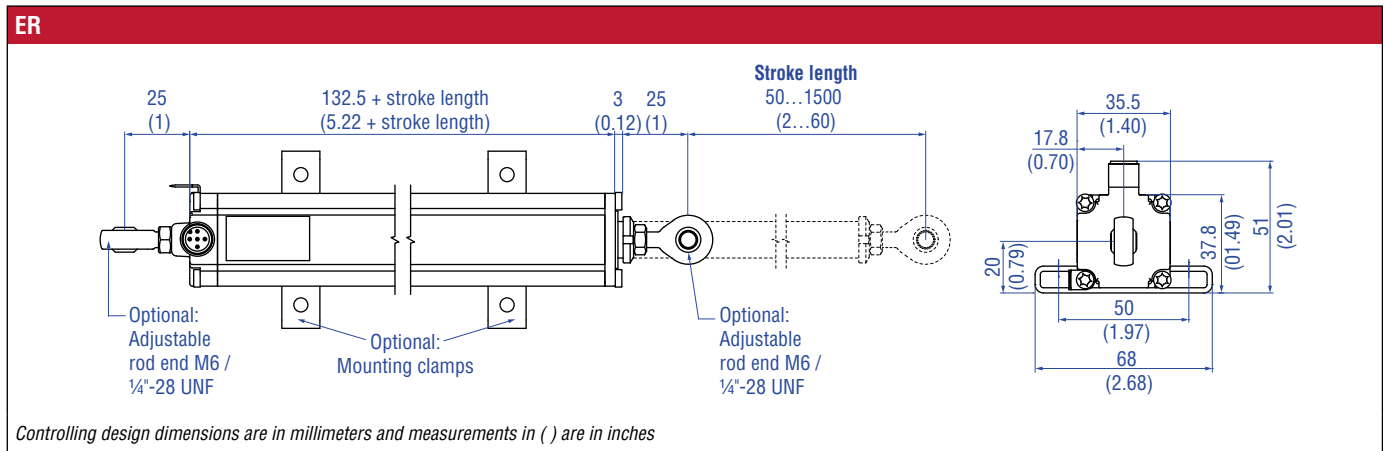

Fig. 3: Temposonics® ER

CONNECTOR WIRING

D34

Signal + power supply

M12 male connector (A-coded)	Pin	Function
<p>View on sensor</p>	1	+24 VDC (-15/+20 %)
	2	Output 1
	3	DC Ground (0 V)
	4	Output 2
	5	Signal Ground for Output 1/2

Fig. 4: Connector wiring D34

FREQUENTLY ORDERED ACCESSORIES – Additional options available in our [Accessories Catalog](#) 551444

Mounting accessories

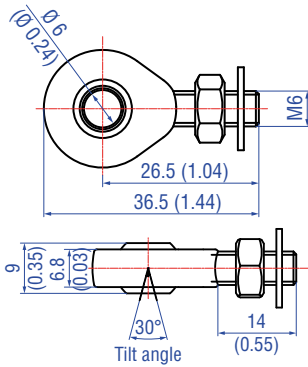

Rod end with M6 thread
Part no. 254 210

Material: Galvanized steel

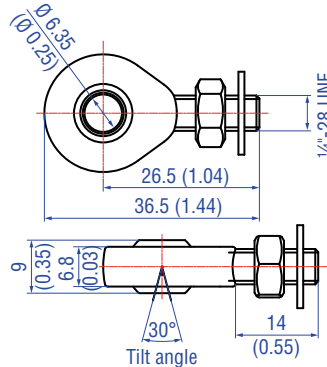

Rod end with 1/4"-28 UNF thread
Part no. 254 235

Material: Galvanized steel

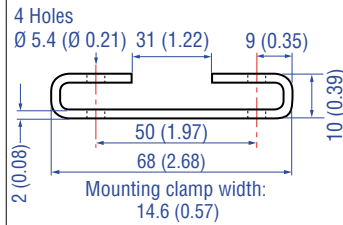

Mounting clamp
Part no. 403 508

Material: Stainless steel 1.4301/1.4305
(AISI 304/303)

Cable connectors*

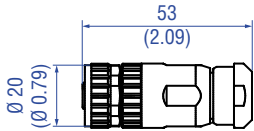

M12 A-coded female connector (4 pin/5 pin), straight
Part no. 370 677

Material: GD-Zn, Ni
Termination: Screw
Contact insert: CuZn
Cable Ø: 4...8 mm (0.16...0.31 in.)
Wire: max. 1.5 mm² (16 AWG)
Operating temperature:
-30...+85 °C (-22...+185 °F)
Ingress protection: IP67 (correctly fitted)
Fastening torque: 0.6 Nm

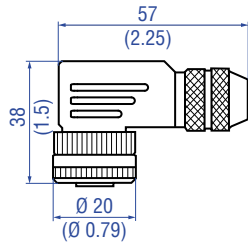

M12 A-coded female connector (5 pin), angled
Part no. 370 678

Material: GD-Zn, Ni
Termination: Screw
Contact insert: CuZn
Cable Ø: 5...8 mm (0.2...0.31 in.)
Wire: max 0.75 mm² (18 AWG)
Operating temperature:
-25...+85 °C (-13...+185 °F)
Ingress protection: IP67 (correctly fitted)
Fastening torque: 0.4 Nm

Cable sets



Cable with M12 A-coded female connector (5 pin), straight – pigtail
Part no. 370 673

Material: PUR jacket; black
Feature: Shielded
Cable length: 5 m (16.4 ft)
Ingress protection: IP67 (correctly fitted)
Operating temperature:
-25...+80 °C (-13...+176 °F)



Cable with M12 A-coded female connector (5 pin), angled – pigtail
Part no. 370 675

Material: PUR jacket; black
Feature: Shielded
Cable length: 5 m (16.4 ft)
Ingress protection: IP67 (correctly fitted)
Operating temperature:
-25...+80 °C (-13...+176 °F)

Wiring

Wires	Color	Pin	M12 A-coded female connector (5 pin)
	BN	↔ 1	
	WH	↔ 2	
	BU	↔ 3	
	BK	↔ 4	
	GY	↔ 5	

*/ Follow the manufacturer's mounting instructions
Color of connectors and cable jacket may change. Color codes for the individual wires and technical properties remain unchanged.
Controlling design dimensions are in millimeters and measurements in () are in inches

ORDER CODE

1	2	3	4	5	6	7	8	9	10	11	12	13	14	15	
E	R							D	3	4	1				
a	b	c						d	e	f					

a	Sensor model
E R	Aluminum cylinder with a guided driving rod

b	Design
M	Inside thread M6 at end of rod (For metric stroke length measurement)
S	Inside thread 1/4"-28 UNF at end of rod (For US customary stroke length measurement)

c	Stroke length
X X X X M	0050...1500 mm
Standard stroke length (mm)	
50... 500 mm	25 mm
500...1500 mm	50 mm
X X X X U	002.0...060.0 in.
Standard stroke length (in.)	
2...20 in.	1.0 in.
20...60 in.	2.0 in.
Non-standard stroke lengths are available; must be encoded in 5 mm/0.1 in. increments.	

c	Connection type
D 3 4	M12 male connector (5 pin)

d	Operating voltage
1	+24 VDC (-15/+20 %)

f	Output
Voltage	
V 0 1	0...10 VDC (1 output channel with 1 position magnet)
V 1 1	10...0 VDC (1 output channel with 1 position magnet)
V 0 3	0...10 VDC and 10...0 VDC (2 output channels with 1 position magnet)
Current	
A 0 1	4...20 mA (1 output channel with 1 position magnet)
A 1 1	20...4 mA (1 output channel with 1 position magnet)

DELIVERY



- Sensor

Accessories have to be ordered separately.

Select mounting accessories regarding your application:

- 1 or 2 rod ends
M6/1/4"-28 UNF or/and
- 2 mounting clamps up to 1250 mm (50 in.) stroke length, 3 mounting clamps for 1500 mm (60 in.) stroke length

Manuals, Software & 3D models available at:
www.temposonics.com

UNITED STATES
Temposonics, LLC
Americas & APAC Region
3001 Sheldon Drive
Cary, N.C. 27513
Phone: +1 919 677-0100
E-mail: info.us@temposonics.com

GERMANY
Temposonics
GmbH & Co. KG
EMEA Region & India
Auf dem Schüffel 9
58513 Lüdenscheid
Phone: +49 2351 9587-0
E-mail: info.de@temposonics.com

ITALY
Branch Office
Phone: +39 030 988 3819
E-mail: info.it@temposonics.com

FRANCE
Branch Office
Phone: +33 6 14 060 728
E-mail: info.fr@temposonics.com

UK
Branch Office
Phone: +44 79 21 83 05 86
E-mail: info.uk@temposonics.com

SCANDINAVIA
Branch Office
Phone: +46 70 29 91 281
E-mail: info.sca@temposonics.com

CHINA
Branch Office
Phone: +86 21 3405 7850
E-mail: info.cn@temposonics.com

JAPAN
Branch Office
Phone: +81 3 6416 1063
E-mail: info.jp@temposonics.com

Document Part number:
551246 Revision I (EN) 05/2026



temposonics.com