

Data Sheet

EP2 SSI

Magnetostrictive Linear Position Sensors

- Optimal price-/performance ratio
- Operating temperature up to +75 °C (167 °F)
- Flat & compact

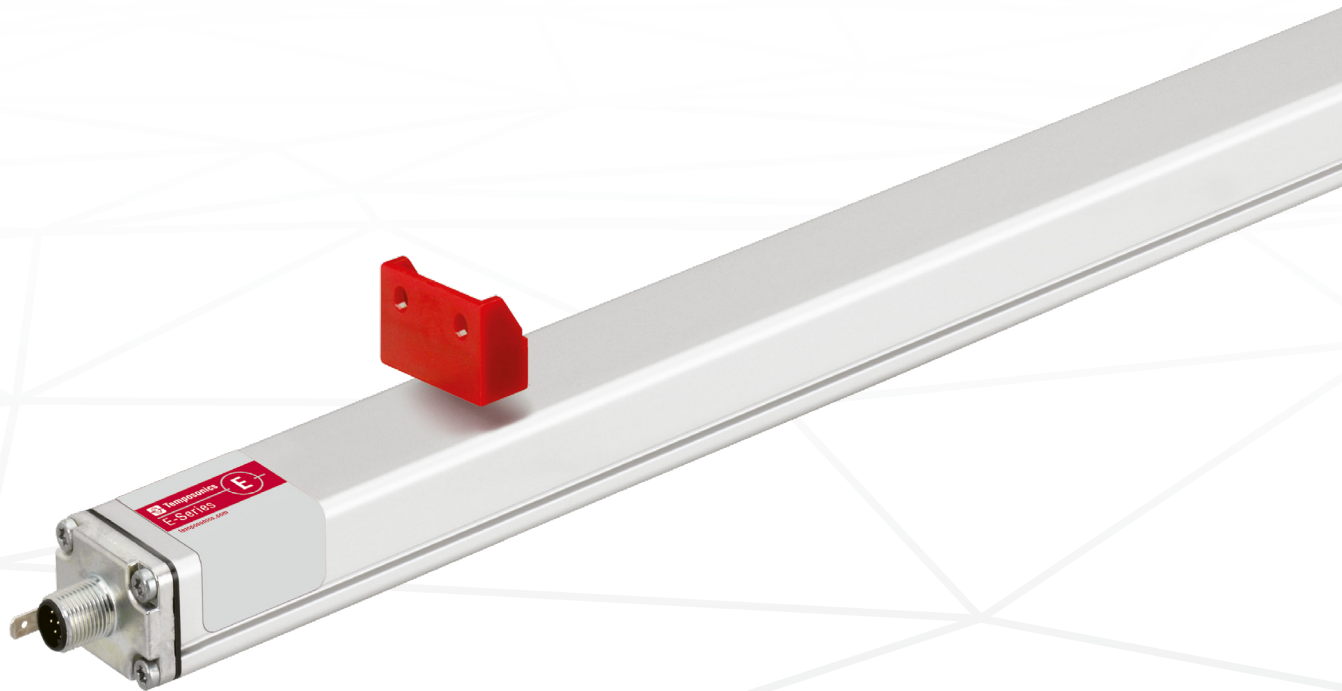

MEASURING TECHNOLOGY

The absolute, linear position sensors provided by Temposonics rely on the company's proprietary magnetostrictive technology, which can determine position with a high level of precision and robustness. Each Temposonics position sensor consists of a ferromagnetic waveguide, a position magnet, a strain pulse converter and supporting electronics. The magnet, connected to the object in motion in the application, generates a magnetic field at its location on the waveguide. A short current pulse is applied to the waveguide. This creates a momentary radial magnetic field and torsional strain on the waveguide. The momentary interaction of the magnetic fields releases a torsional strain pulse that propagates the length of the waveguide. When the ultrasonic wave reaches the end of the waveguide it is converted into an electrical signal. Since the speed of the ultrasonic wave in the waveguide is precisely known, the time required to receive the return signal can be converted into a linear position measurement with both high accuracy and repeatability.

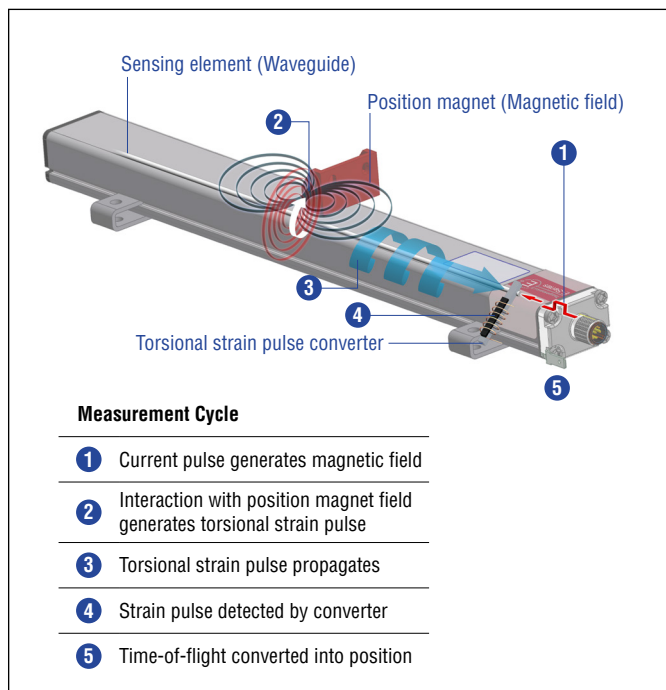

Fig. 1: Time-of-flight based magnetostrictive position sensing principle

EP2 SENSOR

Robust, non-contact and wear free, the Temposonics® linear position sensor provide high durability and precise position measurement feedback in harsh industrial environments. Measurement accuracy is tightly controlled by the quality of the waveguide manufactured exclusively by Temposonics.

The compact and flat aluminum profile offers flexible mounting options and easy installation. Moreover, the position magnet can travel along the entire flat housing profile. The EP2 has an attractive price-/performance ratio and is ideal for industrial applications including plastics molding and processing, factory automation and packaging.



Fig. 2: Plastic granulate for injection molding or extrusion

TECHNICAL DATA

Output	
Interface	SSI (Synchronous Serial Interface)
Data format	Binary or Gray
Data length	24; 25 bit
Data transmission rate	70 kBaud*...1 MBaud, dependent on cable length: Cable length < 3 m < 50 m < 100 m < 200 m < 400 m Baud rate 1.0 MBd < 400 kBd < 300 kBd < 200 kBd < 100 kBd
Measured value	Position
Measurement parameters	
Resolution	20 µm, 50 µm or 100 µm
Cycle time	Stroke length 300 mm 750 mm 1000 mm 2000 mm Measurement rate 3.7 kHz 3.0 kHz 2.3 kHz 1.2 kHz
Linearity	≤ ±0.02 % F.S. (minimum ±90 µm)
Repeatability	≤ ±0.005 % F.S. (minimum ±20 µm)
Operating conditions	
Operating temperature	-40...+75 °C (-40...+167 °F)
Humidity	90 % relative humidity, no condensation
Ingress protection ^{1,2}	IP67 (if mating cable connector is correctly fitted)
Shock test	100 g (single hit)/IEC standard 60068-2-27
Vibration test	8 g/10...2000 Hz IEC standard 60068-2-6 (resonance frequencies excluded)
EMC test	Electromagnetic emission according to EN 61000-6-3 Electromagnetic immunity according to EN 61000-6-2 The sensor meets the requirements of the EU directives and is marked with CE .
Magnet movement velocity	Any
Design/Material	
Sensor lid	Zinc die-cast
Sensor profile	Aluminum
Stroke length	50...2540 mm (2...100 in.)
Mechanical mounting	
Mounting position	Any
Mounting instruction	Please consult the technical drawings and the brief instructions (document number: 551684)
Electrical connection	
Connection typ	M12 (8 pin) male connector
Operating voltage	+24 VDC (-15/+20 %); UL recognition requires an approved power supply with energy limitation (UL 61010-1), or Class 2 rating according to the National Electrical Code (USA/ Canadian Electrical Code)
Ripple	≤ 0.28 V _{PP}
Current consumption	90 mA typical
Dielectric strength	500 VDC (DC ground to machine ground)
Polarity protection	Up to -30 VDC
Overvoltage protection	Up to 36 VDC

1/ The IP rating is not part of the UL recognition

2/ The IP rating IP67 is only valid for the sensors electronics housing, as water and dust can get inside the profile.

*/ With standard monoflop of 16 µs

TECHNICAL DRAWING

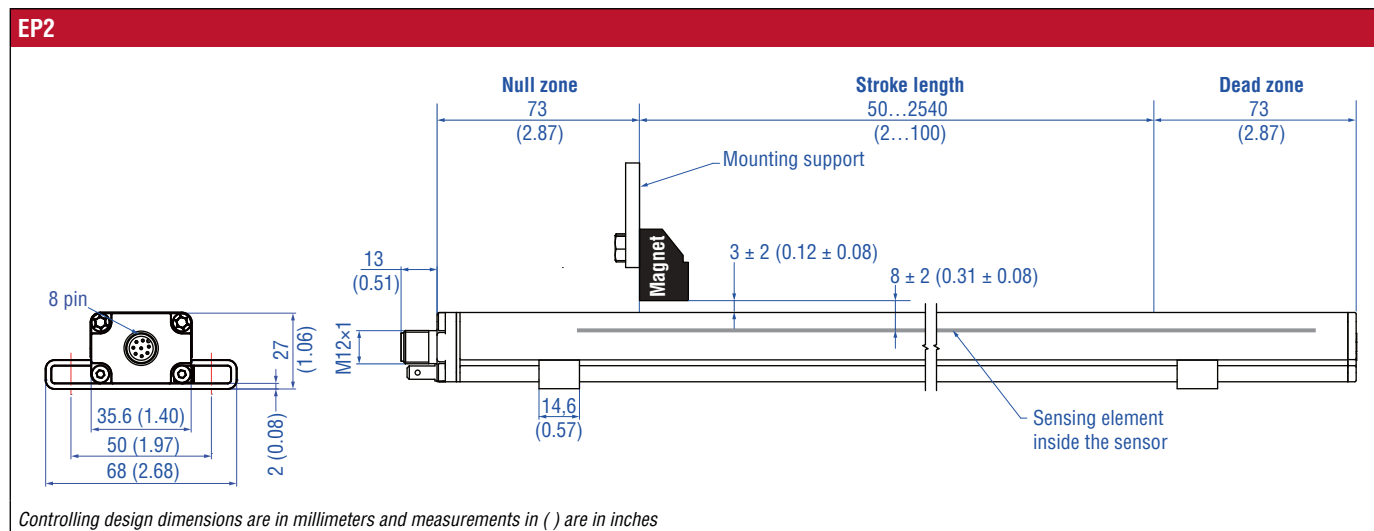

Fig. 2: E-Series EP2 with block magnet

CONNECTOR WIRING

D84

Signal + power supply

M12 male connector (A-coded)	Pin	Function
<p>View on sensor</p>	1	Clock (+)
	2	Clock (-)
	3	Data (+)
	4	Data (-)
	5	Not connected
	6	Not connected
	7	+24 VDC (-15 / +20 %)
	8	DC Ground (0 V)



Fig. 3: Connector wiring D34 (M12 connector)

FREQUENTLY ORDERED ACCESSORIES – Additional options available in our [Accessories Guide](#)  [551444](#)

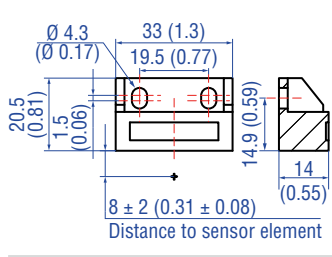
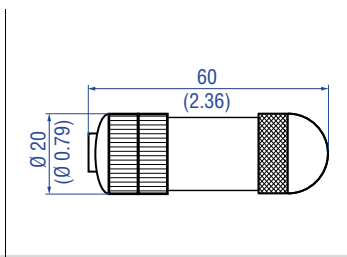
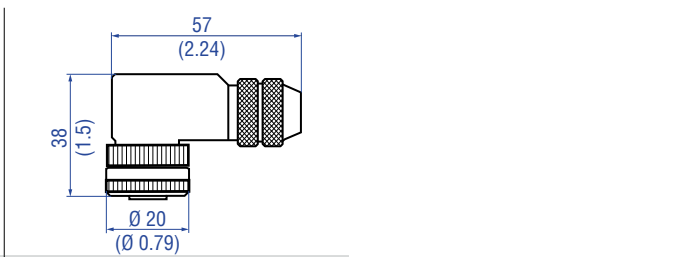
Position magnet **Cable connector***

		
<p>Block magnet L Part no. 403 448</p> <p>Material: Plastic carrier with hard ferrite magnet Weight: Approx. 20 g Fastening torque for M4 screws: 1 Nm Operating temperature: -40...+75 °C (-40...+167 °F)</p> <p>This magnet may influence the sensor performance specifications for some applications.</p>	<p>M12 A-coded female connector (8 pin), straight Part no. 370 694</p> <p>Housing: GD-ZnAL Termination: Screw Contact insert: CuZn Cable Ø: 4...9 mm (0.16...0.35 in.) Wire: 0.75 mm² Operating temperature: -25...+90 °C (-13...+194 °F) Ingress protection: IP67 (correctly fitted) Fastening torque: 0.6 Nm</p>	<p>M12 A-coded female connector (8 pin), angled Part no. 370 699</p> <p>Housing: GD-ZnAL Termination: Screw Contact insert: CuZn Cable Ø: 6...8 mm (0.24...0.31 in.) Wire: 0.5 mm² Operating temperature: -25...+85 °C (-13...+185 °F) Ingress protection: IP67 (correctly fitted) Fastening torque: 0.6 Nm</p>

Cable sets **Mounting clamp**

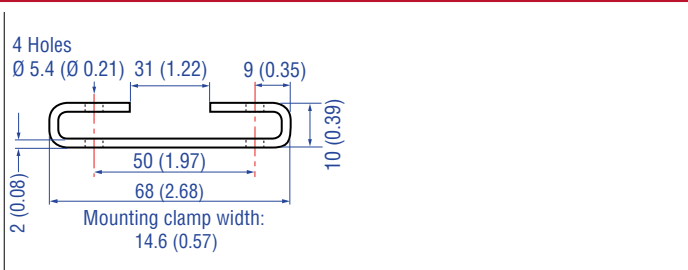
		
<p>Cable with M12 A-coded female connector (8 pin), straight – pigtail Part no. 370 674</p> <p><i>Consider cable 370 789. The additional feature “twisted pair” minimizes interference from external sources.</i></p> <p>Material: PUR jacket; black Features: Shielded Cable length: 5 m (16.4 ft) Ingress protection: IP67/IP69K (correctly fitted) Operating temperature: -25...+80 °C (-13...+176 °F)</p>	<p>Cable with M12 A-coded female connector (8 pin), angled – pigtail Part no. 370 676</p> <p><i>Consider cable 370 821. The additional feature “twisted pair” minimizes interference from external sources.</i></p> <p>Cable: Shielded Cable length: 5 m (16.4 ft) Ingress protection: IP67 (correctly fitted)</p>	<p>Mounting clamp Part no. 403 508</p> <p>Material: Stainless steel 1.4301/1.4305 (AISI 304/303)</p>

*/ Beachten Sie die Montagehinweise des Herstellers beim Anschluss der Gegenstecker
Alle Maße in mm

ORDER CODE

1	2	3	4	5	6	7	8	9	10	11	12	13	14	15	16	17	18	19
E	P	2						D	8	4	1	S						
a			b					c			d	e						

optional

a	Sensor model
E P 2	Smooth profile

b	Stroke length
X X X X M	0050...2540 mm
Standard stroke length (mm)	
50... 500 mm	25 mm
500... 2540 mm	50 mm
X X X X U	001.0...128.0 in.
Standard stroke length (in.)	
2... 20 in.	1.0 in.
20... 100 in.	2.0 in.
Non-standard stroke lengths are available; must be encoded in 5 mm/0.1 in. increments.	

c	Connection type
D 8 4	M12 (8 pin) male connector

d	Operating voltage
1	+24 VDC (-15/+20 %)

e	Output
S	(14) (15) (16) (17) (18) (19) = Synchronous Serial Interface
Data length (box no. 14)	
1	25 bit
2	24 bit
Output format (box no. 15)	
B	Binary
G	Gray
Resolution (box no. 16)	
3	0.05 mm
4	0.1 mm
5	0.02 mm
Performance (box no. 17)	
1	Standard
Optional (box no. 18 and 19)	
0 0	Measuring direction forward

DELIVERY



- Sensor
- 2 mounting clamps up to 1250 mm (50 in.) stroke length + 1 mounting clamp for each 500 mm (20 in.) additional stroke length

Accessories have to be ordered separately.

Manuals, Software & 3D Models available at:
www.temposonics.com

UNITED STATES
Temposonics, LLC
Americas & APAC Region
3001 Sheldon Drive
Cary, N.C. 27513
Phone: +1 919 677-0100
E-mail: info.us@temposonics.com

GERMANY
Temposonics
GmbH & Co. KG
EMEA Region & India
Auf dem Schüffel 9
58513 Lüdenscheid
Phone: +49 2351 9587-0
E-mail: info.de@temposonics.com

ITALY
Branch Office
Phone: +39 030 988 3819
E-mail: info.it@temposonics.com

FRANCE
Branch Office
Phone: +33 6 14 060 728
E-mail: info.fr@temposonics.com

UK
Branch Office
Phone: +44 79 21 83 05 86
E-mail: info.uk@temposonics.com

SCANDINAVIA
Branch Office
Phone: +46 70 29 91 281
E-mail: info.sca@temposonics.com

CHINA
Branch Office
Phone: +86 21 2415 1000 / 2415 1001
E-mail: info.cn@temposonics.com

JAPAN
Branch Office
Phone: +81 3 6416 1063
E-mail: info.jp@temposonics.com

Document Part Number:
551340 Revision C (EN) 05/2026



temposonics.com