

## Data Sheet

# E-Series EP2 Analog

## Magnetostrictive Linear Position Sensors

- Optimal price-/performance ratio
- Position measurement with more than one magnet
- Flat & compact

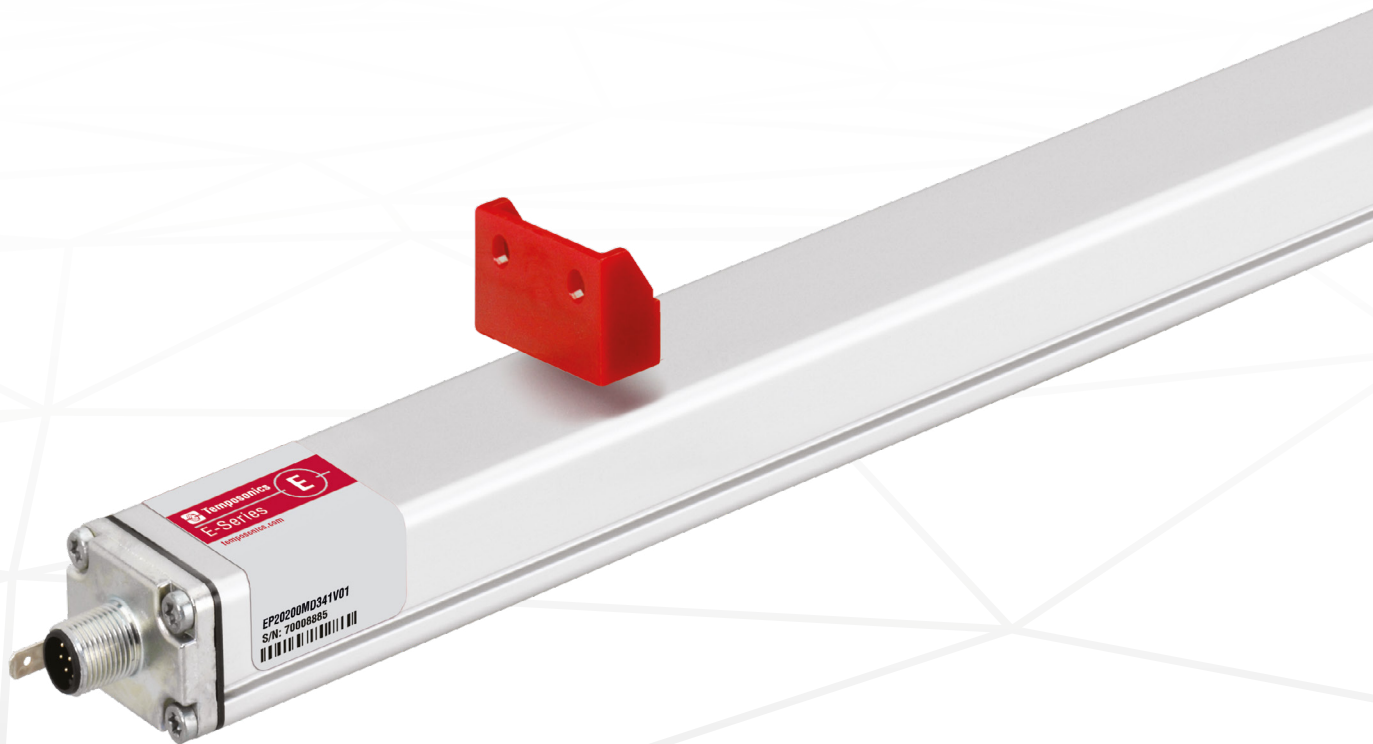

## MEASURING TECHNOLOGY

The absolute, linear position sensors provided by Temposonics rely on the company's proprietary magnetostrictive technology, which can determine position with a high level of precision and robustness. Each Temposonics® position sensor consists of a ferromagnetic waveguide, a position magnet, a strain pulse converter and supporting electronics. The magnet, connected to the object in motion in the application, generates a magnetic field at its location on the waveguide. A short current pulse is applied to the waveguide. This creates a momentary radial magnetic field and torsional strain on the waveguide. The momentary interaction of the magnetic fields releases a torsional strain pulse that propagates the length of the waveguide. When the ultrasonic wave reaches the beginning of the waveguide it is converted into an electrical signal. Since the speed of the ultrasonic wave in the waveguide is precisely known, the time required to receive the return signal can be converted into a linear position measurement with both high accuracy and repeatability.

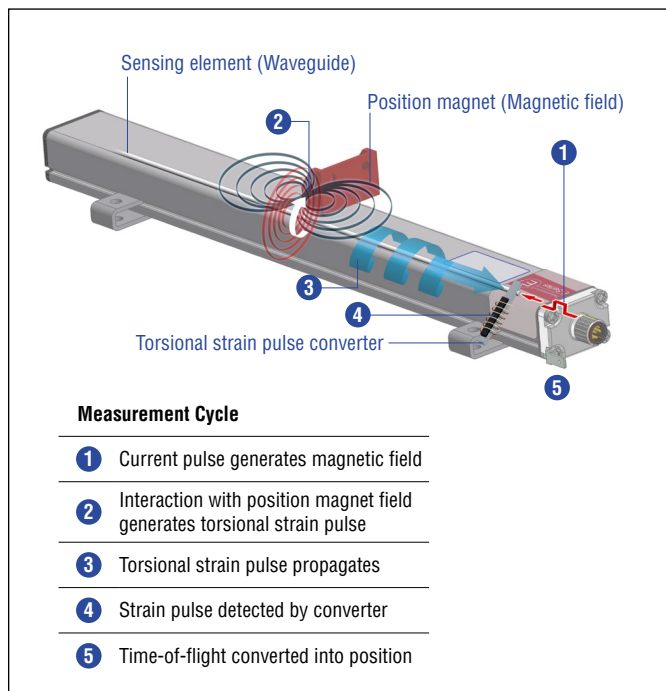

Fig. 1: Time-of-flight based magnetostrictive position sensing principle

## EP2 SENSOR

Robust, non-contact and wear free, the Temposonics® linear position sensor provide high durability and precise position measurement feedback in harsh industrial environments. Measurement accuracy is tightly controlled by the quality of the waveguide manufactured exclusively by Temposonics.

The compact and flat aluminum profile offers flexible mounting options and easy installation. Moreover, the position magnet can travel along the entire flat housing profile. The EP2 has an attractive price-/performance ratio and is ideal for industrial applications including plastics molding and processing, factory automation and packaging.



Fig. 2: Plastic granulate for injection molding or extrusion

## TECHNICAL DATA

Output	
Analog	Voltage: 0...10 VDC/10...0 VDC (controller input resistance $R_i > 5 \text{ k}\Omega$ ) Current: 4...20 mA/20...4 mA (minimum/maximum load: 0/500 $\Omega$ )
Measured value	Position/option: Multi-position measurement (2 positions)
Measurement parameters	
Resolution	Infinite
Cycle time	Typical 0.3 ms < t < 2 ms (depending on stroke length)
Linearity deviation <sup>1</sup>	$\leq \pm 0.02 \%$ F.S. (minimum $\pm 90 \mu\text{m}$ )
Repeatability	$\leq \pm 0.005 \%$ F.S. (minimum $\pm 20 \mu\text{m}$ )
Operating conditions	
Operating temperature	-40...+75 °C (-40...+167 °F)
Humidity	90 % relative humidity, no condensation
Ingress protection <sup>2</sup>	IP67 (connectors correctly fitted)
Shock test	100 g (single shock), IEC standard 60068-2-27
Vibration test	8 g/10...2000 Hz, IEC standard 60068-2-6 (excluding resonant frequencies)
EMC test	Electromagnetic emission according to EN 61000-6-3 Electromagnetic immunity according to EN 61000-6-2 The EP2 sensors fulfill the requirements of the EMC directives 2014/30/EU and UKSI 2016 No. 1091
Magnet movement velocity	Any
Design/Material	
Sensor lid	Zinc die-cast
Sensor profile	Aluminum
RoHS compliance	The used materials are compliant with the requirements of EU directive 2011/65/EU and EU regulation 2015/863 as well as UKSI 2022 No. 622 with amendments
Stroke length	50...2540 mm (2...100 in.)
Mechanical mounting	
Mounting position	Any
Mounting instruction	Please consult the technical drawing on <a href="#">page 4</a>
Electrical connection	
Connection type	M12 male connector (5 pin)
Operating voltage	+24 VDC (-15/+20 %); The EP2 sensors must be power supplied via an external Class 2 power source in accordance with the UL approval
Ripple	$\leq 0.28 \text{ V}_{PP}$
Current consumption	50...140 mA
Dielectric strength	500 VDC (DC ground to machine ground)
Polarity protection	Up to -30 VDC
Overvoltage protection	Up to 36 VDC

1/ With block magnet # 403 448

2/ The IP rating IP67 is only valid for the sensor electronics housing, as water and dust can get inside the profile.

## TECHNICAL DRAWING

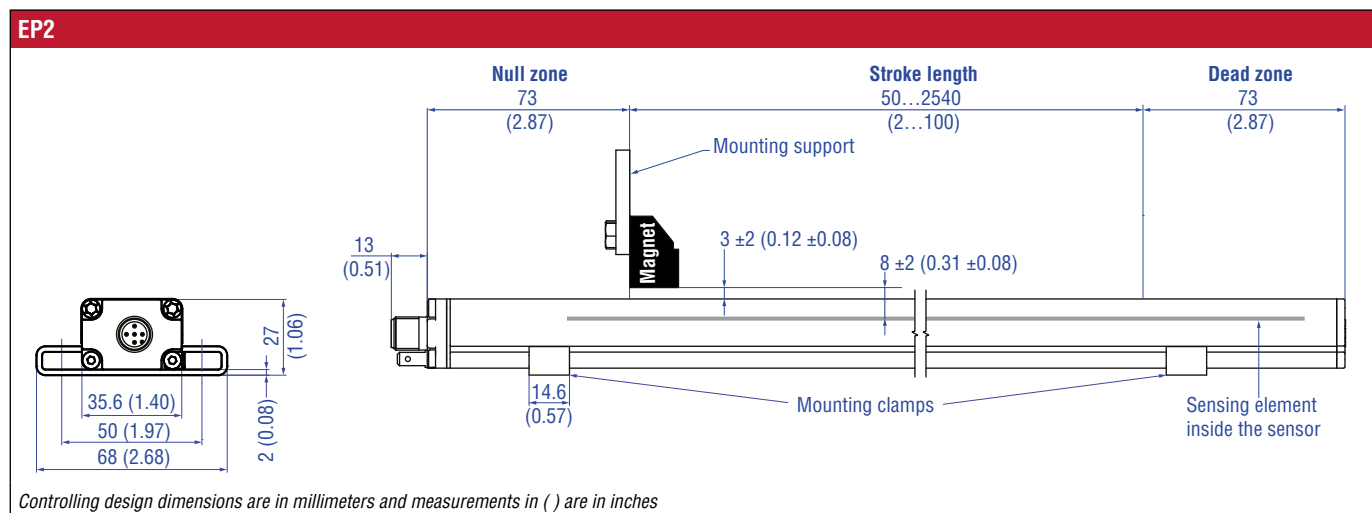

Fig. 3: Temposonics® EP2 with block magnet

## CONNECTOR WIRING

**D34**

Signal + power supply

M12 male connector (A-coded)	Pin	Function
<p>View on sensor</p>	1	+24 VDC (-15/+20 %)
	2	Output 1
	3	DC Ground (0 V)
	4	Output 2
	5	Signal Ground for Output 1/2

Fig. 4: Connector wiring D34

**FREQUENTLY ORDERED ACCESSORIES** – Additional options available in our [Accessories Catalog](#) 551444

Position magnet	Mounting accessory
<p><b>Block magnet L</b> Part no. 403 448</p>	<p><b>Mounting clamp</b> Part no. 403 508</p>
<p>Material: Plastic carrier with neodymium magnet Weight: Approx. 20 g Fastening torque for M4 screws: 1 Nm Operating temperature: -40...+75 °C (-40...+167 °F)</p> <p>This magnet may influence the sensor performance specifications for some applications.</p>	<p>Material: Stainless steel 1.4301/1.4305 (AISI 304/303)</p>

### Kabelsteckverbinder\*

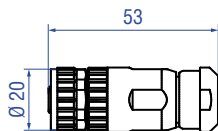

**M12-A-codierte Buchse (4 pol./5 pol.), gerade**  
Artikelnr. 370 677

Material: GD-Zn, Ni  
Anschlussart: Schraubanschluss  
Kontakteinsatz: CuZn  
Kabel Ø: 4...8 mm  
Ader: max. 1,5 mm<sup>2</sup> (16 AWG)  
Betriebstemperatur: -30...+85 °C  
Schutzart: IP67 (fachgerecht montiert)  
Anzugsmoment: 0,6 Nm

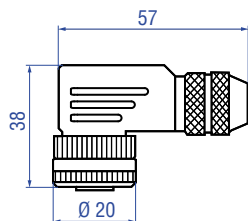

**M12-A-codierte Buchse (5 pol.), gewinkelt**  
Artikelnr. 370 678

Material: GD-Zn, Ni  
Anschlussart: Schraubanschluss  
Kontakteinsatz: CuZn  
Kabel Ø: 5...8 mm  
Ader: max 0,75 mm<sup>2</sup> (18 AWG)  
Betriebstemperatur: -25...+85 °C  
Schutzart: IP67 (fachgerecht montiert)  
Anzugsmoment: 0,4 Nm

### Kabelsets



**Kabel mit M12-A-codierter Buchse (5 pol.), gerade – offenes Kabelende**  
Artikelnr. 370 673







Material: PUR-Ummantelung; schwarz  
Eigenschaft: Geschirmt  
Kabellänge: 5 m  
Schutzart: IP67 (fachgerecht montiert)  
Betriebstemperatur: -25...+80 °C



**Kabel mit M12-A-codierter Buchse (5 pol.), gewinkelt – offenes Kabelende**  
Artikelnr. 370 675

Material: PUR-Ummantelung; schwarz  
Eigenschaft: Geschirmt  
Kabellänge: 5 m  
Schutzart: IP67 (fachgerecht montiert)  
Betriebstemperatur: -25...+80 °C

### Anschlussbelegung

Adern	Farbe	Pol.	M12-A-codierte Buchse (5 pol.)
	BN	↔ 1	
	WH	↔ 2	
	BU	↔ 3	
	BK	↔ 4	
	GY	↔ 5	

\* / Beachten Sie die Montagehinweise des Herstellers

Farbe der Stecker und Kabelmantel können sich ggf. ändern. Dabei bleiben Farben der Adern sowie technische Eigenschaften unverändert

Alle Maße in mm

## ORDER CODE

1	2	3	4	5	6	7	8	9	10	11	12	13	14	15
E	P	2						D	3	4	1			
a			b					c			d	e		

<b>a</b>	<b>Sensor model</b>													
E	P	2	Smooth profile											

<b>b</b>	<b>Stroke length</b>													
X	X	X	X	M	0050...2540 mm									

Standard stroke length (mm)	Ordering steps
50... 500 mm	25 mm
500...2540 mm	50 mm

X	X	X	X	U	002.0...100.0 in.									
---	---	---	---	---	-------------------	--	--	--	--	--	--	--	--	--

Standard stroke length (in.)	Ordering steps
2... 20 in.	1.0 in.
20...100 in.	2.0 in.

Non-standard stroke lengths are available; must be encoded in 5 mm/0.1 in. increments.

<b>c</b>	<b>Connection type</b>													
D	3	4	M12 male connector (5 pin)											

<b>d</b>	<b>Operating voltage</b>													
1	+24 VDC (-15/+20 %)													

<b>e</b>	<b>Output</b>													
----------	---------------	--	--	--	--	--	--	--	--	--	--	--	--	--

### Voltage

V	0	1	0...10 VDC (1 output channel with 1 position magnet)											
V	1	1	10...0 VDC (1 output channel with 1 position magnet)											
V	0	2	0...10 VDC (2 output channels with 2 position magnets)											
V	1	2	10...0 VDC (2 output channels with 2 position magnets)											
V	0	3	0...10 VDC and 10...0 VDC (2 output channels with 1 position magnet)											

### Current

A	0	1	4...20 mA (1 output channel with 1 position magnet)											
A	1	1	20...4 mA (1 output channel with 1 position magnet)											
A	0	2	4...20 mA (2 output channels with 2 position magnets)											
A	1	2	20...4 mA (2 output channels with 2 position magnets)											

### NOTICE

- The number of magnets is limited by the stroke length. The minimum allowed distance between magnets (i.e. front face of one to the front face of the next one) is 75 mm (3 in.)
- Use magnets of the same type for multi-position measurement.

### DELIVERY



- Sensor
  - 2 × mounting clamps up to 1250 mm (50 in.) stroke length + 1 × mounting clamps for each 500 mm (20 in.) additional stroke length
- Accessories have to be ordered separately.

Manuals, Software & 3D models available at:  
[www.temposonics.com](http://www.temposonics.com)

**UNITED STATES**  
**Temposonics, LLC**  
Americas & APAC Region  
3001 Sheldon Drive  
Cary, N.C. 27513  
Phone: +1 919 677-0100  
E-mail: [info.us@temposonics.com](mailto:info.us@temposonics.com)

---

**GERMANY**  
**Temposonics**  
**GmbH & Co. KG**  
EMEA Region & India  
Auf dem Schüffel 9  
58513 Lüdenscheid  
Phone: +49 2351 9587-0  
E-mail: [info.de@temposonics.com](mailto:info.de@temposonics.com)

---

**ITALY**  
Branch Office  
Phone: +39 030 988 3819  
E-mail: [info.it@temposonics.com](mailto:info.it@temposonics.com)

---

**FRANCE**  
Branch Office  
Phone: +33 6 14 060 728  
E-mail: [info.fr@temposonics.com](mailto:info.fr@temposonics.com)

---

**UK**  
Branch Office  
Phone: +44 79 21 83 05 86  
E-mail: [info.uk@temposonics.com](mailto:info.uk@temposonics.com)

---

**SCANDINAVIA**  
Branch Office  
Phone: +46 70 29 91 281  
E-mail: [info.sca@temposonics.com](mailto:info.sca@temposonics.com)

---

**CHINA**  
Branch Office  
Phone: +86 21 3405 7850  
E-mail: [info.cn@temposonics.com](mailto:info.cn@temposonics.com)

---

**JAPAN**  
Branch Office  
Phone: +81 3 6416 1063  
E-mail: [info.jp@temposonics.com](mailto:info.jp@temposonics.com)

---

**Document Part Number:**  
551436 Revision F (EN) 05/2026



**temposonics.com**